

E2C05

**What is the function of a DX QSL Manager?**

- A. To allocate frequencies for DXpeditions
- B. To handle the receiving and sending of confirmation cards for a DX station
- C. To run a net to allow many stations to contact a rare DX station
- D. To relay calls to and from a DX station

E2C05

**B. To handle the receiving and sending of confirmation cards for a DX station**

ARRL Extra Manual: Page 2-3

Ham Academy Lesson: 1A

Extra Class Questions valid thru 06-30-2016  
Emergency Amateur Radio Club - [www.earchi.org/education](http://www.earchi.org/education)

E2C06

**During a VHF/UHF contest, in which band segment would you expect to find the highest level of activity?**

- A. At the top of each band, usually in a segment reserved for contests
- B. In the middle of each band, usually on the national calling frequency
- C. In the weak signal segment of the band, with most of the activity near the calling frequency
- D. In the middle of the band, usually 25 kHz above the national calling frequency

E2C06

**C. In the weak signal segment of the band, with most of the activity near the calling frequency**

ARRL Extra Manual: Page 2-3

Ham Academy Lesson: 1A

Extra Class Questions valid thru 06-30-2016  
Emergency Amateur Radio Club - [www.earchi.org/education](http://www.earchi.org/education)

E2C10

**Why might a DX station state that they are listening on another frequency?**

- A. Because the DX station may be transmitting on a frequency that is prohibited to some responding stations
- B. To separate the calling stations from the DX station
- C. To reduce interference, thereby improving operating efficiency
- D. All of these choices are correct

E2C10

**D. All of these choices are correct**

ARRL Extra Manual: Page 2-5

Ham Academy Lesson: 1A

Extra Class Questions valid thru 06-30-2016  
Emergency Amateur Radio Club - [www.earchi.org/education](http://www.earchi.org/education)

E2C11

**How should you generally identify your station when attempting to contact a DX station working a pileup or in a contest?**

- A. Send your full call sign once or twice
- B. Send only the last two letters of your call sign until you make contact
- C. Send your full call sign and grid square
- D. Send the call sign of the DX station three times, the words this is, then your call sign three times

E2C11

**A. Send your full call sign once or twice**

ARRL Extra Manual: Page 2-5

Ham Academy Lesson: 1A

Extra Class Questions valid thru 06-30-2016  
Emergency Amateur Radio Club - [www.earchi.org/education](http://www.earchi.org/education)

E2C12

**What might help to restore contact when DX signals become too weak to copy across an entire HF band a few hours after sunset?**

- A. Switch to a higher frequency HF band
- B. Switch to a lower frequency HF band
- C. Wait 90 minutes or so for the signal degradation to pass
- D. Wait 24 hours before attempting another communication on the band

E2C12

**B. Switch to a lower frequency HF band**

ARRL Extra Manual: Page 2-6

Ham Academy Lesson: 1A

Extra Class Questions valid thru 06-30-2016  
Emergency Amateur Radio Club - [www.earchi.org/education](http://www.earchi.org/education)

E2C01

**Which of the following is true about contest operating?**

- A. Operators are permitted to make contacts even if they do not submit a log
- B. Interference to other amateurs is unavoidable and therefore acceptable
- C. It is mandatory to transmit the call sign of the station being worked as part of every transmission to that station
- D. Every contest requires a signal report in the exchange

E2C01

**A. Operators are permitted to make contacts even if they do not submit a log**

ARRL Extra Manual: Page 2-7

Ham Academy Lesson: 1A

Extra Class Questions valid thru 06-30-2016  
Emergency Amateur Radio Club - [www.earchi.org/education](http://www.earchi.org/education)

E2C03

**From which of the following bands is amateur radio contesting generally excluded?**

- A. 30 meters
- B. 6 meters
- C. 2 meters
- D. 33 cm

E2C03

**A. 30 meters**

ARRL Extra Manual: Page 2-7

Ham Academy Lesson: 1A

Extra Class Questions valid thru 06-30-2016  
Emergency Amateur Radio Club - [www.earchi.org/education](http://www.earchi.org/education)

E2C04

**On which of the following frequencies is an amateur radio contest contact generally discouraged?**

- A. 3.525 MHz
- B. 14.020 MHz
- C. 28.330 MHz
- D. 146.52 MHz

E2C04

**D. 146.52 MHz**

ARRL Extra Manual: Page 2-7

Ham Academy Lesson: 1A

Extra Class Questions valid thru 06-30-2016  
Emergency Amateur Radio Club - [www.earchi.org/education](http://www.earchi.org/education)

E2C07

**What is the Cabrillo format?**

- A. A standard for submission of electronic contest logs
- B. A method of exchanging information during a contest QSO
- C. The most common set of contest rules
- D. The rules of order for meetings between contest sponsors

E2C07

**A. A standard for submission of electronic contest logs**

ARRL Extra Manual: Page 2-7

Ham Academy Lesson: 1A

Extra Class Questions valid thru 06-30-2016  
Emergency Amateur Radio Club - [www.earchi.org/education](http://www.earchi.org/education)

E2C02

**Which of the following best describes the term "self-spotting" in regards to contest operating?**

- A. The generally prohibited practice of posting one's own call sign and frequency on a call sign spotting network
- B. The acceptable practice of manually posting the call signs of stations on a call sign spotting network
- C. A manual technique for rapidly zero beating or tuning to a station's frequency before calling that station
- D. An automatic method for rapidly zero beating or tuning to a station's frequency before calling that station

E2C02

**A. The generally prohibited practice of posting one's own call sign and frequency on a call sign spotting network**

ARRL Extra Manual: Page 2-9

Ham Academy Lesson: 1A

Extra Class Questions valid thru 06-30-2016  
Emergency Amateur Radio Club - [www.earchi.org/education](http://www.earchi.org/education)

E2D04

**What is the purpose of digital store-and-forward functions on an Amateur Radio satellite?**

- A. To upload operational software for the transponder
- B. To delay download of telemetry between satellites
- C. To store digital messages in the satellite for later download by other stations
- D. To relay messages between satellites

E2D04

**C. To store digital messages in the satellite for later download by other stations**

ARRL Extra Manual: Page 2-11

Ham Academy Lesson: 1A

Extra Class Questions valid thru 06-30-2016  
Emergency Amateur Radio Club - [www.earchi.org/education](http://www.earchi.org/education)

E2D05

**Which of the following techniques is normally used by low Earth orbiting digital satellites to relay messages around the world?**

- A. Digipeating
- B. Store-and-forward
- C. Multi-satellite relaying
- D. Node hopping

E2D05

**B. Store-and-forward**

ARRL Extra Manual: Page 2-11

Ham Academy Lesson: 1A

Extra Class Questions valid thru 06-30-2016  
Emergency Amateur Radio Club - [www.earchi.org/education](http://www.earchi.org/education)

E2D06

**Which of the following is a commonly used 2-meter APRS frequency?**

- A. 144.39 MHz
- B. 144.20 MHz
- C. 145.02 MHz
- D. 146.52 MHz

E2D06

**A. 144.39 MHz**

ARRL Extra Manual: Page 2-11

Ham Academy Lesson: 1A

Extra Class Questions valid thru 06-30-2016  
Emergency Amateur Radio Club - [www.earchi.org/education](http://www.earchi.org/education)

E2D07

**Which of the following digital protocols is used by APRS?**

- A. PACTOR
- B. 802.11
- C. AX.25
- D. AMTOR

E2D07

**C. AX.25**

ARRL Extra Manual: Page 2-12

Ham Academy Lesson: 1A

Extra Class Questions valid thru 06-30-2016  
Emergency Amateur Radio Club - [www.earchi.org/education](http://www.earchi.org/education)

E2D08

**Which of the following types of packet frames is used to transmit APRS beacon data?**

- A. Unnumbered Information
- B. Disconnect
- C. Acknowledgement
- D. Connect

E2D08

**A. Unnumbered Information**

ARRL Extra Manual: Page 2-12

Ham Academy Lesson: 1A

Extra Class Questions valid thru 06-30-2016  
Emergency Amateur Radio Club - [www.earchi.org/education](http://www.earchi.org/education)

E2D10

**How can an APRS station be used to help support a public service communications activity?**

- A. An APRS station with an emergency medical technician can automatically transmit medical data to the nearest hospital
- B. APRS stations with General Personnel Scanners can automatically relay the participant numbers and time as they pass the check points
- C. An APRS station with a GPS unit can automatically transmit information to show a mobile station's position during the event
- D. All of these choices are correct

E2D10

**C. An APRS station with a GPS unit can automatically transmit information to show a mobile station's position during the event**

ARRL Extra Manual: Page 2-12

Ham Academy Lesson: 1A

Extra Class Questions valid thru 06-30-2016  
Emergency Amateur Radio Club - [www.earchi.org/education](http://www.earchi.org/education)

E2D11

**Which of the following data are used by the APRS network to communicate your location?**

- A. Polar coordinates
- B. Time and frequency
- C. Radio direction finding LOPs
- D. Latitude and longitude

E2D11

**D. Latitude and longitude**

ARRL Extra Manual: Page 2-12

Ham Academy Lesson: 1A

Extra Class Questions valid thru 06-30-2016  
Emergency Amateur Radio Club - [www.earchi.org/education](http://www.earchi.org/education)

E2A03

**What is the orbital period of an Earth satellite?**

- A. The point of maximum height of a satellite's orbit
- B. The point of minimum height of a satellite's orbit
- C. The time it takes for a satellite to complete one revolution around the Earth
- D. The time it takes for a satellite to travel from perigee to apogee

E2A03

**C. The time it takes for a satellite to complete one revolution around the Earth**

ARRL Extra Manual: Page 2-13

Ham Academy Lesson: 1B

Extra Class Questions valid thru 06-30-2016  
Emergency Amateur Radio Club - [www.earchi.org/education](http://www.earchi.org/education)

E2A13

**What type of satellite appears to stay in one position in the sky?**

- A. HEO
- B. Geostationary
- C. Geomagnetic
- D. LEO

E2A13

**B. Geostationary**

ARRL Extra Manual: Page 2-13

Ham Academy Lesson: 1B

Extra Class Questions valid thru 06-30-2016  
Emergency Amateur Radio Club - [www.earchi.org/education](http://www.earchi.org/education)

E2A12

**What is one way to predict the location of a satellite at a given time?**

- A. By means of the Doppler data for the specified satellite
- B. By subtracting the mean anomaly from the orbital inclination
- C. By adding the mean anomaly to the orbital inclination
- D. By calculations using the Keplerian elements for the specified satellite

E2A12

**D. By calculations using the Keplerian elements for the specified satellite**

ARRL Extra Manual: Page 2-14

Ham Academy Lesson: 1B

Extra Class Questions valid thru 06-30-2016  
Emergency Amateur Radio Club - [www.earchi.org/education](http://www.earchi.org/education)

E2A01

**What is the direction of an ascending pass for an amateur satellite?**

- A. From west to east
- B. From east to west
- C. From south to north
- D. From north to south

E2A01

**C. From south to north**

ARRL Extra Manual: Page 2-14

Ham Academy Lesson: 1B

Extra Class Questions valid thru 06-30-2016  
Emergency Amateur Radio Club - [www.earchi.org/education](http://www.earchi.org/education)

E2A02

**What is the direction of a descending pass for an amateur satellite?**

- A. From north to south
- B. From west to east
- C. From east to west
- D. From south to north

E2A02

**A. From north to south**

ARRL Extra Manual: Page 2-14

Ham Academy Lesson: 1B

Extra Class Questions valid thru 06-30-2016  
Emergency Amateur Radio Club - [www.earchi.org/education](http://www.earchi.org/education)

E2A10

**Why may the received signal from an amateur satellite exhibit a rapidly repeating fading effect?**

- A. Because the satellite is spinning
- B. Because of ionospheric absorption
- C. Because of the satellite's low orbital altitude
- D. Because of the Doppler Effect

E2A10

**A. Because the satellite is spinning**

ARRL Extra Manual: Page 2-15

Ham Academy Lesson: 1B

Extra Class Questions valid thru 06-30-2016  
Emergency Amateur Radio Club - [www.earchi.org/education](http://www.earchi.org/education)

E2A11

**What type of antenna can be used to minimize the effects of spin modulation and Faraday rotation?**

- A. A linearly polarized antenna
- B. A circularly polarized antenna
- C. An isotropic antenna
- D. A log-periodic dipole array

E2A11

**B. A circularly polarized antenna**

ARRL Extra Manual: Page 2-15

Ham Academy Lesson: 1B

Extra Class Questions valid thru 06-30-2016  
Emergency Amateur Radio Club - [www.earchi.org/education](http://www.earchi.org/education)

E2A04

**What is meant by the term mode as applied to an amateur radio satellite?**

- A. The type of signals that can be relayed through the satellite
- B. The satellite's uplink and downlink frequency bands
- C. The satellite's orientation with respect to the Earth
- D. Whether the satellite is in a polar or equatorial orbit

E2A04

**B. The satellite's uplink and downlink frequency bands**

ARRL Extra Manual: Page 2-16

Ham Academy Lesson: 1B

Extra Class Questions valid thru 06-30-2016  
Emergency Amateur Radio Club - [www.earchi.org/education](http://www.earchi.org/education)

E2A07

**Which of the following types of signals can be relayed through a linear transponder?**

- A. FM and CW
- B. SSB and SSTV
- C. PSK and Packet
- D. All of these choices are correct

E2A07

**D. All of these choices are correct**

ARRL Extra Manual: Page 2-16

Ham Academy Lesson: 1B

Extra Class Questions valid thru 06-30-2016  
Emergency Amateur Radio Club - [www.earchi.org/education](http://www.earchi.org/education)

E2A08

**Why should effective radiated power to a satellite which uses a linear transponder be limited?**

- A. To prevent creating errors in the satellite telemetry
- B. To avoid reducing the downlink power to all other users
- C. To prevent the satellite from emitting out of band signals
- D. To avoid interfering with terrestrial QSOs

E2A08

**B. To avoid reducing the downlink power to all other users**

ARRL Extra Manual: Page 2-16

Ham Academy Lesson: 1B

Extra Class Questions valid thru 06-30-2016  
Emergency Amateur Radio Club - [www.earchi.org/education](http://www.earchi.org/education)

E2A05

**What do the letters in a satellite's mode designator specify?**

- A. Power limits for uplink and downlink transmissions
- B. The location of the ground control station
- C. The polarization of uplink and downlink signals
- D. The uplink and downlink frequency ranges

E2A05

**D. The uplink and downlink frequency ranges**

ARRL Extra Manual: Page 2-17

Ham Academy Lesson: 1B

Extra Class Questions valid thru 06-30-2016  
Emergency Amateur Radio Club - [www.earchi.org/education](http://www.earchi.org/education)

E2A06

**On what band would a satellite receive signals if it were operating in mode U/V?**

- A. 435-438 MHz
- B. 144-146 MHz
- C. 50.0-50.2 MHz
- D. 29.5 to 29.7 MHz

E2A06

**A. 435-438 MHz**

ARRL Extra Manual: Page 2-17

Ham Academy Lesson: 1B

Extra Class Questions valid thru 06-30-2016  
Emergency Amateur Radio Club - [www.earchi.org/education](http://www.earchi.org/education)

E2A09

**What do the terms L band and S band specify with regard to satellite communications?**

- A. The 23 centimeter and 13 centimeter bands
- B. The 2 meter and 70 centimeter bands
- C. FM and Digital Store-and-Forward systems
- D. Which sideband to use

E2A09

**A. The 23 centimeter and 13 centimeter bands**

ARRL Extra Manual: Page 2-17

Ham Academy Lesson: 1B

Extra Class Questions valid thru 06-30-2016  
Emergency Amateur Radio Club - [www.earchi.org/education](http://www.earchi.org/education)

E1A01 [97.301, 97.305]

**When using a transceiver that displays the carrier frequency of phone signals, which of the following displayed frequencies represents the highest frequency at which a properly adjusted USB emission will be totally within the band?**

- A. The exact upper band edge
- B. 300 Hz below the upper band edge
- C. 1 kHz below the upper band edge
- D. 3 kHz below the upper band edge

E1A01

**D. 3 kHz below the upper band edge**

ARRL Extra Manual: Page 3-4

Ham Academy Lesson: 1C

Extra Class Questions valid thru 06-30-2016  
Emergency Amateur Radio Club - [www.earchi.org/education](http://www.earchi.org/education)

E1A02 [97.301, 97.305]

**When using a transceiver that displays the carrier frequency of phone signals, which of the following displayed frequencies represents the lowest frequency at which a properly adjusted LSB emission will be totally within the band?**

- A. The exact lower band edge
- B. 300 Hz above the lower band edge
- C. 1 kHz above the lower band edge
- D. 3 kHz above the lower band edge

E1A02

**D. 3 kHz above the lower band edge**

ARRL Extra Manual: Page 3-4

Ham Academy Lesson: 1C

Extra Class Questions valid thru 06-30-2016  
Emergency Amateur Radio Club - [www.earchi.org/education](http://www.earchi.org/education)



E1A03 [97.301, 97.305]

**With your transceiver displaying the carrier frequency of phone signals, you hear a DX station's CQ on 14.349 MHz USB. Is it legal to return the call using upper sideband on the same frequency?**

- A. Yes, because the DX station initiated the contact
- B. Yes, because the displayed frequency is within the 20 meter band
- C. No, my sidebands will extend beyond the band edge
- D. No, USA stations are not permitted to use phone emissions above 14.340 MHz

E1A03

**C. No, my sidebands will extend beyond the band edge**

ARRL Extra Manual: Page 3-4

Ham Academy Lesson: 1C

Extra Class Questions valid thru 06-30-2016

Emergency Amateur Radio Club - [www.earchi.org/education](http://www.earchi.org/education)

E1A04 [97.301, 97.305]

**With your transceiver displaying the carrier frequency of phone signals, you hear a DX station calling CQ on 3.601 MHz LSB. Is it legal to return the call using lower sideband on the same frequency?**

- A. Yes, because the DX station initiated the contact
- B. Yes, because the displayed frequency is within the 75 meter phone band segment
- C. No, my sidebands will extend beyond the edge of the phone band segment
- D. No, USA stations are not permitted to use phone emissions below 3.610 MHz

E1A04

**C. No, my sidebands will extend beyond the edge of the phone band segment**

ARRL Extra Manual: Page 3-4

Ham Academy Lesson: 1C

Extra Class Questions valid thru 06-30-2016

Emergency Amateur Radio Club - [www.earchi.org/education](http://www.earchi.org/education)

E1A05 [97.313]

**What is the maximum power output permitted on the 60 meter band?**

- A. 50 watts PEP effective radiated power relative to an isotropic radiator
- B. 50 watts PEP effective radiated power relative to a dipole
- C. 100 watts PEP effective radiated power relative to the gain of a half-wave dipole
- D. 100 watts PEP effective radiated power relative to an isotropic radiator

E1A05

**C. 100 watts PEP effective radiated power relative to the gain of a half-wave dipole**

ARRL Extra Manual: Page 3-4

Ham Academy Lesson: 1C

Extra Class Questions valid thru 06-30-2016

Emergency Amateur Radio Club - [www.earchi.org/education](http://www.earchi.org/education)

E1A06 [97.303]

**Which of the following describes the rules for operation on the 60 meter band?**

- A. Working DX is not permitted
- B. Operation is restricted to specific emission types and specific channels
- C. Operation is restricted to LSB
- D. All of these choices are correct

E1A06

**B. Operation is restricted to specific emission types and specific channels**

ARRL Extra Manual: Page 3-4

Ham Academy Lesson: 1C

Extra Class Questions valid thru 06-30-2016

Emergency Amateur Radio Club - [www.earchi.org/education](http://www.earchi.org/education)

E1A07 [97.303]

**What is the only amateur band where transmission on specific channels rather than a range of frequencies is permitted?**

- A. 12 meter band
- B. 17 meter band
- C. 30 meter band
- D. 60 meter band

E1A07

**D. 60 meter band**

ARRL Extra Manual: Page 3-4

Ham Academy Lesson: 1C

Extra Class Questions valid thru 06-30-2016  
Emergency Amateur Radio Club - [www.earchi.org/education](http://www.earchi.org/education)

E1A12 [97.301, 97.305]

**With your transceiver displaying the carrier frequency of CW signals, you hear a DX station's CQ on 3.500 MHz. Is it legal to return the call using CW on the same frequency?**

- A. Yes, the DX station initiated the contact
- B. Yes, the displayed frequency is within the 80 meter CW band segment
- C. No, sidebands from the CW signal will be out of the band.
- D. No, USA stations are not permitted to use CW emissions below 3.525 MHz

E1A12

**C. No, sidebands from the CW signal will be out of the band.**

ARRL Extra Manual: Page 3-4

Ham Academy Lesson: 1C

Extra Class Questions valid thru 06-30-2016  
Emergency Amateur Radio Club - [www.earchi.org/education](http://www.earchi.org/education)

E1B05 [97.303]

**What is the maximum bandwidth for a data emission on 60 meters?**

- A. 60 Hz
- B. 170 Hz
- C. 1.5 kHz
- D. 2.8 kHz

E1B05

**D. 2.8 kHz**

ARRL Extra Manual: Page 3-4

Ham Academy Lesson: 1C

Extra Class Questions valid thru 06-30-2016  
Emergency Amateur Radio Club - [www.earchi.org/education](http://www.earchi.org/education)

E1B07 [97.15]

**Where must the carrier frequency of a CW signal be set to comply with FCC rules for 60 meter operation?**

- A. At the lowest frequency of the channel
- B. At the center frequency of the channel
- C. At the highest frequency of the channel
- D. On any frequency where the signal's sidebands are within the channel

E1B07

**B. At the center frequency of the channel**

ARRL Extra Manual: Page 3-4

Ham Academy Lesson: 1C

Extra Class Questions valid thru 06-30-2016  
Emergency Amateur Radio Club - [www.earchi.org/education](http://www.earchi.org/education)

E1A08 [97.219]

**If a station in a message forwarding system inadvertently forwards a message that is in violation of FCC rules, who is primarily accountable for the rules violation?**

- A. The control operator of the packet bulletin board station
- B. The control operator of the originating station
- C. The control operators of all the stations in the system
- D. The control operators of all the stations in the system not authenticating the source from which they accept communications

E1A08

**B. The control operator of the originating station**

ARRL Extra Manual: Page 3-6

Ham Academy Lesson: 1C

Extra Class Questions valid thru 06-30-2016

Emergency Amateur Radio Club - [www.earchi.org/education](http://www.earchi.org/education)

E1A09 [97.219]

**What is the first action you should take if your digital message forwarding station inadvertently forwards a communication that violates FCC rules?**

- A. Discontinue forwarding the communication as soon as you become aware of it
- B. Notify the originating station that the communication does not comply with FCC rules
- C. Notify the nearest FCC Field Engineer's office
- D. Discontinue forwarding all messages

E1A09

**A. Discontinue forwarding the communication as soon as you become aware of it**

ARRL Extra Manual: Page 3-6

Ham Academy Lesson: 1C

Extra Class Questions valid thru 06-30-2016

Emergency Amateur Radio Club - [www.earchi.org/education](http://www.earchi.org/education)

E1B09 [97.407]

**Which amateur stations may be operated in RACES?**

- A. Only those club stations licensed to Amateur Extra class operators
- B. Any FCC-licensed amateur station except a Technician class operator's station
- C. Any FCC-licensed amateur station certified by the responsible civil defense organization for the area served
- D. Any FCC-licensed amateur station participating in the Military Affiliate Radio System (MARS)

E1B09

**C. Any FCC-licensed amateur station certified by the responsible civil defense organization for the area served**

ARRL Extra Manual: Page 3-6

Ham Academy Lesson: 1C

Extra Class Questions valid thru 06-30-2016

Emergency Amateur Radio Club - [www.earchi.org/education](http://www.earchi.org/education)

E1B10 [97.407]

**What frequencies are authorized to an amateur station participating in RACES?**

- A. All amateur service frequencies authorized to the control operator
- B. Specific segments in the amateur service MF, HF, VHF and UHF bands
- C. Specific local government channels
- D. Military Affiliate Radio System (MARS) channels

E1B10

**A. All amateur service frequencies authorized to the control operator**

ARRL Extra Manual: Page 3-6

Ham Academy Lesson: 1C

Extra Class Questions valid thru 06-30-2016

Emergency Amateur Radio Club - [www.earchi.org/education](http://www.earchi.org/education)

E1A10 [97.11]

**If an amateur station is installed aboard a ship or aircraft, what condition must be met before the station is operated?**

- A. Its operation must be approved by the master of the ship or the pilot in command of the aircraft
- B. The amateur station operator must agree to not transmit when the main ship or aircraft radios are in use
- C. It must have a power supply that is completely independent of the main ship or aircraft power supply
- D. Its operator must have an FCC Marine or Aircraft endorsement on his or her amateur license

E1A10

**A. Its operation must be approved by the master of the ship or the pilot in command of the aircraft**

ARRL Extra Manual: Page 3-7

Ham Academy Lesson: 1C

Extra Class Questions valid thru 06-30-2016

Emergency Amateur Radio Club - [www.earchi.org/education](http://www.earchi.org/education)

E1A11 [97.5]

**What authorization or licensing is required when operating an amateur station aboard a US-registered vessel in international waters?**

- A. Any amateur license with an FCC Marine or Aircraft endorsement
- B. Any FCC-issued amateur license or a reciprocal permit for an alien amateur licensee
- C. Only General class or higher amateur licenses
- D. An unrestricted Radiotelephone Operator Permit

E1A11

**B. Any FCC-issued amateur license or a reciprocal permit for an alien amateur licensee**

ARRL Extra Manual: Page 3-7

Ham Academy Lesson: 1C

Extra Class Questions valid thru 06-30-2016

Emergency Amateur Radio Club - [www.earchi.org/education](http://www.earchi.org/education)

E1A13 [97.5]

**Who must be in physical control of the station apparatus of an amateur station aboard any vessel or craft that is documented or registered in the United States?**

- A. Only a person with an FCC Marine Radio
- B. Any person holding an FCC-issued amateur license or who is authorized for alien reciprocal operation
- C. Only a person named in an amateur station license grant
- D. Any person named in an amateur station license grant or a person holding an unrestricted Radiotelephone Operator Permit

E1A13

**B. Any person holding an FCC-issued amateur license or who is authorized for alien reciprocal operation**

ARRL Extra Manual: Page 3-7

Ham Academy Lesson: 1C

Extra Class Questions valid thru 06-30-2016

Emergency Amateur Radio Club - [www.earchi.org/education](http://www.earchi.org/education)

E1B01 [97.3]

**Which of the following constitutes a spurious emission?**

- A. An amateur station transmission made at random without the proper call sign identification
- B. A signal transmitted to prevent its detection by any station other than the intended recipient
- C. Any transmitted bogus signal that interferes with another licensed radio station
- D. An emission outside its necessary bandwidth that can be reduced or eliminated without affecting the information transmitted

E1B01

**D. An emission outside its necessary bandwidth that can be reduced or eliminated without affecting the information transmitted**

ARRL Extra Manual: Page 3-8

Ham Academy Lesson: 1D

Extra Class Questions valid thru 06-30-2016

Emergency Amateur Radio Club - [www.earchi.org/education](http://www.earchi.org/education)

E1B02 [97.13]

**Which of the following factors might cause the physical location of an amateur station apparatus or antenna structure to be restricted?**

- A. The location is near an area of political conflict
- B. The location is of geographical or horticultural importance
- C. The location is in an ITU zone designated for coordination with one or more foreign governments
- D. The location is of environmental importance or significant in American history, architecture, or culture

E1B02

**D. The location is of environmental importance or significant in American history, architecture, or culture**

ARRL Extra Manual: Page 3-8

Ham Academy Lesson: 1D

Extra Class Questions valid thru 06-30-2016

Emergency Amateur Radio Club - [www.earchi.org/education](http://www.earchi.org/education)

E1B03 [97.13]

**Within what distance must an amateur station protect an FCC monitoring facility from harmful interference?**

- A. 1 mile
- B. 3 miles
- C. 10 miles
- D. 30 miles

E1B03

**A. 1 mile**

ARRL Extra Manual: Page 3-8

Ham Academy Lesson: 1D

Extra Class Questions valid thru 06-30-2016

Emergency Amateur Radio Club - [www.earchi.org/education](http://www.earchi.org/education)

E1B04 [97.13, 1.1305-1.1319]

**What must be done before placing an amateur station within an officially designated wilderness area or wildlife preserve, or an area listed in the National Register of Historical Places?**

- A. A proposal must be submitted to the National Park Service
- B. A letter of intent must be filed with the National Audubon Society
- C. An Environmental Assessment must be submitted to the FCC
- D. A form FSD-15 must be submitted to the Department of the Interior

E1B04

**C. An Environmental Assessment must be submitted to the FCC**

ARRL Extra Manual: Page 3-8

Ham Academy Lesson: 1D

Extra Class Questions valid thru 06-30-2016

Emergency Amateur Radio Club - [www.earchi.org/education](http://www.earchi.org/education)

E1B08 [97.121]

**What limitations may the FCC place on an amateur station if its signal causes interference to domestic broadcast reception, assuming that the receiver(s) involved are of good engineering design?**

- A. The amateur station must cease operation
- B. The amateur station must cease operation on all frequencies below 30 MHz
- C. The amateur station must cease operation on all frequencies above 30 MHz
- D. The amateur station must avoid transmitting during certain hours on frequencies that cause the interference

E1B08

**D. The amateur station must avoid transmitting during certain hours on frequencies that cause the interference**

ARRL Extra Manual: Page 3-8

Ham Academy Lesson: 1D

Extra Class Questions valid thru 06-30-2016

Emergency Amateur Radio Club - [www.earchi.org/education](http://www.earchi.org/education)

E1B11 [97.307]

**What is the permitted mean power of any spurious emission relative to the mean power of the fundamental emission from a station transmitter or external RF amplifier installed after January 1, 2003, and transmitting on a frequency below 30 MHZ?**

- A. At least 43 dB below
- B. At least 53 dB below
- C. At least 63 dB below
- D. At least 73 dB below

E1B11

**A. At least 43 dB below**

ARRL Extra Manual: Page 3-8

Ham Academy Lesson: 1D

Extra Class Questions valid thru 06-30-2016

Emergency Amateur Radio Club - [www.earchi.org/education](http://www.earchi.org/education)

E1B06 [97.15]

**Which of the following additional rules apply if you are installing an amateur station antenna at a site at or near a public use airport?**

- A. You may have to notify the Federal Aviation Administration and register it with the FCC as required by Part 17 of FCC rules
- B. No special rules apply if your antenna structure will be less than 300 feet in height
- C. You must file an Environmental Impact Statement with the EPA before construction begins
- D. You must obtain a construction permit from the airport zoning authority

E1B06

**A. You may have to notify the Federal Aviation Administration and register it with the FCC as required by Part 17 of FCC rules**

ARRL Extra Manual: Page 3-9

Ham Academy Lesson: 1D

Extra Class Questions valid thru 06-30-2016

Emergency Amateur Radio Club - [www.earchi.org/education](http://www.earchi.org/education)

E1C01 [97.3]

**What is a remotely controlled station?**

- A. A station operated away from its regular home location
- B. A station controlled by someone other than the licensee
- C. A station operating under automatic control
- D. A station controlled indirectly through a control link

E1C01

**D. A station controlled indirectly through a control link**

ARRL Extra Manual: Page 3-10

Ham Academy Lesson: 1D

Extra Class Questions valid thru 06-30-2016

Emergency Amateur Radio Club - [www.earchi.org/education](http://www.earchi.org/education)

E1C06 [97.109]

**Which of the following statements concerning remotely controlled amateur stations is true?**

- A. Only Extra Class operators may be the control operator of a remote station
- B. A control operator need not be present at the control point
- C. A control operator must be present at the control point
- D. Repeater and auxiliary stations may not be remotely controlled

E1C06

**C. A control operator must be present at the control point**

ARRL Extra Manual: Page 3-10

Ham Academy Lesson: 1D

Extra Class Questions valid thru 06-30-2016

Emergency Amateur Radio Club - [www.earchi.org/education](http://www.earchi.org/education)

E1C07 [97.3]

**What is meant by local control?**

- A. Controlling a station through a local auxiliary link
- B. Automatically manipulating local station controls
- C. Direct manipulation of the transmitter by a control operator
- D. Controlling a repeater using a portable handheld transceiver

E1C07

**C. Direct manipulation of the transmitter by a control operator**

ARRL Extra Manual: Page 3-10

Ham Academy Lesson: 1D

Extra Class Questions valid thru 06-30-2016

Emergency Amateur Radio Club - [www.earchi.org/education](http://www.earchi.org/education)

E1C08 [97.213]

**What is the maximum permissible duration of a remotely controlled station's transmissions if its control link malfunctions?**

- A. 30 seconds
- B. 3 minutes
- C. 5 minutes
- D. 10 minutes

E1C08

**B. 3 minutes**

ARRL Extra Manual: Page 3-10

Ham Academy Lesson: 1D

Extra Class Questions valid thru 06-30-2016

Emergency Amateur Radio Club - [www.earchi.org/education](http://www.earchi.org/education)

E1C02 [97.3, 97.109]

**What is meant by automatic control of a station?**

- A. The use of devices and procedures for control so that the control operator does not have to be present at a control point
- B. A station operating with its output power controlled automatically
- C. Remotely controlling a station's antenna pattern through a directional control link
- D. The use of a control link between a control point and a locally controlled station

E1C02

**A. The use of devices and procedures for control so that the control operator does not have to be present at a control point**

ARRL Extra Manual: Page 3-12

Ham Academy Lesson: 1D

Extra Class Questions valid thru 06-30-2016

Emergency Amateur Radio Club - [www.earchi.org/education](http://www.earchi.org/education)

E1C03 [97.3, 97.109]

**How do the control operator responsibilities of a station under automatic control differ from one under local control?**

- A. Under local control there is no control operator
- B. Under automatic control the control operator is not required to be present at the control point
- C. Under automatic control there is no control operator
- D. Under local control a control operator is not required to be present at a control point

E1C03

**B. Under automatic control the control operator is not required to be present at the control point**

ARRL Extra Manual: Page 3-12

Ham Academy Lesson: 1D

Extra Class Questions valid thru 06-30-2016

Emergency Amateur Radio Club - [www.earchi.org/education](http://www.earchi.org/education)

E1C04 [97.109]

**When may an automatically controlled station retransmit third party communications?**

- A. Never
- B. Only when transmitting RTTY or data emissions
- C. When specifically agreed upon by the sending and receiving stations
- D. When approved by the National Telecommunication and Information Administration

E1C04

**B. Only when transmitting RTTY or data emissions**

ARRL Extra Manual: Page 3-12

Ham Academy Lesson: 1D

Extra Class Questions valid thru 06-30-2016  
Emergency Amateur Radio Club - [www.earchi.org/education](http://www.earchi.org/education)

E1C05 [97.109]

**When may an automatically controlled station originate third party communications?**

- A. Never
- B. Only when transmitting an RTTY or data emissions
- C. When specifically agreed upon by the sending and receiving stations
- D. When approved by the National Telecommunication and Information Administration

E1C05

**A. Never**

ARRL Extra Manual: Page 3-12

Ham Academy Lesson: 1D

Extra Class Questions valid thru 06-30-2016  
Emergency Amateur Radio Club - [www.earchi.org/education](http://www.earchi.org/education)

E1C09 [97.205]

**Which of these frequencies are available for an automatically controlled repeater operating below 30 MHz?**

- A. 18.110 - 18.168 MHz
- B. 24.940 - 24.990 MHz
- C. 10.100 - 10.150 MHz
- D. 29.500 - 29.700 MHz

E1C09

**D. 29.500 - 29.700 MHz**

ARRL Extra Manual: Page 3-12

Ham Academy Lesson: 1D

Extra Class Questions valid thru 06-30-2016  
Emergency Amateur Radio Club - [www.earchi.org/education](http://www.earchi.org/education)

E1C10 [97.113(d)]

**What types of amateur stations may automatically retransmit the radio signals of other amateur stations?**

- A. Only beacon, repeater or space stations
- B. Only auxiliary, repeater or space stations
- C. Only earth stations, repeater stations or model craft
- D. Only auxiliary, beacon or space stations

E1C10

**B. Only auxiliary, repeater or space stations**

ARRL Extra Manual: Page 3-12

Ham Academy Lesson: 1D

Extra Class Questions valid thru 06-30-2016  
Emergency Amateur Radio Club - [www.earchi.org/education](http://www.earchi.org/education)



E1D02 [97.3]

**What is the amateur satellite service?**

- A. A radio navigation service using satellites for the purpose of self training, intercommunication and technical studies carried out by amateurs
- B. A spacecraft launching service for amateur-built satellites
- C. A radio communications service using amateur radio stations on satellites
- D. A radio communications service using stations on Earth satellites for public service broadcast

E1D02

**C. A radio communications service using amateur radio stations on satellites**

ARRL Extra Manual: Page 3-12

Ham Academy Lesson: 1D

Extra Class Questions valid thru 06-30-2016  
Emergency Amateur Radio Club - [www.earchi.org/education](http://www.earchi.org/education)

E1D04 [97.3]

**What is an Earth station in the amateur satellite service?**

- A. An amateur station within 50 km of the Earth's surface intended for communications with amateur stations by means of objects in space
- B. An amateur station that is not able to communicate using amateur satellites
- C. An amateur station that transmits telemetry consisting of measurement of upper atmosphere data from space
- D. Any amateur station on the surface of the Earth

E1D04

**A. An amateur station within 50 km of the Earth's surface intended for communications with amateur stations by means of objects in space**

ARRL Extra Manual: Page 3-12

Ham Academy Lesson: 1D

Extra Class Questions valid thru 06-30-2016  
Emergency Amateur Radio Club - [www.earchi.org/education](http://www.earchi.org/education)

E1D01 [97.3]

**What is the definition of the term telemetry?**

- A. One-way transmission of measurements at a distance from the measuring instrument
- B. Two-way radiotelephone transmissions in excess of 1000 feet
- C. Two-way single channel transmissions of data
- D. One-way transmission that initiates, modifies, or terminates the functions of a device at a distance

E1D01

**A. One-way transmission of measurements at a distance from the measuring instrument**

ARRL Extra Manual: Page 3-13

Ham Academy Lesson: 1D

Extra Class Questions valid thru 06-30-2016  
Emergency Amateur Radio Club - [www.earchi.org/education](http://www.earchi.org/education)

E1D03 [97.3]

**What is a telecommand station in the amateur satellite service?**

- A. An amateur station located on the Earth's surface for communications with other Earth stations by means of Earth satellites
- B. An amateur station that transmits communications to initiate, modify or terminate functions of a space station
- C. An amateur station located more than 50 km above the Earth's surface
- D. An amateur station that transmits telemetry consisting of measurements of upper atmosphere data from space

E1D03

**B. An amateur station that transmits communications to initiate, modify or terminate functions of a space station**

ARRL Extra Manual: Page 3-13

Ham Academy Lesson: 1D

Extra Class Questions valid thru 06-30-2016  
Emergency Amateur Radio Club - [www.earchi.org/education](http://www.earchi.org/education)

E1D05 [97.207]

**What class of licensee is authorized to be the control operator of a space station?**

- A. All except Technician Class
- B. Only General, Advanced or Amateur Extra Class
- C. All classes
- D. Only Amateur Extra Class

E1D05

**C. All classes**

ARRL Extra Manual: Page 3-13

Ham Academy Lesson: 1D

Extra Class Questions valid thru 06-30-2016  
Emergency Amateur Radio Club - [www.earchi.org/education](http://www.earchi.org/education)

E1D06 [97.207]

**Which of the following special provisions must a space station incorporate in order to comply with space station requirements?**

- A. The space station must be capable of terminating transmissions by telecommand when directed by the FCC
- B. The space station must cease all transmissions after 5 years
- C. The space station must be capable of changing its orbit whenever such a change is ordered by NASA
- D. All of these choices are correct

E1D06

**A. The space station must be capable of terminating transmissions by telecommand when directed by the FCC**

ARRL Extra Manual: Page 3-14

Ham Academy Lesson: 1D

Extra Class Questions valid thru 06-30-2016  
Emergency Amateur Radio Club - [www.earchi.org/education](http://www.earchi.org/education)

E1D07 [97.207]

**Which amateur service HF bands have frequencies authorized to space stations?**

- A. Only 40m, 20m, 17m, 15m, 12m and 10m
- B. Only 40m, 20m, 17m, 15m and 10m bands
- C. 40m, 30m, 20m, 15m, 12m and 10m bands
- D. All HF bands

E1D07

**A. Only 40m, 20m, 17m, 15m, 12m and 10m**

ARRL Extra Manual: Page 3-14

Ham Academy Lesson: 1D

Extra Class Questions valid thru 06-30-2016  
Emergency Amateur Radio Club - [www.earchi.org/education](http://www.earchi.org/education)

E1D08 [97.207]

**Which VHF amateur service bands have frequencies available for space stations?**

- A. 6 meters and 2 meters
- B. 6 meters, 2 meters, and 1.25 meters
- C. 2 meters and 1.25 meters
- D. 2 meters

E1D08

**D. 2 meters**

ARRL Extra Manual: Page 3-14

Ham Academy Lesson: 1D

Extra Class Questions valid thru 06-30-2016  
Emergency Amateur Radio Club - [www.earchi.org/education](http://www.earchi.org/education)

E1D10 [97.211]

**Which amateur stations are eligible to be telecommand stations?**

- A. Any amateur station designated by NASA
- B. Any amateur station so designated by the space station licensee, subject to the privileges of the class of operator license held by the control operator
- C. Any amateur station so designated by the ITU
- D. All of these choices are correct

E1D10

**B. Any amateur station so designated by the space station licensee, subject to the privileges of the class of operator license held by the control operator**

ARRL Extra Manual: Page 3-14

Ham Academy Lesson: 1D

Extra Class Questions valid thru 06-30-2016  
Emergency Amateur Radio Club - [www.earchi.org/education](http://www.earchi.org/education)

E1D11 [97.209]

**Which amateur stations are eligible to operate as Earth stations?**

- A. Any amateur station whose licensee has filed a pre-space notification with the FCC's International Bureau
- B. Only those of General, Advanced or Amateur Extra Class operators
- C. Only those of Amateur Extra Class operators
- D. Any amateur station, subject to the privileges of the class of operator license held by the control operator

E1D11

**D. Any amateur station, subject to the privileges of the class of operator license held by the control operator**

ARRL Extra Manual: Page 3-14

Ham Academy Lesson: 1D

Extra Class Questions valid thru 06-30-2016  
Emergency Amateur Radio Club - [www.earchi.org/education](http://www.earchi.org/education)

E1E03 [97.521]

**What is a Volunteer Examiner Coordinator?**

- A. A person who has volunteered to administer amateur operator license examinations
- B. A person who has volunteered to prepare amateur operator license examinations
- C. An organization that has entered into an agreement with the FCC to coordinate amateur operator license examinations
- D. The person who has entered into an agreement with the FCC to be the VE session manager

E1E03

**C. An organization that has entered into an agreement with the FCC to coordinate amateur operator license examinations**

ARRL Extra Manual: Page 3-14

Ham Academy Lesson: 1E

Extra Class Questions valid thru 06-30-2016  
Emergency Amateur Radio Club - [www.earchi.org/education](http://www.earchi.org/education)

E1E02 [97.523]

**Where are the questions for all written US amateur license examinations listed?**

- A. In FCC Part 97
- B. In a question pool maintained by the FCC
- C. In a question pool maintained by all the VECs
- D. In the appropriate FCC Report and Order

E1E02

**C. In a question pool maintained by all the VECs**

ARRL Extra Manual: Page 3-15

Ham Academy Lesson: 1E

Extra Class Questions valid thru 06-30-2016  
Emergency Amateur Radio Club - [www.earchi.org/education](http://www.earchi.org/education)

E1E04 [97.509, 97.525]

**Which of the following best describes the Volunteer Examiner accreditation process?**

- A. Each General, Advanced and Amateur Extra Class operator is automatically accredited as a VE when the license is granted
- B. The amateur operator applying must pass a VE examination administered by the FCC Enforcement Bureau
- C. The prospective VE obtains accreditation from the FCC
- D. The procedure by which a VEC confirms that the VE applicant meets FCC requirements to serve as an examiner

E1E04

**D. The procedure by which a VEC confirms that the VE applicant meets FCC requirements to serve as an examiner**

ARRL Extra Manual: Page 3-15

Ham Academy Lesson: 1E

Extra Class Questions valid thru 06-30-2016

Emergency Amateur Radio Club - [www.earchi.org/education](http://www.earchi.org/education)

E1E01 [97.509]

**What is the minimum number of qualified VEs required to administer an Element 4 amateur operator license examination?**

- A. 5
- B. 2
- C. 4
- D. 3

E1E01

**D. 3**

ARRL Extra Manual: Page 3-17

Ham Academy Lesson: 1E

Extra Class Questions valid thru 06-30-2016

Emergency Amateur Radio Club - [www.earchi.org/education](http://www.earchi.org/education)

E1E05 [97.503]

**What is the minimum passing score on amateur operator license examinations?**

- A. Minimum passing score of 70%
- B. Minimum passing score of 74%
- C. Minimum passing score of 80%
- D. Minimum passing score of 77%

E1E05

**B. Minimum passing score of 74%**

ARRL Extra Manual: Page 3-17

Ham Academy Lesson: 1E

Extra Class Questions valid thru 06-30-2016

Emergency Amateur Radio Club - [www.earchi.org/education](http://www.earchi.org/education)

E1E06 [97.509]

**Who is responsible for the proper conduct and necessary supervision during an amateur operator license examination session?**

- A. The VEC coordinating the session
- B. The FCC
- C. Each administering VE
- D. The VE session manager

E1E06

**C. Each administering VE**

ARRL Extra Manual: Page 3-17

Ham Academy Lesson: 1E

Extra Class Questions valid thru 06-30-2016

Emergency Amateur Radio Club - [www.earchi.org/education](http://www.earchi.org/education)

E1E07 [97.509]

**What should a VE do if a candidate fails to comply with the examiner's instructions during an amateur operator license examination?**

- A. Warn the candidate that continued failure to comply will result in termination of the examination
- B. Immediately terminate the candidate's examination
- C. Allow the candidate to complete the examination, but invalidate the results
- D. Immediately terminate everyones examination and close the session

E1E07

**B. Immediately terminate the candidate's examination**

ARRL Extra Manual: Page 3-17

Ham Academy Lesson: 1E

Extra Class Questions valid thru 06-30-2016

Emergency Amateur Radio Club - [www.earchi.org/education](http://www.earchi.org/education)

E1E08 [97.509]

**To which of the following examinees may a VE not administer an examination?**

- A. Employees of the VE
- B. Friends of the VE
- C. Relatives of the VE as listed in the FCC rules
- D. All of these choices are correct

E1E08

**C. Relatives of the VE as listed in the FCC rules**

ARRL Extra Manual: Page 3-17

Ham Academy Lesson: 1E

Extra Class Questions valid thru 06-30-2016

Emergency Amateur Radio Club - [www.earchi.org/education](http://www.earchi.org/education)

E1E10 [97.509]

**What must the administering VEs do after the administration of a successful examination for an amateur operator license?**

- A. They must collect and send the documents to the NCVEC for grading
- B. They must collect and submit the documents to the coordinating VEC for grading
- C. They must submit the application document to the coordinating VEC according to the coordinating VEC instructions
- D. They must collect and send the documents to the FCC according to instructions

E1E10

**C. They must submit the application document to the coordinating VEC according to the coordinating VEC instructions**

ARRL Extra Manual: Page 3-17

Ham Academy Lesson: 1E

Extra Class Questions valid thru 06-30-2016

Emergency Amateur Radio Club - [www.earchi.org/education](http://www.earchi.org/education)

E1E11 [97.509]

**What must the VE team do if an examinee scores a passing grade on all examination elements needed for an upgrade or new license?**

- A. Photocopy all examination documents and forward them to the FCC for processing
- B. Three VEs must certify that the examinee is qualified for the license grant and that they have complied with the administering VE requirements
- C. Issue the examinee the new or upgrade license
- D. All these choices are correct

E1E11

**B. Three VEs must certify that the examinee is qualified for the license grant and that they have complied with the administering VE requirements**

ARRL Extra Manual: Page 3-17

Ham Academy Lesson: 1E

Extra Class Questions valid thru 06-30-2016

Emergency Amateur Radio Club - [www.earchi.org/education](http://www.earchi.org/education)

E1E12 [97.509]

**What must the VE team do with the application form if the examinee does not pass the exam?**

- A. Return the application document to the examinee
- B. Maintain the application form with the VEC's records
- C. Send the application form to the FCC and inform the FCC of the grade
- D. Destroy the application form

E1E12

**A. Return the application document to the examinee**

ARRL Extra Manual: Page 3-17

Ham Academy Lesson: 1E

Extra Class Questions valid thru 06-30-2016  
Emergency Amateur Radio Club - [www.earchi.org/education](http://www.earchi.org/education)

E1E14 [97.527]

**For which types of out-of-pocket expenses do the Part 97 rules state that VEs and VECs may be reimbursed?**

- A. Preparing, processing, administering and coordinating an examination for an amateur radio license
- B. Teaching an amateur operator license examination preparation course
- C. No expenses are authorized for reimbursement
- D. Providing amateur operator license examination preparation training materials

E1E14

**A. Preparing, processing, administering and coordinating an examination for an amateur radio license**

ARRL Extra Manual: Page 3-17

Ham Academy Lesson: 1E

Extra Class Questions valid thru 06-30-2016  
Emergency Amateur Radio Club - [www.earchi.org/education](http://www.earchi.org/education)

E1E09 [97.509]

**What may be the penalty for a VE who fraudulently administers or certifies an examination?**

- A. Revocation of the VE's amateur station license grant and the suspension of the VE's amateur operator license grant
- B. A fine of up to \$1000 per occurrence
- C. A sentence of up to one year in prison
- D. All of these choices are correct

E1E09

**A. Revocation of the VE's amateur station license grant and the suspension of the VE's amateur operator license grant**

ARRL Extra Manual: Page 3-18

Ham Academy Lesson: 1E

Extra Class Questions valid thru 06-30-2016  
Emergency Amateur Radio Club - [www.earchi.org/education](http://www.earchi.org/education)

E1E13 [97.519]

**What are the consequences of failing to appear for re-administration of an examination when so directed by the FCC?**

- A. The licensee's license will be cancelled
- B. The person may be fined or imprisoned
- C. The licensee is disqualified from any future examination for an amateur operator license grant
- D. All these choices are correct

E1E13

**A. The licensee's license will be cancelled**

ARRL Extra Manual: Page 3-18

Ham Academy Lesson: 1E

Extra Class Questions valid thru 06-30-2016  
Emergency Amateur Radio Club - [www.earchi.org/education](http://www.earchi.org/education)

E1F03 [97.315]

**Under what circumstances may a dealer sell an external RF power amplifier capable of operation below 144 MHz if it has not been granted FCC certification?**

- A. It was purchased in used condition from an amateur operator and is sold to another amateur operator for use at that operator's station
- B. The equipment dealer assembled it from a kit
- C. It was imported from a manufacturer in a country that does not require certification of RF power amplifiers
- D. It was imported from a manufacturer in another country, and it was certificated by that country's government

E1F03

**A. It was purchased in used condition from an amateur operator and is sold to another amateur operator for use at that operator's station**

ARRL Extra Manual: Page 3-19

Ham Academy Lesson: 1F

Extra Class Questions valid thru 06-30-2016

Emergency Amateur Radio Club - [www.earchi.org/education](http://www.earchi.org/education)

E1F11 [97.317]

**Which of the following best describes one of the standards that must be met by an external RF power amplifier if it is to qualify for a grant of FCC certification?**

- A. It must produce full legal output when driven by not more than 5 watts of mean RF input power
- B. It must be capable of external RF switching between its input and output networks
- C. It must exhibit a gain of 0 dB or less over its full output range
- D. It must satisfy the FCC's spurious emission standards when operated at the lesser of 1500 watts, or its full output power

E1F11

**D. It must satisfy the FCC's spurious emission standards when operated at the lesser of 1500 watts, or its full output power**

ARRL Extra Manual: Page 3-19

Ham Academy Lesson: 1F

Extra Class Questions valid thru 06-30-2016

Emergency Amateur Radio Club - [www.earchi.org/education](http://www.earchi.org/education)

E1F12 [97.201]

**Who may be the control operator of an auxiliary station?**

- A. Any licensed amateur operator
- B. Only Technician, General, Advanced or Amateur Extra Class operators
- C. Only General, Advanced or Amateur Extra Class operators
- D. Only Amateur Extra Class operators

E1F12

**B. Only Technician, General, Advanced or Amateur Extra Class operators**

ARRL Extra Manual: Page 3-19

Ham Academy Lesson: 1F

Extra Class Questions valid thru 06-30-2016

Emergency Amateur Radio Club - [www.earchi.org/education](http://www.earchi.org/education)

E1F04 [97.3]

**Which of the following geographic descriptions approximately describes "Line A"?**

- A. A line roughly parallel to and south of the US-Canadian border
- B. A line roughly parallel to and west of the US Atlantic coastline
- C. A line roughly parallel to and north of the US-Mexican border and Gulf coastline
- D. A line roughly parallel to and east of the US Pacific coastline

E1F04

**A. A line roughly parallel to and south of the US-Canadian border**

ARRL Extra Manual: Page 3-20

Ham Academy Lesson: 1F

Extra Class Questions valid thru 06-30-2016

Emergency Amateur Radio Club - [www.earchi.org/education](http://www.earchi.org/education)

E1F05 [97.303]

**Amateur stations may not transmit in which of the following frequency segments if they are located in the contiguous 48 states and north of Line A?**

- A. 440 - 450 MHz
- B. 53 - 54 MHz
- C. 222 - 223 MHz
- D. 420 - 430 MHz

E1F05

**D. 420 - 430 MHz**

ARRL Extra Manual: Page 3-20

Ham Academy Lesson: 1F

Extra Class Questions valid thru 06-30-2016  
Emergency Amateur Radio Club - [www.earchi.org/education](http://www.earchi.org/education)

E1F06 [97.3]

**What is the National Radio Quiet Zone?**

- A. An area in Puerto Rico surrounding the Aricebo Radio Telescope
- B. An area in New Mexico surrounding the White Sands Test Area
- C. An area surrounding the National Radio Astronomy Observatory
- D. An area in Florida surrounding Cape Canaveral

E1F06

**C. An area surrounding the National Radio Astronomy Observatory**

ARRL Extra Manual: Page 3-20

Ham Academy Lesson: 1F

Extra Class Questions valid thru 06-30-2016  
Emergency Amateur Radio Club - [www.earchi.org/education](http://www.earchi.org/education)

E1F07 [97.113]

**When may an amateur station send a message to a business?**

- A. When the total money involved does not exceed \$25
- B. When the control operator is employed by the FCC or another government agency
- C. When transmitting international third-party communications
- D. When neither the amateur nor his or her employer has a pecuniary interest in the communications

E1F07

**D. When neither the amateur nor his or her employer has a pecuniary interest in the communications**

ARRL Extra Manual: Page 3-20

Ham Academy Lesson: 1F

Extra Class Questions valid thru 06-30-2016  
Emergency Amateur Radio Club - [www.earchi.org/education](http://www.earchi.org/education)

E1F13 [97.117]

**What types of communications may be transmitted to amateur stations in foreign countries?**

- A. Business-related messages for non-profit organizations
- B. Messages intended for connection to users of the maritime satellite service
- C. Communications incidental to the purpose of the amateur service and remarks of a personal nature
- D. All of these choices are correct

E1F13

**C. Communications incidental to the purpose of the amateur service and remarks of a personal nature**

ARRL Extra Manual: Page 3-20

Ham Academy Lesson: 1F

Extra Class Questions valid thru 06-30-2016  
Emergency Amateur Radio Club - [www.earchi.org/education](http://www.earchi.org/education)



E1F01 [97.305]

**On what frequencies are spread spectrum transmissions permitted?**

- A. Only on amateur frequencies above 50 MHz
- B. Only on amateur frequencies above 222 MHz
- C. Only on amateur frequencies above 420 MHz
- D. Only on amateur frequencies above 144 MHz

E1F01

**B. Only on amateur frequencies above 222 MHz**

ARRL Extra Manual: Page 3-21

Ham Academy Lesson: 1F

Extra Class Questions valid thru 06-30-2016  
Emergency Amateur Radio Club - [www.earchi.org/education](http://www.earchi.org/education)

E1F02 [97.5]

**Which of the following operating arrangements allows an FCC-licensed US citizen to operate in many European countries, and alien amateurs from many European countries to operate in the US?**

- A. CEPT agreement
- B. IARP agreement
- C. ITU reciprocal license
- D. All of these choices are correct

E1F02

**A. CEPT agreement**

ARRL Extra Manual: Page 3-21

Ham Academy Lesson: 1F

Extra Class Questions valid thru 06-30-2016  
Emergency Amateur Radio Club - [www.earchi.org/education](http://www.earchi.org/education)

E1F08 [97.113]

**Which of the following types of amateur station communications are prohibited?**

- A. Communications transmitted for hire or material compensation, except as otherwise provided in the rules
- B. Communications that have a political content, except as allowed by the Fairness Doctrine
- C. Communications that have a religious content
- D. Communications in a language other than English

E1F08

**A. Communications transmitted for hire or material compensation, except as otherwise provided in the rules**

ARRL Extra Manual: Page 3-21

Ham Academy Lesson: 1F

Extra Class Questions valid thru 06-30-2016  
Emergency Amateur Radio Club - [www.earchi.org/education](http://www.earchi.org/education)

E1F09 [97.311]

**Which of the following conditions apply when transmitting spread spectrum emission?**

- A. A station transmitting SS emission must not cause harmful interference to other stations employing other authorized emissions
- B. The transmitting station must be in an area regulated by the FCC or in a country that permits SS emissions
- C. The transmission must not be used to obscure the meaning of any communication
- D. All of these choices are correct

E1F09

**D. All of these choices are correct**

ARRL Extra Manual: Page 3-21

Ham Academy Lesson: 1F

Extra Class Questions valid thru 06-30-2016  
Emergency Amateur Radio Club - [www.earchi.org/education](http://www.earchi.org/education)

E1F10 [97.313]

**What is the maximum transmitter power for an amateur station transmitting spread spectrum communications?**

- A. 1 W
- B. 1.5 W
- C. 10 W
- D. 1.5 kW

E1F10

**C. 10 W**

ARRL Extra Manual: Page 3-21

Ham Academy Lesson: 1F

Extra Class Questions valid thru 06-30-2016  
Emergency Amateur Radio Club - [www.earchi.org/education](http://www.earchi.org/education)

E1F14 [1.931]

**Under what circumstances might the FCC issue a "Special Temporary Authority" (STA) to an amateur station?**

- A. To provide for experimental amateur communications
- B. To allow regular operation on Land Mobile channels
- C. To provide additional spectrum for personal use
- D. To provide temporary operation while awaiting normal licensing

E1F14

**A. To provide for experimental amateur communications**

ARRL Extra Manual: Page 3-22

Ham Academy Lesson: 1F

Extra Class Questions valid thru 06-30-2016  
Emergency Amateur Radio Club - [www.earchi.org/education](http://www.earchi.org/education)

E5C11

**What do the two numbers represent that are used to define a point on a graph using rectangular coordinates?**

- A. The magnitude and phase of the point
- B. The sine and cosine values
- C. The coordinate values along the horizontal and vertical axes
- D. The tangent and cotangent values

E5C11

**C. The coordinate values along the horizontal and vertical axes**

ARRL Extra Manual: Page 4-2

Ham Academy Lesson: 2A

Extra Class Questions valid thru 06-30-2016  
Emergency Amateur Radio Club - [www.earchi.org/education](http://www.earchi.org/education)

E5D04

**What unit measures electrical energy stored in an electrostatic field?**

- A. Coulomb
- B. Joule
- C. Watt
- D. Volt

E5D04

**B. Joule**

ARRL Extra Manual: Page 4-5

Ham Academy Lesson: 2A

Extra Class Questions valid thru 06-30-2016  
Emergency Amateur Radio Club - [www.earchi.org/education](http://www.earchi.org/education)

E5D05

**Which of the following creates a magnetic field?**

- A. Potential differences between two points in space
- B. Electric current
- C. A charged capacitor
- D. A battery

E5D05

**B. Electric current**

ARRL Extra Manual: Page 4-5

Ham Academy Lesson: 2A

Extra Class Questions valid thru 06-30-2016  
Emergency Amateur Radio Club - [www.earchi.org/education](http://www.earchi.org/education)

E5D08

**What type of energy is stored in an electromagnetic or electrostatic field?**

- A. Electromechanical energy
- B. Potential energy
- C. Thermodynamic energy
- D. Kinetic energy

E5D08

**B. Potential energy**

ARRL Extra Manual: Page 4-5

Ham Academy Lesson: 2A

Extra Class Questions valid thru 06-30-2016  
Emergency Amateur Radio Club - [www.earchi.org/education](http://www.earchi.org/education)

E5D03

**What device is used to store electrical energy in an electrostatic field?**

- A. A battery
- B. A transformer
- C. A capacitor
- D. An inductor

E5D03

**C. A capacitor**

ARRL Extra Manual: Page 4-6

Ham Academy Lesson: 2A

Extra Class Questions valid thru 06-30-2016  
Emergency Amateur Radio Club - [www.earchi.org/education](http://www.earchi.org/education)

E5D06

**In what direction is the magnetic field oriented about a conductor in relation to the direction of electron flow?**

- A. In the same direction as the current
- B. In a direction opposite to the current
- C. In all directions; omnidirectional
- D. In a direction determined by the left-hand rule

E5D06

**D. In a direction determined by the left-hand rule**

ARRL Extra Manual: Page 4-6

Ham Academy Lesson: 2A

Extra Class Questions valid thru 06-30-2016  
Emergency Amateur Radio Club - [www.earchi.org/education](http://www.earchi.org/education)

E5D07

**What determines the strength of a magnetic field around a conductor?**

- A. The resistance divided by the current
- B. The ratio of the current to the resistance
- C. The diameter of the conductor
- D. The amount of current

E5D07

**D. The amount of current**

ARRL Extra Manual: Page 4-7

Ham Academy Lesson: 2A

Extra Class Questions valid thru 06-30-2016  
Emergency Amateur Radio Club - [www.earchi.org/education](http://www.earchi.org/education)

E5B01

**What is the term for the time required for the capacitor in an RC circuit to be charged to 63.2% of the applied voltage?**

- A. An exponential rate of one
- B. One time constant
- C. One exponential period
- D. A time factor of one

E5B01

**B. One time constant**

ARRL Extra Manual: Page 4-9

Ham Academy Lesson: 2A

Extra Class Questions valid thru 06-30-2016  
Emergency Amateur Radio Club - [www.earchi.org/education](http://www.earchi.org/education)

E5B02

**What is the term for the time it takes for a charged capacitor in an RC circuit to discharge to 36.8% of its initial voltage?**

- A. One discharge period
- B. An exponential discharge rate of one
- C. A discharge factor of one
- D. One time constant

E5B02

**D. One time constant**

ARRL Extra Manual: Page 4-9

Ham Academy Lesson: 2A

Extra Class Questions valid thru 06-30-2016  
Emergency Amateur Radio Club - [www.earchi.org/education](http://www.earchi.org/education)

E5B03

**The capacitor in an RC circuit is discharged to what percentage of the starting voltage after two time constants?**

- A. 86.5%
- B. 63.2%
- C. 36.8%
- D. 13.5%

E5B03

**D. 13.5%**

ARRL Extra Manual: Page 4-9

Ham Academy Lesson: 2A

Extra Class Questions valid thru 06-30-2016  
Emergency Amateur Radio Club - [www.earchi.org/education](http://www.earchi.org/education)

E5B05

**How long does it take for an initial charge of 20 V DC to decrease to 7.36 V DC in a 0.01-microfarad capacitor when a 2-megohm resistor is connected across it?**

- A. 0.02 seconds
- B. 0.04 seconds
- C. 20 seconds
- D. 40 seconds

E5B05

**A. 0.02 seconds**

ARRL Extra Manual: Page 4-10

Ham Academy Lesson: 2A

Extra Class Questions valid thru 06-30-2016  
Emergency Amateur Radio Club - [www.earchi.org/education](http://www.earchi.org/education)

E5B04

**What is the time constant of a circuit having two 220-microfarad capacitors and two 1-megohm resistors, all in parallel?**

- A. 55 seconds
- B. 110 seconds
- C. 440 seconds
- D. 220 seconds

E5B04

**D. 220 seconds**

ARRL Extra Manual: Page 4-11

Ham Academy Lesson: 2A

Extra Class Questions valid thru 06-30-2016  
Emergency Amateur Radio Club - [www.earchi.org/education](http://www.earchi.org/education)

E5B06

**How long does it take for an initial charge of 800 V DC to decrease to 294 V DC in a 450-microfarad capacitor when a 1-megohm resistor is connected across it?**

- A. 4.50 seconds
- B. 9 seconds
- C. 450 seconds
- D. 900 seconds

E5B06

**C. 450 seconds**

ARRL Extra Manual: Page 4-11

Ham Academy Lesson: 2A

Extra Class Questions valid thru 06-30-2016  
Emergency Amateur Radio Club - [www.earchi.org/education](http://www.earchi.org/education)

E5B09

**What is the relationship between the current through a capacitor and the voltage across a capacitor?**

- A. Voltage and current are in phase
- B. Voltage and current are 180 degrees out of phase
- C. Voltage leads current by 90 degrees
- D. Current leads voltage by 90 degrees

E5B09

**D. Current leads voltage by 90 degrees**

ARRL Extra Manual: Page 4-14

Ham Academy Lesson: 2A

Extra Class Questions valid thru 06-30-2016  
Emergency Amateur Radio Club - [www.earchi.org/education](http://www.earchi.org/education)

E5B10

**What is the relationship between the current through an inductor and the voltage across an inductor?**

- A. Voltage leads current by 90 degrees
- B. Current leads voltage by 90 degrees
- C. Voltage and current are 180 degrees out of phase
- D. Voltage and current are in phase

E5B10

**A. Voltage leads current by 90 degrees**

ARRL Extra Manual: Page 4-14

Ham Academy Lesson: 2A

Extra Class Questions valid thru 06-30-2016  
Emergency Amateur Radio Club - [www.earchi.org/education](http://www.earchi.org/education)

E5C09

**When using rectangular coordinates to graph the impedance of a circuit, what does the horizontal axis represent?**

- A. Resistive component
- B. Reactive component
- C. The sum of the reactive and resistive components
- D. The difference between the resistive and reactive components

E5C09

**A. Resistive component**

ARRL Extra Manual: Page 4-17

Ham Academy Lesson: 2A

Extra Class Questions valid thru 06-30-2016  
Emergency Amateur Radio Club - [www.earchi.org/education](http://www.earchi.org/education)

E5C10

**When using rectangular coordinates to graph the impedance of a circuit, what does the vertical axis represent?**

- A. Resistive component
- B. Reactive component
- C. The sum of the reactive and resistive components
- D. The difference between the resistive and reactive components

E5C10

**B. Reactive component**

ARRL Extra Manual: Page 4-17

Ham Academy Lesson: 2A

Extra Class Questions valid thru 06-30-2016  
Emergency Amateur Radio Club - [www.earchi.org/education](http://www.earchi.org/education)

E5C13

**What coordinate system is often used to display the resistive, inductive, and/or capacitive reactance components of an impedance?**

- A. Maidenhead grid
- B. Faraday grid
- C. Elliptical coordinates
- D. Rectangular coordinates

E5C13

**D. Rectangular coordinates**

ARRL Extra Manual: Page 4-17

Ham Academy Lesson: 2A

Extra Class Questions valid thru 06-30-2016  
Emergency Amateur Radio Club - [www.earchi.org/education](http://www.earchi.org/education)

E5C14

**What coordinate system is often used to display the phase angle of a circuit containing resistance, inductive and/or capacitive reactance?**

- A. Maidenhead grid
- B. Faraday grid
- C. Elliptical coordinates
- D. Polar coordinates

E5C14

**D. Polar coordinates**

ARRL Extra Manual: Page 4-17

Ham Academy Lesson: 2A

Extra Class Questions valid thru 06-30-2016  
Emergency Amateur Radio Club - [www.earchi.org/education](http://www.earchi.org/education)

E5C12

**If you plot the impedance of a circuit using the rectangular coordinate system and find the impedance point falls on the right side of the graph on the horizontal axis, what do you know about the circuit?**

- A. It has to be a direct current circuit
- B. It contains resistance and capacitive reactance
- C. It contains resistance and inductive reactance
- D. It is equivalent to a pure resistance

E5C12

**D. It is equivalent to a pure resistance**

ARRL Extra Manual: Page 4-18

Ham Academy Lesson: 2A

Extra Class Questions valid thru 06-30-2016  
Emergency Amateur Radio Club - [www.earchi.org/education](http://www.earchi.org/education)

E5C15

**In polar coordinates, what is the impedance of a circuit of 100 -j100 ohms impedance?**

- A. 141 ohms at an angle of -45 degrees
- B. 100 ohms at an angle of 45 degrees
- C. 100 ohms at an angle of -45 degrees
- D. 141 ohms at an angle of 45 degrees

E5C15

**A. 141 ohms at an angle of -45 degrees**

ARRL Extra Manual: Page 4-18

Ham Academy Lesson: 2B

Extra Class Questions valid thru 06-30-2016  
Emergency Amateur Radio Club - [www.earchi.org/education](http://www.earchi.org/education)

E5C01

**In polar coordinates, what is the impedance of a network consisting of a 100-ohm-reactance inductor in series with a 100-ohm resistor?**

- A. 121 ohms at an angle of 35 degrees
- B. 141 ohms at an angle of 45 degrees
- C. 161 ohms at an angle of 55 degrees
- D. 181 ohms at an angle of 65 degrees

E5C01

**B. 141 ohms at an angle of 45 degrees**

ARRL Extra Manual: Page 4-19

Ham Academy Lesson: 2B

Extra Class Questions valid thru 06-30-2016  
Emergency Amateur Radio Club - [www.earchi.org/education](http://www.earchi.org/education)

E5C16

**In polar coordinates, what is the impedance of a circuit that has an admittance of 7.09 millisiemens at 45 degrees?**

- A. 5.03 E-06 ohms at an angle of 45 degrees
- B. 141 ohms at an angle of -45 degrees
- C. 19,900 ohms at an angle of -45 degrees
- D. 141 ohms at an angle of 45 degrees

E5C16

**B. 141 ohms at an angle of -45 degrees**

ARRL Extra Manual: Page 4-19

Ham Academy Lesson: 2B

Extra Class Questions valid thru 06-30-2016  
Emergency Amateur Radio Club - [www.earchi.org/education](http://www.earchi.org/education)

E5C17

**In rectangular coordinates, what is the impedance of a circuit that has an admittance of 5 millisiemens at -30 degrees?**

- A. 173 - j100 ohms
- B. 200 + j100 ohms
- C. 173 + j100 ohms
- D. 200 - j100 ohms

E5C17

**C. 173 + j100 ohms**

ARRL Extra Manual: Page 4-19

Ham Academy Lesson: 2B

Extra Class Questions valid thru 06-30-2016  
Emergency Amateur Radio Club - [www.earchi.org/education](http://www.earchi.org/education)

E5C06

**In polar coordinates, what is the impedance of a network consisting of a 100-ohm-reactance capacitor in series with a 100-ohm resistor?**

- A. 121 ohms at an angle of -25 degrees
- B. 191 ohms at an angle of -85 degrees
- C. 161 ohms at an angle of -65 degrees
- D. 141 ohms at an angle of -45 degrees

E5C06

**D. 141 ohms at an angle of -45 degrees**

ARRL Extra Manual: Page 4-20

Ham Academy Lesson: 2B

Extra Class Questions valid thru 06-30-2016  
Emergency Amateur Radio Club - [www.earchi.org/education](http://www.earchi.org/education)

E5C08

**In polar coordinates, what is the impedance of a network comprised of a 300-ohm-reactance inductor in series with a 400-ohm resistor?**

- A. 400 ohms at an angle of 27 degrees
- B. 500 ohms at an angle of 37 degrees
- C. 500 ohms at an angle of 47 degrees
- D. 700 ohms at an angle of 57 degrees

E5C08

**B. 500 ohms at an angle of 37 degrees**

ARRL Extra Manual: Page 4-20

Ham Academy Lesson: 2B

Extra Class Questions valid thru 06-30-2016  
Emergency Amateur Radio Club - [www.earchi.org/education](http://www.earchi.org/education)



E5C20

**Which point in Figure E5-2 best represents the impedance of a series circuit consisting of a 300 ohm resistor and an 18 microhenry inductor at 3.505 MHz?**

- A. Point 1
- B. Point 3
- C. Point 7
- D. Point 8

E5C20

**B. Point 3**

ARRL Extra Manual: Page 4-21

Ham Academy Lesson: 2B

Extra Class Questions valid thru 06-30-2016  
Emergency Amateur Radio Club - [www.earchi.org/education](http://www.earchi.org/education)

E5C22

**In rectangular coordinates, what is the impedance of a network consisting of a 10-microhenry inductor in series with a 40-ohm resistor at 500 MHz?**

- A.  $40 + j31,400$
- B.  $40 - j31,400$
- C.  $31,400 + j40$
- D.  $31,400 - j40$

E5C22

**A.  $40 + j31,400$**

ARRL Extra Manual: Page 4-21

Ham Academy Lesson: 2B

Extra Class Questions valid thru 06-30-2016  
Emergency Amateur Radio Club - [www.earchi.org/education](http://www.earchi.org/education)

E5C04

**In polar coordinates, what is the impedance of a network consisting of a 400-ohm-reactance capacitor in series with a 300-ohm resistor?**

- A. 240 ohms at an angle of 36.9 degrees
- B. 240 ohms at an angle of -36.9 degrees
- C. 500 ohms at an angle of 53.1 degrees
- D. 500 ohms at an angle of -53.1 degrees

E5C04

**D. 500 ohms at an angle of -53.1 degrees**

ARRL Extra Manual: Page 4-22

Ham Academy Lesson: 2B

Extra Class Questions valid thru 06-30-2016  
Emergency Amateur Radio Club - [www.earchi.org/education](http://www.earchi.org/education)

E5C19

**Which point on Figure E5-2 best represents that impedance of a series circuit consisting of a 400 ohm resistor and a 38 picofarad capacitor at 14 MHz?**

- A. Point 2
- B. Point 4
- C. Point 5
- D. Point 6

E5C19

**B. Point 4**

ARRL Extra Manual: Page 4-22

Ham Academy Lesson: 2B

Extra Class Questions valid thru 06-30-2016  
Emergency Amateur Radio Club - [www.earchi.org/education](http://www.earchi.org/education)

E5C21

**Which point on Figure E5-2 best represents the impedance of a series circuit consisting of a 300 ohm resistor and a 19 picofarad capacitor at 21.200 MHz?**

- A. Point 1
- B. Point 3
- C. Point 7
- D. Point 8

E5C21

**A. Point 1**

ARRL Extra Manual: Page 4-22

Ham Academy Lesson: 2B

Extra Class Questions valid thru 06-30-2016  
Emergency Amateur Radio Club - [www.earchi.org/education](http://www.earchi.org/education)

E5C02

**In polar coordinates, what is the impedance of a network consisting of a 100-ohm-reactance inductor, a 100-ohm-reactance capacitor, and a 100-ohm resistor, all connected in series?**

- A. 100 ohms at an angle of 90 degrees
- B. 10 ohms at an angle of 0 degrees
- C. 10 ohms at an angle of 90 degrees
- D. 100 ohms at an angle of 0 degrees

E5C02

**D. 100 ohms at an angle of 0 degrees**

ARRL Extra Manual: Page 4-23

Ham Academy Lesson: 2B

Extra Class Questions valid thru 06-30-2016  
Emergency Amateur Radio Club - [www.earchi.org/education](http://www.earchi.org/education)

E5C18

**In polar coordinates, what is the impedance of a series circuit consisting of a resistance of 4 ohms, an inductive reactance of 4 ohms, and a capacitive reactance of 1 ohm?**

- A. 6.4 ohms at an angle of 53 degrees
- B. 5 ohms at an angle of 37 degrees
- C. 5 ohms at an angle of 45 degrees
- D. 10 ohms at an angle of -51 degrees

E5C18

**B. 5 ohms at an angle of 37 degrees**

ARRL Extra Manual: Page 4-23

Ham Academy Lesson: 2B

Extra Class Questions valid thru 06-30-2016  
Emergency Amateur Radio Club - [www.earchi.org/education](http://www.earchi.org/education)

E5C03

**In polar coordinates, what is the impedance of a network consisting of a 300-ohm-reactance capacitor, a 600-ohm-reactance inductor, and a 400-ohm resistor, all connected in series?**

- A. 500 ohms at an angle of 37 degrees
- B. 900 ohms at an angle of 53 degrees
- C. 400 ohms at an angle of 0 degrees
- D. 1300 ohms at an angle of 180 degrees

E5C03

**A. 500 ohms at an angle of 37 degrees**

ARRL Extra Manual: Page 4-24

Ham Academy Lesson: 2B

Extra Class Questions valid thru 06-30-2016  
Emergency Amateur Radio Club - [www.earchi.org/education](http://www.earchi.org/education)

E5C05

**In polar coordinates, what is the impedance of a network consisting of a 400-ohm-reactance inductor in parallel with a 300-ohm resistor?**

- A. 240 ohms at an angle of 36.9 degrees
- B. 240 ohms at an angle of -36.9 degrees
- C. 500 ohms at an angle of 53.1 degrees
- D. 500 ohms at an angle of -53.1 degrees

E5C05

**A. 240 ohms at an angle of 36.9 degrees**

ARRL Extra Manual: Page 4-24

Ham Academy Lesson: 2B

Extra Class Questions valid thru 06-30-2016  
Emergency Amateur Radio Club - [www.earchi.org/education](http://www.earchi.org/education)

E5C07

**In polar coordinates, what is the impedance of a network comprised of a 100-ohm-reactance capacitor in parallel with a 100-ohm resistor?**

- A. 31 ohms at an angle of -15 degrees
- B. 51 ohms at an angle of -25 degrees
- C. 71 ohms at an angle of -45 degrees
- D. 91 ohms at an angle of -65 degrees

E5C07

**C. 71 ohms at an angle of -45 degrees**

ARRL Extra Manual: Page 4-25

Ham Academy Lesson: 2B

Extra Class Questions valid thru 06-30-2016  
Emergency Amateur Radio Club - [www.earchi.org/education](http://www.earchi.org/education)

E5B07

**What is the phase angle between the voltage across and the current through a series RLC circuit if XC is 500 ohms, R is 1 kilohm, and XL is 250 ohms?**

- A. 68.2 degrees with the voltage leading the current
- B. 14.0 degrees with the voltage leading the current
- C. 14.0 degrees with the voltage lagging the current
- D. 68.2 degrees with the voltage lagging the current

E5B07

**C. 14.0 degrees with the voltage lagging the current**

ARRL Extra Manual: Page 4-26

Ham Academy Lesson: 2B

Extra Class Questions valid thru 06-30-2016  
Emergency Amateur Radio Club - [www.earchi.org/education](http://www.earchi.org/education)

E5C23

**Which point on Figure E5-2 best represents the impedance of a series circuit consisting of a 300-ohm resistor, a 0.64-microhenry inductor and an 85-picofarad capacitor at 24.900 MHz?**

- A. Point 1
- B. Point 3
- C. Point 5
- D. Point 8

E5C23

**D. Point 8**

ARRL Extra Manual: Page 4-26

Ham Academy Lesson: 2B

Extra Class Questions valid thru 06-30-2016  
Emergency Amateur Radio Club - [www.earchi.org/education](http://www.earchi.org/education)

E5B08

**What is the phase angle between the voltage across and the current through a series RLC circuit if XC is 100 ohms, R is 100 ohms, and XL is 75 ohms?**

- A. 14 degrees with the voltage lagging the current
- B. 14 degrees with the voltage leading the current
- C. 76 degrees with the voltage leading the current
- D. 76 degrees with the voltage lagging the current

E5B08

**A. 14 degrees with the voltage lagging the current**

ARRL Extra Manual: Page 4-27

Ham Academy Lesson: 2B

Extra Class Questions valid thru 06-30-2016  
Emergency Amateur Radio Club - [www.earchi.org/education](http://www.earchi.org/education)

E5B11

**What is the phase angle between the voltage across and the current through a series RLC circuit if XC is 25 ohms, R is 100 ohms, and XL is 50 ohms?**

- A. 14 degrees with the voltage lagging the current
- B. 14 degrees with the voltage leading the current
- C. 76 degrees with the voltage lagging the current
- D. 76 degrees with the voltage leading the current

E5B11

**B. 14 degrees with the voltage leading the current**

ARRL Extra Manual: Page 4-27

Ham Academy Lesson: 2B

Extra Class Questions valid thru 06-30-2016  
Emergency Amateur Radio Club - [www.earchi.org/education](http://www.earchi.org/education)

E5B12

**What is the phase angle between the voltage across and the current through a series RLC circuit if XC is 75 ohms, R is 100 ohms, and XL is 50 ohms?**

- A. 76 degrees with the voltage lagging the current
- B. 14 degrees with the voltage leading the current
- C. 14 degrees with the voltage lagging the current
- D. 76 degrees with the voltage leading the current

E5B12

**C. 14 degrees with the voltage lagging the current**

ARRL Extra Manual: Page 4-28

Ham Academy Lesson: 2B

Extra Class Questions valid thru 06-30-2016  
Emergency Amateur Radio Club - [www.earchi.org/education](http://www.earchi.org/education)

E5B13

**What is the phase angle between the voltage across and the current through a series RLC circuit if XC is 250 ohms, R is 1 kilohm, and XL is 500 ohms?**

- A. 81.47 degrees with the voltage lagging the current
- B. 81.47 degrees with the voltage leading the current
- C. 14.04 degrees with the voltage lagging the current
- D. 14.04 degrees with the voltage leading the current

E5B13

**D. 14.04 degrees with the voltage leading the current**

ARRL Extra Manual: Page 4-28

Ham Academy Lesson: 2B

Extra Class Questions valid thru 06-30-2016  
Emergency Amateur Radio Club - [www.earchi.org/education](http://www.earchi.org/education)

E5D09

**What happens to reactive power in an AC circuit that has both ideal inductors and ideal capacitors?**

- A. It is dissipated as heat in the circuit
- B. It is repeatedly exchanged between the associated magnetic and electric fields, but is not dissipated
- C. It is dissipated as kinetic energy in the circuit
- D. It is dissipated in the formation of inductive and capacitive fields

E5D09

**B. It is repeatedly exchanged between the associated magnetic and electric fields, but is not dissipated**

ARRL Extra Manual: Page 4-29

Ham Academy Lesson: 2B

Extra Class Questions valid thru 06-30-2016  
Emergency Amateur Radio Club - [www.earchi.org/education](http://www.earchi.org/education)

E5D14

**What is reactive power?**

- A. Wattless, nonproductive power
- B. Power consumed in wire resistance in an inductor
- C. Power lost because of capacitor leakage
- D. Power consumed in circuit Q

E5D14

**A. Wattless, nonproductive power**

ARRL Extra Manual: Page 4-29

Ham Academy Lesson: 2B

Extra Class Questions valid thru 06-30-2016  
Emergency Amateur Radio Club - [www.earchi.org/education](http://www.earchi.org/education)

E5D10

**How can the true power be determined in an AC circuit where the voltage and current are out of phase?**

- A. By multiplying the apparent power times the power factor
- B. By dividing the reactive power by the power factor
- C. By dividing the apparent power by the power factor
- D. By multiplying the reactive power times the power factor

E5D10

**A. By multiplying the apparent power times the power factor**

ARRL Extra Manual: Page 4-30

Ham Academy Lesson: 2B

Extra Class Questions valid thru 06-30-2016  
Emergency Amateur Radio Club - [www.earchi.org/education](http://www.earchi.org/education)

E5D11

**What is the power factor of an R-L circuit having a 60 degree phase angle between the voltage and the current?**

- A. 1.414
- B. 0.866
- C. 0.5
- D. 1.73

E5D11

**C. 0.5**

ARRL Extra Manual: Page 4-31

Ham Academy Lesson: 2B

Extra Class Questions valid thru 06-30-2016  
Emergency Amateur Radio Club - [www.earchi.org/education](http://www.earchi.org/education)

E5D12

**How many watts are consumed in a circuit having a power factor of 0.2 if the input is 100-V AC at 4 amperes?**

- A. 400 watts
- B. 80 watts
- C. 2000 watts
- D. 50 watts

E5D12

**B. 80 watts**

ARRL Extra Manual: Page 4-31

Ham Academy Lesson: 2B

Extra Class Questions valid thru 06-30-2016  
Emergency Amateur Radio Club - [www.earchi.org/education](http://www.earchi.org/education)

E5D13

**How much power is consumed in a circuit consisting of a 100 ohm resistor in series with a 100 ohm inductive reactance drawing 1 ampere?**

- A. 70.7 Watts
- B. 100 Watts
- C. 141.4 Watts
- D. 200 Watts

E5D13

**B. 100 Watts**

ARRL Extra Manual: Page 4-31

Ham Academy Lesson: 2B

Extra Class Questions valid thru 06-30-2016  
Emergency Amateur Radio Club - [www.earchi.org/education](http://www.earchi.org/education)

E5D15

**What is the power factor of an RL circuit having a 45 degree phase angle between the voltage and the current?**

- A. 0.866
- B. 1.0
- C. 0.5
- D. 0.707

E5D15

**D. 0.707**

ARRL Extra Manual: Page 4-31

Ham Academy Lesson: 2B

Extra Class Questions valid thru 06-30-2016  
Emergency Amateur Radio Club - [www.earchi.org/education](http://www.earchi.org/education)

E5D16

**What is the power factor of an RL circuit having a 30 degree phase angle between the voltage and the current?**

- A. 1.73
- B. 0.5
- C. 0.866
- D. 0.577

E5D16

**C. 0.866**

ARRL Extra Manual: Page 4-31

Ham Academy Lesson: 2B

Extra Class Questions valid thru 06-30-2016  
Emergency Amateur Radio Club - [www.earchi.org/education](http://www.earchi.org/education)

E5D17

**How many watts are consumed in a circuit having a power factor of 0.6 if the input is 200V AC at 5 amperes?**

- A. 200 watts
- B. 1000 watts
- C. 1600 watts
- D. 600 watts

E5D17

**D. 600 watts**

ARRL Extra Manual: Page 4-31

Ham Academy Lesson: 2B

Extra Class Questions valid thru 06-30-2016  
Emergency Amateur Radio Club - [www.earchi.org/education](http://www.earchi.org/education)

E5A02

**What is resonance in an electrical circuit?**

- A. The highest frequency that will pass current
- B. The lowest frequency that will pass current
- C. The frequency at which the capacitive reactance equals the inductive reactance
- D. The frequency at which the reactive impedance equals the resistive impedance

E5A02

**C. The frequency at which the capacitive reactance equals the inductive reactance**

ARRL Extra Manual: Page 4-32

Ham Academy Lesson: 2B

Extra Class Questions valid thru 06-30-2016  
Emergency Amateur Radio Club - [www.earchi.org/education](http://www.earchi.org/education)

E5D18

**How many watts are consumed in a circuit having a power factor of 0.71 if the apparent power is 500 VA?**

- A. 704 W
- B. 355 W
- C. 252 W
- D. 1.42 mW

E5D18

**B. 355 W**

ARRL Extra Manual: Page 4-32

Ham Academy Lesson: 2B

Extra Class Questions valid thru 06-30-2016  
Emergency Amateur Radio Club - [www.earchi.org/education](http://www.earchi.org/education)

E5A01

**What can cause the voltage across reactances in series to be larger than the voltage applied to them?**

- A. Resonance
- B. Capacitance
- C. Conductance
- D. Resistance

E5A01

**A. Resonance**

ARRL Extra Manual: Page 4-33

Ham Academy Lesson: 2C

Extra Class Questions valid thru 06-30-2016  
Emergency Amateur Radio Club - [www.earchi.org/education](http://www.earchi.org/education)

E5A03

**What is the magnitude of the impedance of a series RLC circuit at resonance?**

- A. High, as compared to the circuit resistance
- B. Approximately equal to capacitive reactance
- C. Approximately equal to inductive reactance
- D. Approximately equal to circuit resistance

E5A03

**D. Approximately equal to circuit resistance**

ARRL Extra Manual: Page 4-33

Ham Academy Lesson: 2C

Extra Class Questions valid thru 06-30-2016  
Emergency Amateur Radio Club - [www.earchi.org/education](http://www.earchi.org/education)

E5A05

**What is the magnitude of the current at the input of a series RLC circuit as the frequency goes through resonance?**

- A. Minimum
- B. Maximum
- C. R/L
- D. L/R

E5A05

**B. Maximum**

ARRL Extra Manual: Page 4-33

Ham Academy Lesson: 2C

Extra Class Questions valid thru 06-30-2016  
Emergency Amateur Radio Club - [www.earchi.org/education](http://www.earchi.org/education)

E5A14

**What is the resonant frequency of a series RLC circuit if R is 22 ohms, L is 50 microhenrys and C is 40 picofarads?**

- A. 44.72 MHz
- B. 22.36 MHz
- C. 3.56 MHz
- D. 1.78 MHz

E5A14

**C. 3.56 MHz**

ARRL Extra Manual: Page 4-33

Ham Academy Lesson: 2C

Extra Class Questions valid thru 06-30-2016  
Emergency Amateur Radio Club - [www.earchi.org/education](http://www.earchi.org/education)

E5A04

**What is the magnitude of the impedance of a circuit with a resistor, an inductor and a capacitor all in parallel, at resonance?**

- A. Approximately equal to circuit resistance
- B. Approximately equal to inductive reactance
- C. Low, as compared to the circuit resistance
- D. Approximately equal to capacitive reactance

E5A04

**A. Approximately equal to circuit resistance**

ARRL Extra Manual: Page 4-34

Ham Academy Lesson: 2C

Extra Class Questions valid thru 06-30-2016  
Emergency Amateur Radio Club - [www.earchi.org/education](http://www.earchi.org/education)



E5A06

**What is the magnitude of the circulating current within the components of a parallel LC circuit at resonance?**

- A. It is at a minimum
- B. It is at a maximum
- C. It equals 1 divided by the quantity 2 times Pi, multiplied by the square root of inductance L multiplied by capacitance C
- D. It equals 2 multiplied by Pi, multiplied by frequency "F", multiplied by inductance "L"

E5A06

**B. It is at a maximum**

ARRL Extra Manual: Page 4-34

Ham Academy Lesson: 2C

Extra Class Questions valid thru 06-30-2016  
Emergency Amateur Radio Club - [www.earchi.org/education](http://www.earchi.org/education)

E5A07

**What is the magnitude of the current at the input of a parallel RLC circuit at resonance?**

- A. Minimum
- B. Maximum
- C. R/L
- D. L/R

E5A07

**A. Minimum**

ARRL Extra Manual: Page 4-34

Ham Academy Lesson: 2C

Extra Class Questions valid thru 06-30-2016  
Emergency Amateur Radio Club - [www.earchi.org/education](http://www.earchi.org/education)

E5A15

**What is the resonant frequency of a series RLC circuit if R is 56 ohms, L is 40 microhenrys and C is 200 picofarads?**

- A. 3.76 MHz
- B. 1.78 MHz
- C. 11.18 MHz
- D. 22.36 MHz

E5A15

**B. 1.78 MHz**

ARRL Extra Manual: Page 4-34

Ham Academy Lesson: 2C

Extra Class Questions valid thru 06-30-2016  
Emergency Amateur Radio Club - [www.earchi.org/education](http://www.earchi.org/education)

E5A08

**What is the phase relationship between the current through and the voltage across a series resonant circuit at resonance?**

- A. The voltage leads the current by 90 degrees
- B. The current leads the voltage by 90 degrees
- C. The voltage and current are in phase
- D. The voltage and current are 180 degrees out of phase

E5A08

**C. The voltage and current are in phase**

ARRL Extra Manual: Page 4-35

Ham Academy Lesson: 2C

Extra Class Questions valid thru 06-30-2016  
Emergency Amateur Radio Club - [www.earchi.org/education](http://www.earchi.org/education)

E5A09

**What is the phase relationship between the current through and the voltage across a parallel resonant circuit at resonance?**

- A. The voltage leads the current by 90 degrees
- B. The current leads the voltage by 90 degrees
- C. The voltage and current are in phase
- D. The voltage and current are 180 degrees out of phase

E5A09

**C. The voltage and current are in phase**

ARRL Extra Manual: Page 4-35

Ham Academy Lesson: 2C

Extra Class Questions valid thru 06-30-2016  
Emergency Amateur Radio Club - [www.earchi.org/education](http://www.earchi.org/education)

E5A16

**What is the resonant frequency of a parallel RLC circuit if R is 33 ohms, L is 50 microhenrys and C is 10 picofarads?**

- A. 23.5 MHz
- B. 23.5 kHz
- C. 7.12 kHz
- D. 7.12 MHz

E5A16

**D. 7.12 MHz**

ARRL Extra Manual: Page 4-35

Ham Academy Lesson: 2C

Extra Class Questions valid thru 06-30-2016  
Emergency Amateur Radio Club - [www.earchi.org/education](http://www.earchi.org/education)

E5A17

**What is the resonant frequency of a parallel RLC circuit if R is 47 ohms, L is 25 microhenrys and C is 10 picofarads?**

- A. 10.1 MHz
- B. 63.2 MHz
- C. 10.1 kHz
- D. 63.2 kHz

E5A17

**A. 10.1 MHz**

ARRL Extra Manual: Page 4-35

Ham Academy Lesson: 2C

Extra Class Questions valid thru 06-30-2016  
Emergency Amateur Radio Club - [www.earchi.org/education](http://www.earchi.org/education)

E4B15

**Which of the following can be used as a relative measurement of the Q for a series-tuned circuit?**

- A. The inductance to capacitance ratio
- B. The frequency shift
- C. The bandwidth of the circuit's frequency response
- D. The resonant frequency of the circuit

E4B15

**C. The bandwidth of the circuit's frequency response**

ARRL Extra Manual: Page 4-37

Ham Academy Lesson: 2C

Extra Class Questions valid thru 06-30-2016  
Emergency Amateur Radio Club - [www.earchi.org/education](http://www.earchi.org/education)

E5A10

**What is the half-power bandwidth of a parallel resonant circuit that has a resonant frequency of 1.8 MHz and a Q of 95?**

- A. 18.9 kHz
- B. 1.89 kHz
- C. 94.5 kHz
- D. 9.45 kHz

E5A10

**A. 18.9 kHz**

ARRL Extra Manual: Page 4-37

Ham Academy Lesson: 2C

Extra Class Questions valid thru 06-30-2016  
Emergency Amateur Radio Club - [www.earchi.org/education](http://www.earchi.org/education)

E5A11

**What is the half-power bandwidth of a parallel resonant circuit that has a resonant frequency of 7.1 MHz and a Q of 150?**

- A. 157.8 Hz
- B. 315.6 Hz
- C. 47.3 kHz
- D. 23.67 kHz

E5A11

**C. 47.3 kHz**

ARRL Extra Manual: Page 4-37

Ham Academy Lesson: 2C

Extra Class Questions valid thru 06-30-2016  
Emergency Amateur Radio Club - [www.earchi.org/education](http://www.earchi.org/education)

E5A12

**What is the half-power bandwidth of a parallel resonant circuit that has a resonant frequency of 3.7 MHz and a Q of 118?**

- A. 436.6 kHz
- B. 218.3 kHz
- C. 31.4 kHz
- D. 15.7 kHz

E5A12

**C. 31.4 kHz**

ARRL Extra Manual: Page 4-37

Ham Academy Lesson: 2C

Extra Class Questions valid thru 06-30-2016  
Emergency Amateur Radio Club - [www.earchi.org/education](http://www.earchi.org/education)

E5A13

**What is the half-power bandwidth of a parallel resonant circuit that has a resonant frequency of 14.25 MHz and a Q of 187?**

- A. 38.1 kHz
- B. 76.2 kHz
- C. 1.332 kHz
- D. 2.665 kHz

E5A13

**B. 76.2 kHz**

ARRL Extra Manual: Page 4-37

Ham Academy Lesson: 2C

Extra Class Questions valid thru 06-30-2016  
Emergency Amateur Radio Club - [www.earchi.org/education](http://www.earchi.org/education)

E5D01

**What is the result of skin effect?**

- A. As frequency increases, RF current flows in a thinner layer of the conductor, closer to the surface
- B. As frequency decreases, RF current flows in a thinner layer of the conductor, closer to the surface
- C. Thermal effects on the surface of the conductor increase the impedance
- D. Thermal effects on the surface of the conductor decrease the impedance

E5D01

**A. As frequency increases, RF current flows in a thinner layer of the conductor, closer to the surface**

ARRL Extra Manual: Page 4-37

Ham Academy Lesson: 2C

Extra Class Questions valid thru 06-30-2016  
Emergency Amateur Radio Club - [www.earchi.org/education](http://www.earchi.org/education)

E5D02

**Why is the resistance of a conductor different for RF currents than for direct currents?**

- A. Because the insulation conducts current at high frequencies
- B. Because of the Heisenburg Effect
- C. Because of skin effect
- D. Because conductors are non-linear devices

E5D02

**C. Because of skin effect**

ARRL Extra Manual: Page 4-37

Ham Academy Lesson: 2C

Extra Class Questions valid thru 06-30-2016  
Emergency Amateur Radio Club - [www.earchi.org/education](http://www.earchi.org/education)

E6D06

**What core material property determines the inductance of a toroidal inductor?**

- A. Thermal impedance
- B. Resistance
- C. Reactivity
- D. Permeability

E6D06

**D. Permeability**

ARRL Extra Manual: Page 4-38

Ham Academy Lesson: 2C

Extra Class Questions valid thru 06-30-2016  
Emergency Amateur Radio Club - [www.earchi.org/education](http://www.earchi.org/education)

E6D08

**What is one important reason for using powdered-iron toroids rather than ferrite toroids in an inductor?**

- A. Powdered-iron toroids generally have greater initial permeability
- B. Powdered-iron toroids generally maintain their characteristics at higher currents
- C. Powdered-iron toroids generally require fewer turns to produce a given inductance value
- D. Powdered-iron toroids have higher power handling capacity

E6D08

**B. Powdered-iron toroids generally maintain their characteristics at higher currents**

ARRL Extra Manual: Page 4-38

Ham Academy Lesson: 2C

Extra Class Questions valid thru 06-30-2016  
Emergency Amateur Radio Club - [www.earchi.org/education](http://www.earchi.org/education)

E6D16

**What is one reason for using ferrite toroids rather than powdered-iron toroids in an inductor?**

- A. Ferrite toroids generally have lower initial permeabilities
- B. Ferrite toroids generally have better temperature stability
- C. Ferrite toroids generally require fewer turns to produce a given inductance value
- D. Ferrite toroids are easier to use with surface mount technology

E6D16

**C. Ferrite toroids generally require fewer turns to produce a given inductance value**

ARRL Extra Manual: Page 4-38

Ham Academy Lesson: 2C

Extra Class Questions valid thru 06-30-2016  
Emergency Amateur Radio Club - [www.earchi.org/education](http://www.earchi.org/education)

E6D07

**What is the usable frequency range of inductors that use toroidal cores, assuming a correct selection of core material for the frequency being used?**

- A. From a few kHz to no more than 30 MHz
- B. From less than 20 Hz to approximately 300 MHz
- C. From approximately 10 Hz to no more than 3000 kHz
- D. From about 100 kHz to at least 1000 GHz

E6D07

**B. From less than 20 Hz to approximately 300 MHz**

ARRL Extra Manual: Page 4-39

Ham Academy Lesson: 2C

Extra Class Questions valid thru 06-30-2016  
Emergency Amateur Radio Club - [www.earchi.org/education](http://www.earchi.org/education)

E6D10

**What is a primary advantage of using a toroidal core instead of a solenoidal core in an inductor?**

- A. Toroidal cores confine most of the magnetic field within the core material
- B. Toroidal cores make it easier to couple the magnetic energy into other components
- C. Toroidal cores exhibit greater hysteresis
- D. Toroidal cores have lower Q characteristics

E6D10

**A. Toroidal cores confine most of the magnetic field within the core material**

ARRL Extra Manual: Page 4-39

Ham Academy Lesson: 2C

Extra Class Questions valid thru 06-30-2016  
Emergency Amateur Radio Club - [www.earchi.org/education](http://www.earchi.org/education)

E6D11

**How many turns will be required to produce a 1-mH inductor using a ferrite toroidal core that has an inductance index (A L) value of 523 millihenrys/1000 turns?**

- A. 2 turns
- B. 4 turns
- C. 43 turns
- D. 229 turns

E6D11

**C. 43 turns**

ARRL Extra Manual: Page 4-40

Ham Academy Lesson: 2C

Extra Class Questions valid thru 06-30-2016  
Emergency Amateur Radio Club - [www.earchi.org/education](http://www.earchi.org/education)

E6D12

**How many turns will be required to produce a 5-microhenry inductor using a powdered-iron toroidal core that has an inductance index (A L) value of 40 microhenrys/100 turns?**

- A. 35 turns
- B. 13 turns
- C. 79 turns
- D. 141 turns

E6D12

**A. 35 turns**

ARRL Extra Manual: Page 4-40

Ham Academy Lesson: 2C

Extra Class Questions valid thru 06-30-2016  
Emergency Amateur Radio Club - [www.earchi.org/education](http://www.earchi.org/education)

E6D09

**What devices are commonly used as VHF and UHF parasitic suppressors at the input and output terminals of transistorized HF amplifiers?**

- A. Electrolytic capacitors
- B. Butterworth filters
- C. Ferrite beads
- D. Steel-core toroids

E6D09

**C. Ferrite beads**

ARRL Extra Manual: Page 4-41

Ham Academy Lesson: 2C

Extra Class Questions valid thru 06-30-2016  
Emergency Amateur Radio Club - [www.earchi.org/education](http://www.earchi.org/education)

E6A02

**Which of the following semiconductor materials contains excess free electrons?**

- A. N-type
- B. P-type
- C. Bipolar
- D. Insulated gate

E6A02

**A. N-type**

ARRL Extra Manual: Page 5-2

Ham Academy Lesson: 3A

Extra Class Questions valid thru 06-30-2016  
Emergency Amateur Radio Club - [www.earchi.org/education](http://www.earchi.org/education)

E6A04

**What is the name given to an impurity atom that adds holes to a semiconductor crystal structure?**

- A. Insulator impurity
- B. N-type impurity
- C. Acceptor impurity
- D. Donor impurity

E6A04

**C. Acceptor impurity**

ARRL Extra Manual: Page 5-2

Ham Academy Lesson: 3A

Extra Class Questions valid thru 06-30-2016  
Emergency Amateur Radio Club - [www.earchi.org/education](http://www.earchi.org/education)

E6A15

**Which of the following semiconductor materials contains an excess of holes in the outer shell of electrons?**

- A. N-type
- B. P-type
- C. Superconductor-type
- D. Bipolar-type

E6A15

**B. P-type**

ARRL Extra Manual: Page 5-2

Ham Academy Lesson: 3A

Extra Class Questions valid thru 06-30-2016  
Emergency Amateur Radio Club - [www.earchi.org/education](http://www.earchi.org/education)

E6A01

**In what application is gallium arsenide used as a semiconductor material in preference to germanium or silicon?**

- A. In high-current rectifier circuits
- B. In high-power audio circuits
- C. At microwave frequencies
- D. At very low frequency RF circuits

E6A01

**C. At microwave frequencies**

ARRL Extra Manual: Page 5-3

Ham Academy Lesson: 3A

Extra Class Questions valid thru 06-30-2016  
Emergency Amateur Radio Club - [www.earchi.org/education](http://www.earchi.org/education)

E6A03

**What are the majority charge carriers in P-type semiconductor material?**

- A. Free neutrons
- B. Free protons
- C. Holes
- D. Free electrons

E6A03

**C. Holes**

ARRL Extra Manual: Page 5-3

Ham Academy Lesson: 3A

Extra Class Questions valid thru 06-30-2016  
Emergency Amateur Radio Club - [www.earchi.org/education](http://www.earchi.org/education)

E6A16

**What are the majority charge carriers in N-type semiconductor material?**

- A. Holes
- B. Free electrons
- C. Free protons
- D. Free neutrons

E6A16

**B. Free electrons**

ARRL Extra Manual: Page 5-3

Ham Academy Lesson: 3A

Extra Class Questions valid thru 06-30-2016  
Emergency Amateur Radio Club - [www.earchi.org/education](http://www.earchi.org/education)

E6B02

**What is an important characteristic of a Schottky diode as compared to an ordinary silicon diode when used as a power supply rectifier?**

- A. Much higher reverse voltage breakdown
- B. Controlled reverse avalanche voltage
- C. Enhanced carrier retention time
- D. Less forward voltage drop

E6B02

**D. Less forward voltage drop**

ARRL Extra Manual: Page 5-5

Ham Academy Lesson: 3A

Extra Class Questions valid thru 06-30-2016  
Emergency Amateur Radio Club - [www.earchi.org/education](http://www.earchi.org/education)

E6B07

**What is the failure mechanism when a junction diode fails due to excessive current?**

- A. Excessive inverse voltage
- B. Excessive junction temperature
- C. Insufficient forward voltage
- D. Charge carrier depletion

E6B07

**B. Excessive junction temperature**

ARRL Extra Manual: Page 5-5

Ham Academy Lesson: 3A

Extra Class Questions valid thru 06-30-2016  
Emergency Amateur Radio Club - [www.earchi.org/education](http://www.earchi.org/education)

E6B08

**Which of the following describes a type of semiconductor diode?**

- A. Metal-semiconductor junction
- B. Electrolytic rectifier
- C. CMOS-field effect
- D. Thermionic emission diode

E6B08

**A. Metal-semiconductor junction**

ARRL Extra Manual: Page 5-5

Ham Academy Lesson: 3A

Extra Class Questions valid thru 06-30-2016  
Emergency Amateur Radio Club - [www.earchi.org/education](http://www.earchi.org/education)

E6B06

**Which of the following is a common use of a hot-carrier diode?**

- A. As balanced mixers in FM generation
- B. As a variable capacitance in an automatic frequency control circuit
- C. As a constant voltage reference in a power supply
- D. As a VHF / UHF mixer or detector

E6B06

**D. As a VHF / UHF mixer or detector**

ARRL Extra Manual: Page 5-6

Ham Academy Lesson: 3A

Extra Class Questions valid thru 06-30-2016  
Emergency Amateur Radio Club - [www.earchi.org/education](http://www.earchi.org/education)



E6B09

**What is a common use for point contact diodes?**

- A. As a constant current source
- B. As a constant voltage source
- C. As an RF detector
- D. As a high voltage rectifier

E6B09

**C. As an RF detector**

ARRL Extra Manual: Page 5-6

Ham Academy Lesson: 3A

Extra Class Questions valid thru 06-30-2016  
Emergency Amateur Radio Club - [www.earchi.org/education](http://www.earchi.org/education)

E6B01

**What is the most useful characteristic of a Zener diode?**

- A. A constant current drop under conditions of varying voltage
- B. A constant voltage drop under conditions of varying current
- C. A negative resistance region
- D. An internal capacitance that varies with the applied voltage

E6B01

**B. A constant voltage drop under conditions of varying current**

ARRL Extra Manual: Page 5-7

Ham Academy Lesson: 3A

Extra Class Questions valid thru 06-30-2016  
Emergency Amateur Radio Club - [www.earchi.org/education](http://www.earchi.org/education)

E6B03

**What special type of diode is capable of both amplification and oscillation?**

- A. Point contact
- B. Zener
- C. Tunnel
- D. Junction

E6B03

**C. Tunnel**

ARRL Extra Manual: Page 5-7

Ham Academy Lesson: 3A

Extra Class Questions valid thru 06-30-2016  
Emergency Amateur Radio Club - [www.earchi.org/education](http://www.earchi.org/education)

E6B04

**What type of semiconductor device is designed for use as a voltage-controlled capacitor?**

- A. Varactor diode
- B. Tunnel diode
- C. Silicon-controlled rectifier
- D. Zener diode

E6B04

**A. Varactor diode**

ARRL Extra Manual: Page 5-7

Ham Academy Lesson: 3A

Extra Class Questions valid thru 06-30-2016  
Emergency Amateur Radio Club - [www.earchi.org/education](http://www.earchi.org/education)

E6A07

**In Figure E6-1, what is the schematic symbol for a PNP transistor?**

- A. 1
- B. 2
- C. 4
- D. 5

E6A07

**A. 1**

ARRL Extra Manual: Page 5-8

Ham Academy Lesson: 3A

Extra Class Questions valid thru 06-30-2016  
Emergency Amateur Radio Club - [www.earchi.org/education](http://www.earchi.org/education)

E6B05

**What characteristic of a PIN diode makes it useful as an RF switch or attenuator?**

- A. Extremely high reverse breakdown voltage
- B. Ability to dissipate large amounts of power
- C. Reverse bias controls its forward voltage drop
- D. A large region of intrinsic material

E6B05

**D. A large region of intrinsic material**

ARRL Extra Manual: Page 5-8

Ham Academy Lesson: 3A

Extra Class Questions valid thru 06-30-2016  
Emergency Amateur Radio Club - [www.earchi.org/education](http://www.earchi.org/education)

E6B11

**What is used to control the attenuation of RF signals by a PIN diode?**

- A. Forward DC bias current
- B. A sub-harmonic pump signal
- C. Reverse voltage larger than the RF signal
- D. Capacitance of an RF coupling capacitor

E6B11

**A. Forward DC bias current**

ARRL Extra Manual: Page 5-8

Ham Academy Lesson: 3A

Extra Class Questions valid thru 06-30-2016  
Emergency Amateur Radio Club - [www.earchi.org/education](http://www.earchi.org/education)

E6B12

**What is one common use for PIN diodes?**

- A. As a constant current source
- B. As a constant voltage source
- C. As an RF switch
- D. As a high voltage rectifier

E6B12

**C. As an RF switch**

ARRL Extra Manual: Page 5-8

Ham Academy Lesson: 3A

Extra Class Questions valid thru 06-30-2016  
Emergency Amateur Radio Club - [www.earchi.org/education](http://www.earchi.org/education)

E6A05

**What is the alpha of a bipolar junction transistor?**

- A. The change of collector current with respect to base current
- B. The change of base current with respect to collector current
- C. The change of collector current with respect to emitter current
- D. The change of collector current with respect to gate current

E6A05

**C. The change of collector current with respect to emitter current**

ARRL Extra Manual: Page 5-9

Ham Academy Lesson: 3A

Extra Class Questions valid thru 06-30-2016  
Emergency Amateur Radio Club - [www.earchi.org/education](http://www.earchi.org/education)

E6A06

**What is the beta of a bipolar junction transistor?**

- A. The frequency at which the current gain is reduced to 1
- B. The change in collector current with respect to base current
- C. The breakdown voltage of the base to collector junction
- D. The switching speed of the transistor

E6A06

**B. The change in collector current with respect to base current**

ARRL Extra Manual: Page 5-9

Ham Academy Lesson: 3A

Extra Class Questions valid thru 06-30-2016  
Emergency Amateur Radio Club - [www.earchi.org/education](http://www.earchi.org/education)

E6A08

**What term indicates the frequency at which the grounded-base current gain of a transistor has decreased to 0.7 of the gain obtainable at 1 kHz?**

- A. Corner frequency
- B. Alpha rejection frequency
- C. Beta cutoff frequency
- D. Alpha cutoff frequency

E6A08

**D. Alpha cutoff frequency**

ARRL Extra Manual: Page 5-10

Ham Academy Lesson: 3A

Extra Class Questions valid thru 06-30-2016  
Emergency Amateur Radio Club - [www.earchi.org/education](http://www.earchi.org/education)

E6A17

**What are the names of the three terminals of a field-effect transistor?**

- A. Gate 1, gate 2, drain
- B. Emitter, base, collector
- C. Emitter, base 1, base 2
- D. Gate, drain, source

E6A17

**D. Gate, drain, source**

ARRL Extra Manual: Page 5-10

Ham Academy Lesson: 3B

Extra Class Questions valid thru 06-30-2016  
Emergency Amateur Radio Club - [www.earchi.org/education](http://www.earchi.org/education)

E6A10

**In Figure E6-2, what is the schematic symbol for an N-channel dual-gate MOSFET?**

- A. 2
- B. 4
- C. 5
- D. 6

E6A10

**B. 4**

ARRL Extra Manual: Page 5-11

Ham Academy Lesson: 3B

Extra Class Questions valid thru 06-30-2016  
Emergency Amateur Radio Club - [www.earchi.org/education](http://www.earchi.org/education)

E6A11

**In Figure E6-2, what is the schematic symbol for a P-channel junction FET?**

- A. 1
- B. 2
- C. 3
- D. 6

E6A11

**A. 1**

ARRL Extra Manual: Page 5-11

Ham Academy Lesson: 3B

Extra Class Questions valid thru 06-30-2016  
Emergency Amateur Radio Club - [www.earchi.org/education](http://www.earchi.org/education)

E6A12

**Why do many MOSFET devices have internally connected Zener diodes on the gates?**

- A. To provide a voltage reference for the correct amount of reverse-bias gate voltage
- B. To protect the substrate from excessive voltages
- C. To keep the gate voltage within specifications and prevent the device from overheating
- D. To reduce the chance of the gate insulation being punctured by static discharges or excessive voltages

E6A12

**D. To reduce the chance of the gate insulation being punctured by static discharges or excessive voltages**

ARRL Extra Manual: Page 5-11

Ham Academy Lesson: 3B

Extra Class Questions valid thru 06-30-2016  
Emergency Amateur Radio Club - [www.earchi.org/education](http://www.earchi.org/education)

E6A14

**How does DC input impedance at the gate of a field-effect transistor compare with the DC input impedance of a bipolar transistor?**

- A. They are both low impedance
- B. An FET has low input impedance; a bipolar transistor has high input impedance
- C. An FET has high input impedance; a bipolar transistor has low input impedance
- D. They are both high impedance

E6A14

**C. An FET has high input impedance; a bipolar transistor has low input impedance**

ARRL Extra Manual: Page 5-11

Ham Academy Lesson: 3B

Extra Class Questions valid thru 06-30-2016  
Emergency Amateur Radio Club - [www.earchi.org/education](http://www.earchi.org/education)

E6A09

**What is a depletion-mode FET?**

- A. An FET that exhibits a current flow between source and drain when no gate voltage is applied
- B. An FET that has no current flow between source and drain when no gate voltage is applied
- C. Any FET without a channel
- D. Any FET for which holes are the majority carriers

E6A09

**A. An FET that exhibits a current flow between source and drain when no gate voltage is applied**

ARRL Extra Manual: Page 5-12

Ham Academy Lesson: 3B

Extra Class Questions valid thru 06-30-2016  
Emergency Amateur Radio Club - [www.earchi.org/education](http://www.earchi.org/education)

E6E08

**How is power-supply voltage normally furnished to the most common type of monolithic microwave integrated circuit (MMIC)?**

- A. Through a resistor and/or RF choke connected to the amplifier output lead
- B. MMICs require no operating bias
- C. Through a capacitor and RF choke connected to the amplifier input lead
- D. Directly to the bias-voltage (VCC IN) lead

E6E08

**A. Through a resistor and/or RF choke connected to the amplifier output lead**

ARRL Extra Manual: Page 5-12

Ham Academy Lesson: 3B

Extra Class Questions valid thru 06-30-2016  
Emergency Amateur Radio Club - [www.earchi.org/education](http://www.earchi.org/education)

E6B13

**What type of bias is required for an LED to emit light?**

- A. Reverse bias
- B. Forward bias
- C. Zero bias
- D. Inductive bias

E6B13

**B. Forward bias**

ARRL Extra Manual: Page 5-13

Ham Academy Lesson: 3B

Extra Class Questions valid thru 06-30-2016  
Emergency Amateur Radio Club - [www.earchi.org/education](http://www.earchi.org/education)

E6E04

**What is the most common input and output impedance of circuits that use MMICs?**

- A. 50 ohms
- B. 300 ohms
- C. 450 ohms
- D. 10 ohms

E6E04

**A. 50 ohms**

ARRL Extra Manual: Page 5-13

Ham Academy Lesson: 3B

Extra Class Questions valid thru 06-30-2016  
Emergency Amateur Radio Club - [www.earchi.org/education](http://www.earchi.org/education)

E6E06

**What characteristics of the MMIC make it a popular choice for VHF through microwave circuits?**

- A. The ability to retrieve information from a single signal even in the presence of other strong signals.
- B. Plate current that is controlled by a control grid
- C. Nearly infinite gain, very high input impedance, and very low output impedance
- D. Controlled gain, low noise figure, and constant input and output impedance over the specified frequency range

E6E06

**D. Controlled gain, low noise figure, and constant input and output impedance over the specified frequency range**

ARRL Extra Manual: Page 5-13

Ham Academy Lesson: 3B

Extra Class Questions valid thru 06-30-2016  
Emergency Amateur Radio Club - [www.earchi.org/education](http://www.earchi.org/education)

E6E07

**Which of the following techniques is typically used to construct a MMIC-based microwave amplifier?**

- A. Ground-plane construction
- B. Microstrip construction
- C. Point-to-point construction
- D. Wave-soldering construction

E6E07

**B. Microstrip construction**

ARRL Extra Manual: Page 5-13

Ham Academy Lesson: 3B

Extra Class Questions valid thru 06-30-2016  
Emergency Amateur Radio Club - [www.earchi.org/education](http://www.earchi.org/education)

E6E11

**Which of the following materials is likely to provide the highest frequency of operation when used in MMICs?**

- A. Silicon
- B. Silicon nitride
- C. Silicon dioxide
- D. Gallium nitride

E6E11

**D. Gallium nitride**

ARRL Extra Manual: Page 5-13

Ham Academy Lesson: 3B

Extra Class Questions valid thru 06-30-2016  
Emergency Amateur Radio Club - [www.earchi.org/education](http://www.earchi.org/education)

E6B10

**In Figure E6-3, what is the schematic symbol for a light-emitting diode?**

- A. 1
- B. 5
- C. 6
- D. 7

E6B10

**B. 5**

ARRL Extra Manual: Page 5-14

Ham Academy Lesson: 3B

Extra Class Questions valid thru 06-30-2016  
Emergency Amateur Radio Club - [www.earchi.org/education](http://www.earchi.org/education)

E6D05

**What is a liquid-crystal display (LCD)?**

- A. A modern replacement for a quartz crystal oscillator which displays its fundamental frequency
- B. A display using a crystalline liquid which, in conjunction with polarizing filters, becomes opaque when voltage is applied
- C. A frequency-determining unit for a transmitter or receiver
- D. A display that uses a glowing liquid to remain brightly lit in dim light

E6D05

**B. A display using a crystalline liquid which, in conjunction with polarizing filters, becomes opaque when voltage is applied**

ARRL Extra Manual: Page 5-14

Ham Academy Lesson: 3B

Extra Class Questions valid thru 06-30-2016

Emergency Amateur Radio Club - [www.earchi.org/education](http://www.earchi.org/education)

E6D15

**What is the principle advantage of liquid-crystal display (LCD) devices over other types of display devices?**

- A. They consume less power
- B. They can display changes instantly
- C. They are visible in all light conditions
- D. They can be easily interchanged with other display devices

E6D15

**A. They consume less power**

ARRL Extra Manual: Page 5-14

Ham Academy Lesson: 3B

Extra Class Questions valid thru 06-30-2016

Emergency Amateur Radio Club - [www.earchi.org/education](http://www.earchi.org/education)

E6D13

**What type of CRT deflection is better when high-frequency waveforms are to be displayed on the screen?**

- A. Electromagnetic
- B. Tubular
- C. Radar
- D. Electrostatic

E6D13

**D. Electrostatic**

ARRL Extra Manual: Page 5-15

Ham Academy Lesson: 3B

Extra Class Questions valid thru 06-30-2016

Emergency Amateur Radio Club - [www.earchi.org/education](http://www.earchi.org/education)

E6D01

**What is cathode ray tube (CRT) persistence?**

- A. The time it takes for an image to appear after the electron beam is turned on
- B. The relative brightness of the display under varying conditions of ambient light
- C. The ability of the display to remain in focus under varying conditions
- D. The length of time the image remains on the screen after the beam is turned off

E6D01

**D. The length of time the image remains on the screen after the beam is turned off**

ARRL Extra Manual: Page 5-16

Ham Academy Lesson: 3B

Extra Class Questions valid thru 06-30-2016

Emergency Amateur Radio Club - [www.earchi.org/education](http://www.earchi.org/education)

E6D02

**Exceeding what design rating can cause a cathode ray tube (CRT) to generate X-rays?**

- A. The heater voltage
- B. The anode voltage
- C. The operating temperature
- D. The operating frequency

E6D02

**B. The anode voltage**

ARRL Extra Manual: Page 5-16

Ham Academy Lesson: 3B

Extra Class Questions valid thru 06-30-2016

Emergency Amateur Radio Club - [www.earchi.org/education](http://www.earchi.org/education)

E6D03

**Which of the following is true of a charge-coupled device (CCD)?**

- A. Its phase shift changes rapidly with frequency
- B. It is a CMOS analog-to-digital converter
- C. It samples an analog signal and passes it in stages from the input to the output
- D. It is used in a battery charger circuit

E6D03

**C. It samples an analog signal and passes it in stages from the input to the output**

ARRL Extra Manual: Page 5-16

Ham Academy Lesson: 3B

Extra Class Questions valid thru 06-30-2016

Emergency Amateur Radio Club - [www.earchi.org/education](http://www.earchi.org/education)

E6D14

**Which is NOT true of a charge-coupled device (CCD)?**

- A. It uses a combination of analog and digital circuitry
- B. It can be used to make an audio delay line
- C. It is commonly used as an analog-to-digital converter
- D. It samples and stores analog signals

E6D14

**C. It is commonly used as an analog-to-digital converter**

ARRL Extra Manual: Page 5-16

Ham Academy Lesson: 3B

Extra Class Questions valid thru 06-30-2016

Emergency Amateur Radio Club - [www.earchi.org/education](http://www.earchi.org/education)

E6D04

**What function does a charge-coupled device (CCD) serve in a modern video camera?**

- A. It stores photogenerated charges as signals corresponding to pixels
- B. It generates the horizontal pulses needed for electron beam scanning
- C. It focuses the light used to produce a pattern of electrical charges corresponding to the image
- D. It combines audio and video information to produce a composite RF signal

E6D04

**A. It stores photogenerated charges as signals corresponding to pixels**

ARRL Extra Manual: Page 5-17

Ham Academy Lesson: 3B

Extra Class Questions valid thru 06-30-2016

Emergency Amateur Radio Club - [www.earchi.org/education](http://www.earchi.org/education)



E6C11

**In Figure E6-5, what is the schematic symbol for the NOT operation (inverter)?**

- A. 2
- B. 4
- C. 5
- D. 6

E6C11

**C. 5**

ARRL Extra Manual: Page 5-18

Ham Academy Lesson: 3B

Extra Class Questions valid thru 06-30-2016  
Emergency Amateur Radio Club - [www.earchi.org/education](http://www.earchi.org/education)

E7A10

**What is a truth table?**

- A. A table of logic symbols that indicate the high logic states of an op-amp
- B. A diagram showing logic states when the digital device's output is true
- C. A list of inputs and corresponding outputs for a digital device
- D. A table of logic symbols that indicates the low logic states of an op-amp

E7A10

**C. A list of inputs and corresponding outputs for a digital device**

ARRL Extra Manual: Page 5-18

Ham Academy Lesson: 3B

Extra Class Questions valid thru 06-30-2016  
Emergency Amateur Radio Club - [www.earchi.org/education](http://www.earchi.org/education)

E6C07

**In Figure E6-5, what is the schematic symbol for an AND gate?**

- A. 1
- B. 2
- C. 3
- D. 4

E6C07

**A. 1**

ARRL Extra Manual: Page 5-19

Ham Academy Lesson: 3B

Extra Class Questions valid thru 06-30-2016  
Emergency Amateur Radio Club - [www.earchi.org/education](http://www.earchi.org/education)

E6C08

**In Figure E6-5, what is the schematic symbol for a NAND gate?**

- A. 1
- B. 2
- C. 3
- D. 4

E6C08

**B. 2**

ARRL Extra Manual: Page 5-19

Ham Academy Lesson: 3B

Extra Class Questions valid thru 06-30-2016  
Emergency Amateur Radio Club - [www.earchi.org/education](http://www.earchi.org/education)

E6C09

**In Figure E6-5, what is the schematic symbol for an OR gate?**

- A. 2
- B. 3
- C. 4
- D. 6

E6C09

**B. 3**

ARRL Extra Manual: Page 5-19

Ham Academy Lesson: 3B

Extra Class Questions valid thru 06-30-2016  
Emergency Amateur Radio Club - [www.earchi.org/education](http://www.earchi.org/education)

E6C10

**In Figure E6-5, what is the schematic symbol for a NOR gate?**

- A. 1
- B. 2
- C. 3
- D. 4

E6C10

**D. 4**

ARRL Extra Manual: Page 5-19

Ham Academy Lesson: 3B

Extra Class Questions valid thru 06-30-2016  
Emergency Amateur Radio Club - [www.earchi.org/education](http://www.earchi.org/education)

E7A07

**What logical operation does a NAND gate perform?**

- A. It produces a logic "0" at its output only when all inputs are logic "0"
- B. It produces a logic "1" at its output only when all inputs are logic "1"
- C. It produces a logic "0" at its output if some but not all of its inputs are logic "1"
- D. It produces a logic "0" at its output only when all inputs are logic "1"

E7A07

**D. It produces a logic "0" at its output only when all inputs are logic "1"**

ARRL Extra Manual: Page 5-19

Ham Academy Lesson: 3B

Extra Class Questions valid thru 06-30-2016  
Emergency Amateur Radio Club - [www.earchi.org/education](http://www.earchi.org/education)

E7A08

**What logical operation does an OR gate perform?**

- A. It produces a logic "1" at its output if any or all inputs are logic "1"
- B. It produces a logic "0" at its output if all inputs are logic "1"
- C. It only produces a logic "0" at its output when all inputs are logic "1"
- D. It produces a logic "1" at its output if all inputs are logic "0"

E7A08

**A. It produces a logic "1" at its output if any or all inputs are logic "1"**

ARRL Extra Manual: Page 5-19

Ham Academy Lesson: 3B

Extra Class Questions valid thru 06-30-2016  
Emergency Amateur Radio Club - [www.earchi.org/education](http://www.earchi.org/education)

E7A09

**What logical operation is performed by a two-input exclusive NOR gate?**

- A. It produces a logic "0" at its output only if all inputs are logic "0"
- B. It produces a logic "1" at its output only if all inputs are logic "1"
- C. It produces a logic "0" at its output if any single input is a logic "1"
- D. It produces a logic "1" at its output if any single input is a logic "1"

E7A09

**C. It produces a logic "0" at its output if any single input is a logic "1"**

ARRL Extra Manual: Page 5-19

Ham Academy Lesson: 3B

Extra Class Questions valid thru 06-30-2016  
Emergency Amateur Radio Club - [www.earchi.org/education](http://www.earchi.org/education)

E6C03

**Which of the following describes tri-state logic?**

- A. Logic devices with 0, 1, and high impedance output states
- B. Logic devices that utilize ternary math
- C. Low power logic devices designed to operate at 3 volts
- D. Proprietary logic devices manufactured by Tri-State Devices

E6C03

**A. Logic devices with 0, 1, and high impedance output states**

ARRL Extra Manual: Page 5-20

Ham Academy Lesson: 3C

Extra Class Questions valid thru 06-30-2016  
Emergency Amateur Radio Club - [www.earchi.org/education](http://www.earchi.org/education)

E6C04

**Which of the following is the primary advantage of tri-state logic?**

- A. Low power consumption
- B. Ability to connect many device outputs to a common bus
- C. High speed operation
- D. More efficient arithmetic operations

E6C04

**B. Ability to connect many device outputs to a common bus**

ARRL Extra Manual: Page 5-20

Ham Academy Lesson: 3C

Extra Class Questions valid thru 06-30-2016  
Emergency Amateur Radio Club - [www.earchi.org/education](http://www.earchi.org/education)

E7A11

**What is the name for logic which represents a logic "1" as a high voltage?**

- A. Reverse Logic
- B. Assertive Logic
- C. Negative logic
- D. Positive Logic

E7A11

**D. Positive Logic**

ARRL Extra Manual: Page 5-20

Ham Academy Lesson: 3C

Extra Class Questions valid thru 06-30-2016  
Emergency Amateur Radio Club - [www.earchi.org/education](http://www.earchi.org/education)

E7A12

**What is the name for logic which represents a logic "0" as a high voltage?**

- A. Reverse Logic
- B. Assertive Logic
- C. Negative logic
- D. Positive Logic

E7A12

**C. Negative logic**

ARRL Extra Manual: Page 5-20

Ham Academy Lesson: 3C

Extra Class Questions valid thru 06-30-2016  
Emergency Amateur Radio Club - [www.earchi.org/education](http://www.earchi.org/education)

E7A01

**Which of the following is a bistable circuit?**

- A. An "AND" gate
- B. An "OR" gate
- C. A flip-flop
- D. A clock

E7A01

**C. A flip-flop**

ARRL Extra Manual: Page 5-21

Ham Academy Lesson: 3C

Extra Class Questions valid thru 06-30-2016  
Emergency Amateur Radio Club - [www.earchi.org/education](http://www.earchi.org/education)

E7A02

**How many output level changes are obtained for every two trigger pulses applied to the input of a T flip-flop circuit?**

- A. None
- B. One
- C. Two
- D. Four

E7A02

**C. Two**

ARRL Extra Manual: Page 5-23

Ham Academy Lesson: 3C

Extra Class Questions valid thru 06-30-2016  
Emergency Amateur Radio Club - [www.earchi.org/education](http://www.earchi.org/education)

E7A13

**What is an SR or RS flip-flop?**

- A. A speed-reduced logic device with high power capability
- B. A set/reset flip-flop whose output is low when R is high and S is low, high when S is high and R is low, and unchanged when both inputs are low
- C. A speed-reduced logic device with very low voltage operation capability
- D. A set/reset flip-flop that toggles whenever the T input is pulsed, unless both inputs are high

E7A13

**B. A set/reset flip-flop whose output is low when R is high and S is low, high when S is high and R is low, and unchanged when both inputs are low**

ARRL Extra Manual: Page 5-23

Ham Academy Lesson: 3C

Extra Class Questions valid thru 06-30-2016  
Emergency Amateur Radio Club - [www.earchi.org/education](http://www.earchi.org/education)

E7A15

**What is a D flip-flop?**

- A. A flip-flop whose output takes on the state of the D input when the clock signal transitions from low to high
- B. A differential class D amplifier used as a flip-flop circuit
- C. A dynamic memory storage element
- D. A flip-flop whose output is capable of both positive and negative voltage excursions

E7A15

**A. A flip-flop whose output takes on the state of the D input when the clock signal transitions from low to high**

ARRL Extra Manual: Page 5-23

Ham Academy Lesson: 3C

Extra Class Questions valid thru 06-30-2016  
Emergency Amateur Radio Club - [www.earchi.org/education](http://www.earchi.org/education)

E7A03

**Which of the following can divide the frequency of a pulse train by 2?**

- A. An XOR gate
- B. A flip-flop
- C. An OR gate
- D. A multiplexer

E7A03

**B. A flip-flop**

ARRL Extra Manual: Page 5-24

Ham Academy Lesson: 3C

Extra Class Questions valid thru 06-30-2016  
Emergency Amateur Radio Club - [www.earchi.org/education](http://www.earchi.org/education)

E7A04

**How many flip-flops are required to divide a signal frequency by 4?**

- A. 1
- B. 2
- C. 4
- D. 8

E7A04

**B. 2**

ARRL Extra Manual: Page 5-24

Ham Academy Lesson: 3C

Extra Class Questions valid thru 06-30-2016  
Emergency Amateur Radio Club - [www.earchi.org/education](http://www.earchi.org/education)

E7A05

**Which of the following is a circuit that continuously alternates between two states without an external clock?**

- A. Monostable multivibrator
- B. J-K flip-flop
- C. T flip-flop
- D. Astable multivibrator

E7A05

**D. Astable multivibrator**

ARRL Extra Manual: Page 5-24

Ham Academy Lesson: 3C

Extra Class Questions valid thru 06-30-2016  
Emergency Amateur Radio Club - [www.earchi.org/education](http://www.earchi.org/education)

E7A06

**What is a characteristic of a monostable multivibrator?**

- A. It switches momentarily to the opposite binary state and then returns, after a set time, to its original state
- B. It is a clock that produces a continuous square wave oscillating between 1 and 0
- C. It stores one bit of data in either a 0 or 1 state
- D. It maintains a constant output voltage, regardless of variations in the input voltage

E7A06

**A. It switches momentarily to the opposite binary state and then returns, after a set time, to its original state**

ARRL Extra Manual: Page 5-24

Ham Academy Lesson: 3C

Extra Class Questions valid thru 06-30-2016

Emergency Amateur Radio Club - [www.earchi.org/education](http://www.earchi.org/education)

E7A14

**What is a JK flip-flop?**

- A. A flip-flop similar to an RS except that it toggles when both J and K are high
- B. A flip-flop utilizing low power, low temperature Joule-Kelvin devices
- C. A flip-flop similar to a D flip-flop except that it triggers on the negative clock edge
- D. A flip-flop originally developed in Japan and Korea which has very low power consumption

E7A14

**A. A flip-flop similar to an RS except that it toggles when both J and K are high**

ARRL Extra Manual: Page 5-24

Ham Academy Lesson: 3C

Extra Class Questions valid thru 06-30-2016

Emergency Amateur Radio Club - [www.earchi.org/education](http://www.earchi.org/education)

E7F01

**What is the purpose of a prescaler circuit?**

- A. It converts the output of a JK flip flop to that of an RS flip-flop
- B. It multiplies a higher frequency signal so a low-frequency counter can display the operating frequency
- C. It prevents oscillation in a low-frequency counter circuit
- D. It divides a higher frequency signal so a low-frequency counter can display the input frequency

E7F01

**D. It divides a higher frequency signal so a low-frequency counter can display the input frequency**

ARRL Extra Manual: Page 5-25

Ham Academy Lesson: 3C

Extra Class Questions valid thru 06-30-2016

Emergency Amateur Radio Club - [www.earchi.org/education](http://www.earchi.org/education)

E7F02

**Which of the following would be used to reduce a signal's frequency by a factor of ten?**

- A. A preamp
- B. A prescaler
- C. A marker generator
- D. A flip-flop

E7F02

**B. A prescaler**

ARRL Extra Manual: Page 5-25

Ham Academy Lesson: 3C

Extra Class Questions valid thru 06-30-2016

Emergency Amateur Radio Club - [www.earchi.org/education](http://www.earchi.org/education)

E7F03

**What is the function of a decade counter digital IC?**

- A. It produces one output pulse for every ten input pulses
- B. It decodes a decimal number for display on a seven-segment LED display
- C. It produces ten output pulses for every input pulse
- D. It adds two decimal numbers together

E7F03

**A. It produces one output pulse for every ten input pulses**

ARRL Extra Manual: Page 5-25

Ham Academy Lesson: 3D

Extra Class Questions valid thru 06-30-2016  
Emergency Amateur Radio Club - [www.earchi.org/education](http://www.earchi.org/education)

E7F07

**What determines the accuracy of a frequency counter?**

- A. The accuracy of the time base
- B. The speed of the logic devices used
- C. Accuracy of the AC input frequency to the power supply
- D. Proper balancing of the mixer diodes

E7F07

**A. The accuracy of the time base**

ARRL Extra Manual: Page 5-25

Ham Academy Lesson: 3D

Extra Class Questions valid thru 06-30-2016  
Emergency Amateur Radio Club - [www.earchi.org/education](http://www.earchi.org/education)

E7F08

**Which of the following is performed by a frequency counter?**

- A. Determining the frequency deviation with an FM discriminator
- B. Mixing the incoming signal with a WWV reference
- C. Counting the number of input pulses occurring within a specific period of time
- D. Converting the phase of the measured signal to a voltage which is proportional to the frequency

E7F08

**C. Counting the number of input pulses occurring within a specific period of time**

ARRL Extra Manual: Page 5-25

Ham Academy Lesson: 3D

Extra Class Questions valid thru 06-30-2016  
Emergency Amateur Radio Club - [www.earchi.org/education](http://www.earchi.org/education)

E7F09

**What is the purpose of a frequency counter?**

- A. To provide a digital representation of the frequency of a signal
- B. To generate a series of reference signals at known frequency intervals
- C. To display all frequency components of a transmitted signal
- D. To provide a signal source at a very accurate frequency

E7F09

**A. To provide a digital representation of the frequency of a signal**

ARRL Extra Manual: Page 5-25

Ham Academy Lesson: 3D

Extra Class Questions valid thru 06-30-2016  
Emergency Amateur Radio Club - [www.earchi.org/education](http://www.earchi.org/education)

E7F04

**What additional circuitry must be added to a 100-kHz crystal-controlled marker generator so as to provide markers at 50 and 25 kHz?**

- A. An emitter-follower
- B. Two frequency multipliers
- C. Two flip-flops
- D. A voltage divider

E7F04

**C. Two flip-flops**

ARRL Extra Manual: Page 5-26

Ham Academy Lesson: 3D

Extra Class Questions valid thru 06-30-2016  
Emergency Amateur Radio Club - [www.earchi.org/education](http://www.earchi.org/education)

E7F05

**Which of the following is a technique for providing high stability oscillators needed for microwave transmission and reception?**

- A. Use a GPS signal reference
- B. Use a rubidium stabilized reference oscillator
- C. Use a temperature-controlled high Q dielectric resonator
- D. All of these choices are correct

E7F05

**D. All of these choices are correct**

ARRL Extra Manual: Page 5-26

Ham Academy Lesson: 3D

Extra Class Questions valid thru 06-30-2016  
Emergency Amateur Radio Club - [www.earchi.org/education](http://www.earchi.org/education)

E7F06

**What is one purpose of a marker generator?**

- A. To add audio markers to an oscilloscope
- B. To provide a frequency reference for a phase locked loop
- C. To provide a means of calibrating a receiver's frequency settings
- D. To add time signals to a transmitted signal

E7F06

**C. To provide a means of calibrating a receiver's frequency settings**

ARRL Extra Manual: Page 5-26

Ham Academy Lesson: 3D

Extra Class Questions valid thru 06-30-2016  
Emergency Amateur Radio Club - [www.earchi.org/education](http://www.earchi.org/education)

E7F10

**What alternate method of determining frequency, other than by directly counting input pulses, is used by some counters?**

- A. GPS averaging
- B. Period measurement plus mathematical computation
- C. Prescaling
- D. D/A conversion

E7F10

**B. Period measurement plus mathematical computation**

ARRL Extra Manual: Page 5-26

Ham Academy Lesson: 3D

Extra Class Questions valid thru 06-30-2016  
Emergency Amateur Radio Club - [www.earchi.org/education](http://www.earchi.org/education)



E7F11

**What is an advantage of a period-measuring frequency counter over a direct-count type?**

- A. It can run on battery power for remote measurements
- B. It does not require an expensive high-precision time base
- C. It provides improved resolution of low-frequency signals within a comparable time period
- D. It can directly measure the modulation index of an FM transmitter

E7F11

**C. It provides improved resolution of low-frequency signals within a comparable time period**

ARRL Extra Manual: Page 5-26

Ham Academy Lesson: 3D

Extra Class Questions valid thru 06-30-2016  
Emergency Amateur Radio Club - [www.earchi.org/education](http://www.earchi.org/education)

E6A13

**What do the initials CMOS stand for?**

- A. Common Mode Oscillating System
- B. Complementary Mica-Oxide Silicon
- C. Complementary Metal-Oxide Semiconductor
- D. Common Mode Organic Silicon

E6A13

**C. Complementary Metal-Oxide Semiconductor**

ARRL Extra Manual: Page 5-28

Ham Academy Lesson: 3D

Extra Class Questions valid thru 06-30-2016  
Emergency Amateur Radio Club - [www.earchi.org/education](http://www.earchi.org/education)

E6C01

**What is the recommended power supply voltage for TTL series integrated circuits?**

- A. 12 volts
- B. 1.5 volts
- C. 5 volts
- D. 13.6 volts

E6C01

**C. 5 volts**

ARRL Extra Manual: Page 5-28

Ham Academy Lesson: 3D

Extra Class Questions valid thru 06-30-2016  
Emergency Amateur Radio Club - [www.earchi.org/education](http://www.earchi.org/education)

E6C02

**What logic state do the inputs of a TTL device assume if they are left open?**

- A. A logic-high state
- B. A logic-low state
- C. The device becomes randomized and will not provide consistent high or low-logic states
- D. Open inputs on a TTL device are ignored

E6C02

**A. A logic-high state**

ARRL Extra Manual: Page 5-28

Ham Academy Lesson: 3D

Extra Class Questions valid thru 06-30-2016  
Emergency Amateur Radio Club - [www.earchi.org/education](http://www.earchi.org/education)

E6C05

**Which of the following is an advantage of CMOS logic devices over TTL devices?**

- A. Differential output capability
- B. Lower distortion
- C. Immune to damage from static discharge
- D. Lower power consumption

E6C05

**D. Lower power consumption**

ARRL Extra Manual: Page 5-28

Ham Academy Lesson: 3D

Extra Class Questions valid thru 06-30-2016  
Emergency Amateur Radio Club - [www.earchi.org/education](http://www.earchi.org/education)

E6C06

**Why do CMOS digital integrated circuits have high immunity to noise on the input signal or power supply?**

- A. Larger bypass capacitors are used in CMOS circuit design
- B. The input switching threshold is about two times the power supply voltage
- C. The input switching threshold is about one-half the power supply voltage
- D. Input signals are stronger

E6C06

**C. The input switching threshold is about one-half the power supply voltage**

ARRL Extra Manual: Page 5-29

Ham Academy Lesson: 3D

Extra Class Questions valid thru 06-30-2016  
Emergency Amateur Radio Club - [www.earchi.org/education](http://www.earchi.org/education)

E6C12

**What is BiCMOS logic?**

- A. A logic device with two CMOS circuits per package
- B. An FET logic family based on bimetallic semiconductors
- C. A logic family based on bismuth CMOS devices
- D. An integrated circuit logic family using both bipolar and CMOS transistors

E6C12

**D. An integrated circuit logic family using both bipolar and CMOS transistors**

ARRL Extra Manual: Page 5-29

Ham Academy Lesson: 3D

Extra Class Questions valid thru 06-30-2016  
Emergency Amateur Radio Club - [www.earchi.org/education](http://www.earchi.org/education)

E6C13

**Which of the following is an advantage of BiCMOS logic?**

- A. Its simplicity results in much less expensive devices than standard CMOS
- B. It is totally immune to electrostatic damage
- C. It has the high input impedance of CMOS and the low output impedance of bipolar transistors
- D. All of these choices are correct

E6C13

**C. It has the high input impedance of CMOS and the low output impedance of bipolar transistors**

ARRL Extra Manual: Page 5-29

Ham Academy Lesson: 3D

Extra Class Questions valid thru 06-30-2016  
Emergency Amateur Radio Club - [www.earchi.org/education](http://www.earchi.org/education)

E6F01

**What is photoconductivity?**

- A. The conversion of photon energy to electromotive energy
- B. The increased conductivity of an illuminated semiconductor
- C. The conversion of electromotive energy to photon energy
- D. The decreased conductivity of an illuminated semiconductor

E6F01

**B. The increased conductivity of an illuminated semiconductor**

ARRL Extra Manual: Page 5-31

Ham Academy Lesson: 3D

Extra Class Questions valid thru 06-30-2016  
Emergency Amateur Radio Club - [www.earchi.org/education](http://www.earchi.org/education)

E6F02

**What happens to the conductivity of a photoconductive material when light shines on it?**

- A. It increases
- B. It decreases
- C. It stays the same
- D. It becomes unstable

E6F02

**A. It increases**

ARRL Extra Manual: Page 5-31

Ham Academy Lesson: 3D

Extra Class Questions valid thru 06-30-2016  
Emergency Amateur Radio Club - [www.earchi.org/education](http://www.earchi.org/education)

E6F06

**Which of these materials is affected the most by photoconductivity?**

- A. A crystalline semiconductor
- B. An ordinary metal
- C. A heavy metal
- D. A liquid semiconductor

E6F06

**A. A crystalline semiconductor**

ARRL Extra Manual: Page 5-31

Ham Academy Lesson: 3D

Extra Class Questions valid thru 06-30-2016  
Emergency Amateur Radio Club - [www.earchi.org/education](http://www.earchi.org/education)

E6F03

**What is the most common configuration of an optoisolator or optocoupler?**

- A. A lens and a photomultiplier
- B. A frequency modulated helium-neon laser
- C. An amplitude modulated helium-neon laser
- D. An LED and a phototransistor

E6F03

**D. An LED and a phototransistor**

ARRL Extra Manual: Page 5-32

Ham Academy Lesson: 3D

Extra Class Questions valid thru 06-30-2016  
Emergency Amateur Radio Club - [www.earchi.org/education](http://www.earchi.org/education)

E6F05

**Which of the following describes an optical shaft encoder?**

- A. A device which detects rotation of a control by interrupting a light source with a patterned wheel
- B. A device which measures the strength a beam of light using analog to digital conversion
- C. A digital encryption device often used to encrypt spacecraft control signals
- D. A device for generating RTTY signals by means of a rotating light source.

E6F05

**A. A device which detects rotation of a control by interrupting a light source with a patterned wheel**

ARRL Extra Manual: Page 5-32

Ham Academy Lesson: 3D

Extra Class Questions valid thru 06-30-2016  
Emergency Amateur Radio Club - [www.earchi.org/education](http://www.earchi.org/education)

E6F07

**What is a solid state relay?**

- A. A relay using transistors to drive the relay coil
- B. A device that uses semiconductor devices to implement the functions of an electromechanical relay
- C. A mechanical relay that latches in the on or off state each time it is pulsed
- D. A passive delay line

E6F07

**B. A device that uses semiconductor devices to implement the functions of an electromechanical relay**

ARRL Extra Manual: Page 5-32

Ham Academy Lesson: 3D

Extra Class Questions valid thru 06-30-2016  
Emergency Amateur Radio Club - [www.earchi.org/education](http://www.earchi.org/education)

E6F08

**Why are optoisolators often used in conjunction with solid state circuits when switching 120 VAC?**

- A. Optoisolators provide a low impedance link between a control circuit and a power circuit
- B. Optoisolators provide impedance matching between the control circuit and power circuit
- C. Optoisolators provide a very high degree of electrical isolation between a control circuit and the circuit being switched
- D. Optoisolators eliminate the effects of reflected light in the control circuit

E6F08

**C. Optoisolators provide a very high degree of electrical isolation between a control circuit and the circuit being switched**

ARRL Extra Manual: Page 5-32

Ham Academy Lesson: 3D

Extra Class Questions valid thru 06-30-2016  
Emergency Amateur Radio Club - [www.earchi.org/education](http://www.earchi.org/education)

E6F04

**What is the photovoltaic effect?**

- A. The conversion of voltage to current when exposed to light
- B. The conversion of light to electrical energy
- C. The conversion of electrical energy to mechanical energy
- D. The tendency of a battery to discharge when used outside

E6F04

**B. The conversion of light to electrical energy**

ARRL Extra Manual: Page 5-33

Ham Academy Lesson: 3D

Extra Class Questions valid thru 06-30-2016  
Emergency Amateur Radio Club - [www.earchi.org/education](http://www.earchi.org/education)

E6F09

**What is the efficiency of a photovoltaic cell?**

- A. The output RF power divided by the input dc power
- B. The effective payback period
- C. The open-circuit voltage divided by the short-circuit current under full illumination
- D. The relative fraction of light that is converted to current

E6F09

**D. The relative fraction of light that is converted to current**

ARRL Extra Manual: Page 5-33

Ham Academy Lesson: 3D

Extra Class Questions valid thru 06-30-2016  
Emergency Amateur Radio Club - [www.earchi.org/education](http://www.earchi.org/education)

E6F10

**What is the most common type of photovoltaic cell used for electrical power generation?**

- A. Selenium
- B. Silicon
- C. Cadmium Sulfide
- D. Copper oxide

E6F10

**B. Silicon**

ARRL Extra Manual: Page 5-33

Ham Academy Lesson: 3D

Extra Class Questions valid thru 06-30-2016  
Emergency Amateur Radio Club - [www.earchi.org/education](http://www.earchi.org/education)

E6F11

**Which of the following is the approximate open-circuit voltage produced by a fully-illuminated silicon photovoltaic cell?**

- A. 0.1 V
- B. 0.5 V
- C. 1.5 V
- D. 12 V

E6F11

**B. 0.5 V**

ARRL Extra Manual: Page 5-33

Ham Academy Lesson: 3D

Extra Class Questions valid thru 06-30-2016  
Emergency Amateur Radio Club - [www.earchi.org/education](http://www.earchi.org/education)

E6F12

**What absorbs the energy from light falling on a photovoltaic cell?**

- A. Protons
- B. Photons
- C. Electrons
- D. Holes

E6F12

**C. Electrons**

ARRL Extra Manual: Page 5-33

Ham Academy Lesson: 3D

Extra Class Questions valid thru 06-30-2016  
Emergency Amateur Radio Club - [www.earchi.org/education](http://www.earchi.org/education)

E7B10

**In Figure E7-1, what is the purpose of R1 and R2?**

- A. Load resistors
- B. Fixed bias
- C. Self bias
- D. Feedback

E7B10

**B. Fixed bias**

ARRL Extra Manual: Page 6-3

Ham Academy Lesson: 4A

Extra Class Questions valid thru 06-30-2016  
Emergency Amateur Radio Club - [www.earchi.org/education](http://www.earchi.org/education)

E7B11

**In Figure E7-1, what is the purpose of R3?**

- A. Fixed bias
- B. Emitter bypass
- C. Output load resistor
- D. Self bias

E7B11

**D. Self bias**

ARRL Extra Manual: Page 6-3

Ham Academy Lesson: 4A

Extra Class Questions valid thru 06-30-2016  
Emergency Amateur Radio Club - [www.earchi.org/education](http://www.earchi.org/education)

E7B12

**What type of circuit is shown in Figure E7-1?**

- A. Switching voltage regulator
- B. Linear voltage regulator
- C. Common emitter amplifier
- D. Emitter follower amplifier

E7B12

**C. Common emitter amplifier**

ARRL Extra Manual: Page 6-3

Ham Academy Lesson: 4A

Extra Class Questions valid thru 06-30-2016  
Emergency Amateur Radio Club - [www.earchi.org/education](http://www.earchi.org/education)

E7B15

**What is one way to prevent thermal runaway in a bipolar transistor amplifier?**

- A. Neutralization
- B. Select transistors with high beta
- C. Use a resistor in series with the emitter
- D. All of these choices are correct

E7B15

**C. Use a resistor in series with the emitter**

ARRL Extra Manual: Page 6-3

Ham Academy Lesson: 4A

Extra Class Questions valid thru 06-30-2016  
Emergency Amateur Radio Club - [www.earchi.org/education](http://www.earchi.org/education)

E7B13

**In Figure E7-2, what is the purpose of R?**

- A. Emitter load
- B. Fixed bias
- C. Collector load
- D. Voltage regulation

E7B13

**A. Emitter load**

ARRL Extra Manual: Page 6-5

Ham Academy Lesson: 4A

Extra Class Questions valid thru 06-30-2016  
Emergency Amateur Radio Club - [www.earchi.org/education](http://www.earchi.org/education)

E7B14

**In Figure E7-2, what is the purpose of C2?**

- A. Output coupling
- B. Emitter bypass
- C. Input coupling
- D. Hum filtering

E7B14

**A. Output coupling**

ARRL Extra Manual: Page 6-5

Ham Academy Lesson: 4A

Extra Class Questions valid thru 06-30-2016  
Emergency Amateur Radio Club - [www.earchi.org/education](http://www.earchi.org/education)

E7B18

**Which of the following is a characteristic of a grounded-grid amplifier?**

- A. High power gain
- B. High filament voltage
- C. Low input impedance
- D. Low bandwidth

E7B18

**C. Low input impedance**

ARRL Extra Manual: Page 6-6

Ham Academy Lesson: 4A

Extra Class Questions valid thru 06-30-2016  
Emergency Amateur Radio Club - [www.earchi.org/education](http://www.earchi.org/education)

E7G12

**What is an integrated circuit operational amplifier?**

- A. A high-gain, direct-coupled differential amplifier with very high input and very low output impedance
- B. A digital audio amplifier whose characteristics are determined by components external to the amplifier
- C. An amplifier used to increase the average output of frequency modulated amateur signals to the legal limit
- D. An RF amplifier used in the UHF and microwave regions

E7G12

**A. A high-gain, direct-coupled differential amplifier with very high input and very low output impedance**

ARRL Extra Manual: Page 6-6

Ham Academy Lesson: 4A

Extra Class Questions valid thru 06-30-2016  
Emergency Amateur Radio Club - [www.earchi.org/education](http://www.earchi.org/education)

E7G08

**How does the gain of an ideal operational amplifier vary with frequency?**

- A. It increases linearly with increasing frequency
- B. It decreases linearly with increasing frequency
- C. It decreases logarithmically with increasing frequency
- D. It does not vary with frequency

E7G08

**D. It does not vary with frequency**

ARRL Extra Manual: Page 6-7

Ham Academy Lesson: 4A

Extra Class Questions valid thru 06-30-2016  
Emergency Amateur Radio Club - [www.earchi.org/education](http://www.earchi.org/education)

E7G14

**What is the typical input impedance of an integrated circuit op-amp?**

- A. 100 ohms
- B. 1000 ohms
- C. Very low
- D. Very high

E7G14

**D. Very high**

ARRL Extra Manual: Page 6-7

Ham Academy Lesson: 4A

Extra Class Questions valid thru 06-30-2016  
Emergency Amateur Radio Club - [www.earchi.org/education](http://www.earchi.org/education)

E7G15

**What is the typical output impedance of an integrated circuit op-amp?**

- A. Very low
- B. Very high
- C. 100 ohms
- D. 1000 ohms

E7G15

**A. Very low**

ARRL Extra Manual: Page 6-7

Ham Academy Lesson: 4A

Extra Class Questions valid thru 06-30-2016  
Emergency Amateur Radio Club - [www.earchi.org/education](http://www.earchi.org/education)

E7G13

**What is meant by the term op-amp input-offset voltage?**

- A. The output voltage of the op-amp minus its input voltage
- B. The differential input voltage needed to bring the open-loop output voltage to zero
- C. The input voltage needed to bring the open-loop output voltage to zero
- D. The potential between the amplifier input terminals of the op-amp in an open-loop condition

E7G13

**C. The input voltage needed to bring the open-loop output voltage to zero**

ARRL Extra Manual: Page 6-8

Ham Academy Lesson: 4A

Extra Class Questions valid thru 06-30-2016  
Emergency Amateur Radio Club - [www.earchi.org/education](http://www.earchi.org/education)



E7G07

**What magnitude of voltage gain can be expected from the circuit in Figure E7-4 when R1 is 10 ohms and RF is 470 ohms?**

- A. 0.21
- B. 94
- C. 47
- D. 24

E7G07

**C. 47**

ARRL Extra Manual: Page 6-9

Ham Academy Lesson: 4A

Extra Class Questions valid thru 06-30-2016  
Emergency Amateur Radio Club - [www.earchi.org/education](http://www.earchi.org/education)

E7G09

**What will be the output voltage of the circuit shown in Figure E7-4 if R1 is 1000 ohms, RF is 10,000 ohms, and 0.23 volts dc is applied to the input?**

- A. 0.23 volts
- B. 2.3 volts
- C. -0.23 volts
- D. -2.3 volts

E7G09

**D. -2.3 volts**

ARRL Extra Manual: Page 6-9

Ham Academy Lesson: 4A

Extra Class Questions valid thru 06-30-2016  
Emergency Amateur Radio Club - [www.earchi.org/education](http://www.earchi.org/education)

E7G10

**What absolute voltage gain can be expected from the circuit in Figure E7-4 when R1 is 1800 ohms and RF is 68 kilohms?**

- A. 1
- B. 0.03
- C. 38
- D. 76

E7G10

**C. 38**

ARRL Extra Manual: Page 6-9

Ham Academy Lesson: 4A

Extra Class Questions valid thru 06-30-2016  
Emergency Amateur Radio Club - [www.earchi.org/education](http://www.earchi.org/education)

E7G11

**What absolute voltage gain can be expected from the circuit in Figure E7-4 when R1 is 3300 ohms and RF is 47 kilohms?**

- A. 28
- B. 14
- C. 7
- D. 0.07

E7G11

**B. 14**

ARRL Extra Manual: Page 6-9

Ham Academy Lesson: 4A

Extra Class Questions valid thru 06-30-2016  
Emergency Amateur Radio Club - [www.earchi.org/education](http://www.earchi.org/education)

E7B01

**For what portion of a signal cycle does a Class AB amplifier operate?**

- A. More than 180 degrees but less than 360 degrees
- B. Exactly 180 degrees
- C. The entire cycle
- D. Less than 180 degrees

E7B01

**A. More than 180 degrees but less than 360 degrees**

ARRL Extra Manual: Page 6-11

Ham Academy Lesson: 4A

Extra Class Questions valid thru 06-30-2016  
Emergency Amateur Radio Club - [www.earchi.org/education](http://www.earchi.org/education)

E7B04

**Where on the load line of a Class A common emitter amplifier would bias normally be set?**

- A. Approximately half-way between saturation and cutoff
- B. Where the load line intersects the voltage axis
- C. At a point where the bias resistor equals the load resistor
- D. At a point where the load line intersects the zero bias current curve

E7B04

**A. Approximately half-way between saturation and cutoff**

ARRL Extra Manual: Page 6-11

Ham Academy Lesson: 4A

Extra Class Questions valid thru 06-30-2016  
Emergency Amateur Radio Club - [www.earchi.org/education](http://www.earchi.org/education)

E7B02

**What is a Class D amplifier?**

- A. A type of amplifier that uses switching technology to achieve high efficiency
- B. A low power amplifier using a differential amplifier for improved linearity
- C. An amplifier using drift-mode FETs for high efficiency
- D. A frequency doubling amplifier

E7B02

**A. A type of amplifier that uses switching technology to achieve high efficiency**

ARRL Extra Manual: Page 6-12

Ham Academy Lesson: 4A

Extra Class Questions valid thru 06-30-2016  
Emergency Amateur Radio Club - [www.earchi.org/education](http://www.earchi.org/education)

E7B03

**Which of the following forms the output of a class D amplifier circuit?**

- A. A low-pass filter to remove switching signal components
- B. A high-pass filter to compensate for low gain at low frequencies
- C. A matched load resistor to prevent damage by switching transients
- D. A temperature-compensated load resistor to improve linearity

E7B03

**A. A low-pass filter to remove switching signal components**

ARRL Extra Manual: Page 6-12

Ham Academy Lesson: 4A

Extra Class Questions valid thru 06-30-2016  
Emergency Amateur Radio Club - [www.earchi.org/education](http://www.earchi.org/education)

E7B16

**What is the effect of intermodulation products in a linear power amplifier?**

- A. Transmission of spurious signals
- B. Creation of parasitic oscillations
- C. Low efficiency
- D. All of these choices are correct

E7B16

**A. Transmission of spurious signals**

ARRL Extra Manual: Page 6-12

Ham Academy Lesson: 4B

Extra Class Questions valid thru 06-30-2016  
Emergency Amateur Radio Club - [www.earchi.org/education](http://www.earchi.org/education)

E7B17

**Why are third-order intermodulation distortion products of particular concern in linear power amplifiers?**

- A. Because they are relatively close in frequency to the desired signal
- B. Because they are relatively far in frequency from the desired signal
- C. Because they invert the sidebands causing distortion
- D. Because they maintain the sidebands, thus causing multiple duplicate signals

E7B17

**A. Because they are relatively close in frequency to the desired signal**

ARRL Extra Manual: Page 6-12

Ham Academy Lesson: 4B

Extra Class Questions valid thru 06-30-2016  
Emergency Amateur Radio Club - [www.earchi.org/education](http://www.earchi.org/education)

E7B06

**Which of the following amplifier types reduces or eliminates even-order harmonics?**

- A. Push-push
- B. Push-pull
- C. Class C
- D. Class AB

E7B06

**B. Push-pull**

ARRL Extra Manual: Page 6-13

Ham Academy Lesson: 4B

Extra Class Questions valid thru 06-30-2016  
Emergency Amateur Radio Club - [www.earchi.org/education](http://www.earchi.org/education)

E7B07

**Which of the following is a likely result when a Class C amplifier is used to amplify a single-sideband phone signal?**

- A. Reduced intermodulation products
- B. Increased overall intelligibility
- C. Signal inversion
- D. Signal distortion and excessive bandwidth

E7B07

**D. Signal distortion and excessive bandwidth**

ARRL Extra Manual: Page 6-13

Ham Academy Lesson: 4B

Extra Class Questions valid thru 06-30-2016  
Emergency Amateur Radio Club - [www.earchi.org/education](http://www.earchi.org/education)

E7B05

**What can be done to prevent unwanted oscillations in an RF power amplifier?**

- A. Tune the stage for maximum SWR
- B. Tune both the input and output for maximum power
- C. Install parasitic suppressors and/or neutralize the stage
- D. Use a phase inverter in the output filter

E7B05

**C. Install parasitic suppressors and/or neutralize the stage**

ARRL Extra Manual: Page 6-14

Ham Academy Lesson: 4B

Extra Class Questions valid thru 06-30-2016  
Emergency Amateur Radio Club - [www.earchi.org/education](http://www.earchi.org/education)

E7B08

**How can an RF power amplifier be neutralized?**

- A. By increasing the driving power
- B. By reducing the driving power
- C. By feeding a 180-degree out-of-phase portion of the output back to the input
- D. By feeding an in-phase component of the output back to the input

E7B08

**C. By feeding a 180-degree out-of-phase portion of the output back to the input**

ARRL Extra Manual: Page 6-14

Ham Academy Lesson: 4B

Extra Class Questions valid thru 06-30-2016  
Emergency Amateur Radio Club - [www.earchi.org/education](http://www.earchi.org/education)

E7B19

**What is a klystron?**

- A. A high speed multivibrator
- B. An electron-coupled oscillator utilizing a pentode vacuum tube
- C. An oscillator utilizing ceramic elements to achieve stability
- D. A VHF, UHF, or microwave vacuum tube that uses velocity modulation

E7B19

**D. A VHF, UHF, or microwave vacuum tube that uses velocity modulation**

ARRL Extra Manual: Page 6-15

Ham Academy Lesson: 4B

Extra Class Questions valid thru 06-30-2016  
Emergency Amateur Radio Club - [www.earchi.org/education](http://www.earchi.org/education)

E7B20

**What is a parametric amplifier?**

- A. A type of bipolar operational amplifier with excellent linearity derived from use of very high voltage on the collector
- B. A low-noise VHF or UHF amplifier relying on varying reactance for amplification
- C. A high power amplifier for HF application utilizing the Miller effect to increase gain
- D. An audio push-pull amplifier using silicon carbide transistors for extremely low noise

E7B20

**B. A low-noise VHF or UHF amplifier relying on varying reactance for amplification**

ARRL Extra Manual: Page 6-16

Ham Academy Lesson: 4B

Extra Class Questions valid thru 06-30-2016  
Emergency Amateur Radio Club - [www.earchi.org/education](http://www.earchi.org/education)

E7B21

**Which of the following devices is generally best suited for UHF or microwave power amplifier applications?**

- A. Field effect transistor
- B. Nuvistor
- C. Silicon controlled rectifier
- D. Triac

E7B21

**A. Field effect transistor**

ARRL Extra Manual: Page 6-16

Ham Academy Lesson: 4B

Extra Class Questions valid thru 06-30-2016  
Emergency Amateur Radio Club - [www.earchi.org/education](http://www.earchi.org/education)

E7H02

**What condition must exist for a circuit to oscillate?**

- A. It must have at least two stages
- B. It must be neutralized
- C. It must have positive feedback with a gain greater than 1
- D. It must have negative feedback sufficient to cancel the input signal

E7H02

**C. It must have positive feedback with a gain greater than 1**

ARRL Extra Manual: Page 6-17

Ham Academy Lesson: 4B

Extra Class Questions valid thru 06-30-2016  
Emergency Amateur Radio Club - [www.earchi.org/education](http://www.earchi.org/education)

E7H01

**What are three oscillator circuits used in Amateur Radio equipment?**

- A. Taft, Pierce and negative feedback
- B. Pierce, Fenner and Beane
- C. Taft, Hartley and Pierce
- D. Colpitts, Hartley and Pierce

E7H01

**D. Colpitts, Hartley and Pierce**

ARRL Extra Manual: Page 6-18

Ham Academy Lesson: 4B

Extra Class Questions valid thru 06-30-2016  
Emergency Amateur Radio Club - [www.earchi.org/education](http://www.earchi.org/education)

E7H03

**How is positive feedback supplied in a Hartley oscillator?**

- A. Through a tapped coil
- B. Through a capacitive divider
- C. Through link coupling
- D. Through a neutralizing capacitor

E7H03

**A. Through a tapped coil**

ARRL Extra Manual: Page 6-18

Ham Academy Lesson: 4B

Extra Class Questions valid thru 06-30-2016  
Emergency Amateur Radio Club - [www.earchi.org/education](http://www.earchi.org/education)

E7H04

**How is positive feedback supplied in a Colpitts oscillator?**

- A. Through a tapped coil
- B. Through link coupling
- C. Through a capacitive divider
- D. Through a neutralizing capacitor

E7H04

**C. Through a capacitive divider**

ARRL Extra Manual: Page 6-18

Ham Academy Lesson: 4B

Extra Class Questions valid thru 06-30-2016  
Emergency Amateur Radio Club - [www.earchi.org/education](http://www.earchi.org/education)

E7H05

**How is positive feedback supplied in a Pierce oscillator?**

- A. Through a tapped coil
- B. Through link coupling
- C. Through a neutralizing capacitor
- D. Through a quartz crystal

E7H05

**D. Through a quartz crystal**

ARRL Extra Manual: Page 6-18

Ham Academy Lesson: 4B

Extra Class Questions valid thru 06-30-2016  
Emergency Amateur Radio Club - [www.earchi.org/education](http://www.earchi.org/education)

E6E03

**What is one aspect of the piezoelectric effect?**

- A. Physical deformation of a crystal by the application of a voltage
- B. Mechanical deformation of a crystal by the application of a magnetic field
- C. The generation of electrical energy by the application of light
- D. Reversed conduction states when a P-N junction is exposed to light

E6E03

**A. Physical deformation of a crystal by the application of a voltage**

ARRL Extra Manual: Page 6-19

Ham Academy Lesson: 4B

Extra Class Questions valid thru 06-30-2016  
Emergency Amateur Radio Club - [www.earchi.org/education](http://www.earchi.org/education)

E6E09

**Which of the following must be done to insure that a crystal oscillator provides the frequency specified by the crystal manufacturer?**

- A. Provide the crystal with a specified parallel inductance
- B. Provide the crystal with a specified parallel capacitance
- C. Bias the crystal at a specified voltage
- D. Bias the crystal at a specified current

E6E09

**B. Provide the crystal with a specified parallel capacitance**

ARRL Extra Manual: Page 6-19

Ham Academy Lesson: 4B

Extra Class Questions valid thru 06-30-2016  
Emergency Amateur Radio Club - [www.earchi.org/education](http://www.earchi.org/education)

E7H06

**Which of the following oscillator circuits are commonly used in VFOs?**

- A. Pierce and Zener
- B. Colpitts and Hartley
- C. Armstrong and deForest
- D. Negative feedback and balanced feedback

E7H06

**B. Colpitts and Hartley**

ARRL Extra Manual: Page 6-20

Ham Academy Lesson: 4B

Extra Class Questions valid thru 06-30-2016  
Emergency Amateur Radio Club - [www.earchi.org/education](http://www.earchi.org/education)

E7H07

**What is a magnetron oscillator?**

- A. An oscillator in which the output is fed back to the input by the magnetic field of a transformer
- B. A crystal oscillator in which variable frequency is obtained by placing the crystal in a strong magnetic field
- C. A UHF or microwave oscillator consisting of a diode vacuum tube with a specially shaped anode, surrounded by an external magnet
- D. A reference standard oscillator in which the oscillations are synchronized by magnetic coupling to a rubidium gas tube

E7H07

**C. A UHF or microwave oscillator consisting of a diode vacuum tube with a specially shaped anode, surrounded by an external magnet**

ARRL Extra Manual: Page 6-20

Ham Academy Lesson: 4B

Extra Class Questions valid thru 06-30-2016  
Emergency Amateur Radio Club - [www.earchi.org/education](http://www.earchi.org/education)

E7H08

**What is a Gunn diode oscillator?**

- A. An oscillator based on the negative resistance properties of properly-doped semiconductors
- B. An oscillator based on the argon gas diode
- C. A highly stable reference oscillator based on the tee-notch principle
- D. A highly stable reference oscillator based on the hot-carrier effect

E7H08

**A. An oscillator based on the negative resistance properties of properly-doped semiconductors**

ARRL Extra Manual: Page 6-20

Ham Academy Lesson: 4B

Extra Class Questions valid thru 06-30-2016  
Emergency Amateur Radio Club - [www.earchi.org/education](http://www.earchi.org/education)

E8A14

**Which of these methods is commonly used to convert analog signals to digital signals?**

- A. Sequential sampling
- B. Harmonic regeneration
- C. Level shifting
- D. Phase reversal

E8A14

**A. Sequential sampling**

ARRL Extra Manual: Page 6-21

Ham Academy Lesson: 4B

Extra Class Questions valid thru 06-30-2016  
Emergency Amateur Radio Club - [www.earchi.org/education](http://www.earchi.org/education)

E7E08

**What are the principal frequencies that appear at the output of a mixer circuit?**

- A. Two and four times the original frequency
- B. The sum, difference and square root of the input frequencies
- C. The two input frequencies along with their sum and difference frequencies
- D. 1.414 and 0.707 times the input frequency

E7E08

**C. The two input frequencies along with their sum and difference frequencies**

ARRL Extra Manual: Page 6-25

Ham Academy Lesson: 4B

Extra Class Questions valid thru 06-30-2016  
Emergency Amateur Radio Club - [www.earchi.org/education](http://www.earchi.org/education)

E7E09

**What occurs when an excessive amount of signal energy reaches a mixer circuit?**

- A. Spurious mixer products are generated
- B. Mixer blanking occurs
- C. Automatic limiting occurs
- D. A beat frequency is generated

E7E09

**A. Spurious mixer products are generated**

ARRL Extra Manual: Page 6-25

Ham Academy Lesson: 4B

Extra Class Questions valid thru 06-30-2016  
Emergency Amateur Radio Club - [www.earchi.org/education](http://www.earchi.org/education)

E7E07

**What is meant by the term baseband in radio communications?**

- A. The lowest frequency band that the transmitter or receiver covers
- B. The frequency components present in the modulating signal
- C. The unmodulated bandwidth of the transmitted signal
- D. The basic oscillator frequency in an FM transmitter that is multiplied to increase the deviation and carrier frequency

E7E07

**B. The frequency components present in the modulating signal**

ARRL Extra Manual: Page 6-27

Ham Academy Lesson: 4B

Extra Class Questions valid thru 06-30-2016  
Emergency Amateur Radio Club - [www.earchi.org/education](http://www.earchi.org/education)

E7E04

**What is one way a single-sideband phone signal can be generated?**

- A. By using a balanced modulator followed by a filter
- B. By using a reactance modulator followed by a mixer
- C. By using a loop modulator followed by a mixer
- D. By driving a product detector with a DSB signal

E7E04

**A. By using a balanced modulator followed by a filter**

ARRL Extra Manual: Page 6-28

Ham Academy Lesson: 4B

Extra Class Questions valid thru 06-30-2016  
Emergency Amateur Radio Club - [www.earchi.org/education](http://www.earchi.org/education)



E7C09

**What type of digital signal processing filter might be used to generate an SSB signal?**

- A. An adaptive filter
- B. A notch filter
- C. A Hilbert-transform filter
- D. An elliptical filter

E7C09

**C. A Hilbert-transform filter**

ARRL Extra Manual: Page 6-29

Ham Academy Lesson: 4C

Extra Class Questions valid thru 06-30-2016  
Emergency Amateur Radio Club - [www.earchi.org/education](http://www.earchi.org/education)

E7E13

**Which of the following describes a common means of generating an SSB signal when using digital signal processing?**

- A. Mixing products are converted to voltages and subtracted by adder circuits
- B. A frequency synthesizer removes the unwanted sidebands
- C. Emulation of quartz crystal filter characteristics
- D. The quadrature method

E7E13

**D. The quadrature method**

ARRL Extra Manual: Page 6-29

Ham Academy Lesson: 4C

Extra Class Questions valid thru 06-30-2016  
Emergency Amateur Radio Club - [www.earchi.org/education](http://www.earchi.org/education)

E7E01

**Which of the following can be used to generate FM phone emissions?**

- A. A balanced modulator on the audio amplifier
- B. A reactance modulator on the oscillator
- C. A reactance modulator on the final amplifier
- D. A balanced modulator on the oscillator

E7E01

**B. A reactance modulator on the oscillator**

ARRL Extra Manual: Page 6-30

Ham Academy Lesson: 4C

Extra Class Questions valid thru 06-30-2016  
Emergency Amateur Radio Club - [www.earchi.org/education](http://www.earchi.org/education)

E7E02

**What is the function of a reactance modulator?**

- A. To produce PM signals by using an electrically variable resistance
- B. To produce AM signals by using an electrically variable inductance or capacitance
- C. To produce AM signals by using an electrically variable resistance
- D. To produce PM signals by using an electrically variable inductance or capacitance

E7E02

**D. To produce PM signals by using an electrically variable inductance or capacitance**

ARRL Extra Manual: Page 6-30

Ham Academy Lesson: 4C

Extra Class Questions valid thru 06-30-2016  
Emergency Amateur Radio Club - [www.earchi.org/education](http://www.earchi.org/education)

E7E03

**How does an analog phase modulator function?**

- A. By varying the tuning of a microphone preamplifier to produce PM signals
- B. By varying the tuning of an amplifier tank circuit to produce AM signals
- C. By varying the tuning of an amplifier tank circuit to produce PM signals
- D. By varying the tuning of a microphone preamplifier to produce AM signals

E7E03

**C. By varying the tuning of an amplifier tank circuit to produce PM signals**

ARRL Extra Manual: Page 6-30

Ham Academy Lesson: 4C

Extra Class Questions valid thru 06-30-2016  
Emergency Amateur Radio Club - [www.earchi.org/education](http://www.earchi.org/education)

E7E05

**What circuit is added to an FM transmitter to boost the higher audio frequencies?**

- A. A de-emphasis network
- B. A heterodyne suppressor
- C. An audio prescaler
- D. A pre-emphasis network

E7E05

**D. A pre-emphasis network**

ARRL Extra Manual: Page 6-31

Ham Academy Lesson: 4C

Extra Class Questions valid thru 06-30-2016  
Emergency Amateur Radio Club - [www.earchi.org/education](http://www.earchi.org/education)

E7E06

**Why is de-emphasis commonly used in FM communications receivers?**

- A. For compatibility with transmitters using phase modulation
- B. To reduce impulse noise reception
- C. For higher efficiency
- D. To remove third-order distortion products

E7E06

**A. For compatibility with transmitters using phase modulation**

ARRL Extra Manual: Page 6-31

Ham Academy Lesson: 4C

Extra Class Questions valid thru 06-30-2016  
Emergency Amateur Radio Club - [www.earchi.org/education](http://www.earchi.org/education)

E7E10

**How does a diode detector function?**

- A. By rectification and filtering of RF signals
- B. By breakdown of the Zener voltage
- C. By mixing signals with noise in the transition region of the diode
- D. By sensing the change of reactance in the diode with respect to frequency

E7E10

**A. By rectification and filtering of RF signals**

ARRL Extra Manual: Page 6-31

Ham Academy Lesson: 4C

Extra Class Questions valid thru 06-30-2016  
Emergency Amateur Radio Club - [www.earchi.org/education](http://www.earchi.org/education)

E7E11

**Which of the following types of detector is well suited for demodulating SSB signals?**

- A. Discriminator
- B. Phase detector
- C. Product detector
- D. Phase comparator

E7E11

**C. Product detector**

ARRL Extra Manual: Page 6-32

Ham Academy Lesson: 4C

Extra Class Questions valid thru 06-30-2016  
Emergency Amateur Radio Club - [www.earchi.org/education](http://www.earchi.org/education)

E7E14

**What is meant by direct conversion when referring to a software defined receiver?**

- A. Software is converted from source code to object code during operation of the receiver
- B. Incoming RF is converted to the IF frequency by rectification to generate the control voltage for a voltage controlled oscillator
- C. Incoming RF is mixed to "baseband" for analog-to-digital conversion and subsequent processing
- D. Software is generated in machine language, avoiding the need for compilers

E7E14

**C. Incoming RF is mixed to "baseband" for analog-to-digital conversion and subsequent processing**

ARRL Extra Manual: Page 6-32

Ham Academy Lesson: 4C

Extra Class Questions valid thru 06-30-2016  
Emergency Amateur Radio Club - [www.earchi.org/education](http://www.earchi.org/education)

E7E12

**What is a frequency discriminator stage in a FM receiver?**

- A. An FM generator circuit
- B. A circuit for filtering two closely adjacent signals
- C. An automatic band-switching circuit
- D. A circuit for detecting FM signals

E7E12

**D. A circuit for detecting FM signals**

ARRL Extra Manual: Page 6-33

Ham Academy Lesson: 4C

Extra Class Questions valid thru 06-30-2016  
Emergency Amateur Radio Club - [www.earchi.org/education](http://www.earchi.org/education)

E7H13

**What is the capture range of a phase-locked loop circuit?**

- A. The frequency range over which the circuit can lock
- B. The voltage range over which the circuit can lock
- C. The input impedance range over which the circuit can lock
- D. The range of time it takes the circuit to lock

E7H13

**A. The frequency range over which the circuit can lock**

ARRL Extra Manual: Page 6-34

Ham Academy Lesson: 4C

Extra Class Questions valid thru 06-30-2016  
Emergency Amateur Radio Club - [www.earchi.org/education](http://www.earchi.org/education)

E7H14

**What is a phase-locked loop circuit?**

- A. An electronic servo loop consisting of a ratio detector, reactance modulator, and voltage-controlled oscillator
- B. An electronic circuit also known as a monostable multivibrator
- C. An electronic servo loop consisting of a phase detector, a low-pass filter, a voltage-controlled oscillator, and a stable reference oscillator
- D. An electronic circuit consisting of a precision push-pull amplifier with a differential input

E7H14

**C. An electronic servo loop consisting of a phase detector, a low-pass filter, a voltage-controlled oscillator, and a stable reference oscillator**

ARRL Extra Manual: Page 6-34

Ham Academy Lesson: 4C

Extra Class Questions valid thru 06-30-2016

Emergency Amateur Radio Club - [www.earchi.org/education](http://www.earchi.org/education)

E7H17

**Why is a phase-locked loop often used as part of a variable frequency synthesizer for receivers and transmitters?**

- A. It generates FM sidebands
- B. It eliminates the need for a voltage controlled oscillator
- C. It makes it possible for a VFO to have the same degree of frequency stability as a crystal oscillator
- D. It can be used to generate or demodulate SSB signals by quadrature phase synchronization

E7H17

**C. It makes it possible for a VFO to have the same degree of frequency stability as a crystal oscillator**

ARRL Extra Manual: Page 6-34

Ham Academy Lesson: 4C

Extra Class Questions valid thru 06-30-2016

Emergency Amateur Radio Club - [www.earchi.org/education](http://www.earchi.org/education)

E7H09

**What type of frequency synthesizer circuit uses a phase accumulator, lookup table, digital to analog converter and a low-pass anti-alias filter?**

- A. A direct digital synthesizer
- B. A hybrid synthesizer
- C. A phase locked loop synthesizer
- D. A diode-switching matrix synthesizer

E7H09

**A. A direct digital synthesizer**

ARRL Extra Manual: Page 6-35

Ham Academy Lesson: 4C

Extra Class Questions valid thru 06-30-2016

Emergency Amateur Radio Club - [www.earchi.org/education](http://www.earchi.org/education)

E7H10

**What information is contained in the lookup table of a direct digital frequency synthesizer?**

- A. The phase relationship between a reference oscillator and the output waveform
- B. The amplitude values that represent a sine-wave output
- C. The phase relationship between a voltage-controlled oscillator and the output waveform
- D. The synthesizer frequency limits and frequency values stored in the radio memories

E7H10

**B. The amplitude values that represent a sine-wave output**

ARRL Extra Manual: Page 6-35

Ham Academy Lesson: 4C

Extra Class Questions valid thru 06-30-2016

Emergency Amateur Radio Club - [www.earchi.org/education](http://www.earchi.org/education)

E7H12

**Which of the following is a principal component of a direct digital synthesizer (DDS)?**

- A. Phase splitter
- B. Hex inverter
- C. Chroma demodulator
- D. Phase accumulator

E7H12

**D. Phase accumulator**

ARRL Extra Manual: Page 6-35

Ham Academy Lesson: 4C

Extra Class Questions valid thru 06-30-2016  
Emergency Amateur Radio Club - [www.earchi.org/education](http://www.earchi.org/education)

E7H15

**Which of these functions can be performed by a phase-locked loop?**

- A. Wide-band AF and RF power amplification
- B. Comparison of two digital input signals, digital pulse counter
- C. Photovoltaic conversion, optical coupling
- D. Frequency synthesis, FM demodulation

E7H15

**D. Frequency synthesis, FM demodulation**

ARRL Extra Manual: Page 6-35

Ham Academy Lesson: 4C

Extra Class Questions valid thru 06-30-2016  
Emergency Amateur Radio Club - [www.earchi.org/education](http://www.earchi.org/education)

E7H16

**Why is the short-term stability of the reference oscillator important in the design of a phase locked loop (PLL) frequency synthesizer?**

- A. Any amplitude variations in the reference oscillator signal will prevent the loop from locking to the desired signal
- B. Any phase variations in the reference oscillator signal will produce phase noise in the synthesizer output
- C. Any phase variations in the reference oscillator signal will produce harmonic distortion in the modulating signal
- D. Any amplitude variations in the reference oscillator signal will prevent the loop from changing frequency

E7H16

**B. Any phase variations in the reference oscillator signal will produce phase noise in the synthesizer output**

ARRL Extra Manual: Page 6-35

Ham Academy Lesson: 4C

Extra Class Questions valid thru 06-30-2016  
Emergency Amateur Radio Club - [www.earchi.org/education](http://www.earchi.org/education)

E7H18

**What are the major spectral impurity components of phase-locked loop synthesizers?**

- A. Phase noise
- B. Digital conversion noise
- C. Spurious signals at discrete frequencies
- D. Nyquist limit noise

E7H18

**A. Phase noise**

ARRL Extra Manual: Page 6-35

Ham Academy Lesson: 4C

Extra Class Questions valid thru 06-30-2016  
Emergency Amateur Radio Club - [www.earchi.org/education](http://www.earchi.org/education)

E7C10

**Which of the following filters would be the best choice for use in a 2 meter repeater duplexer?**

- A. A crystal filter
- B. A cavity filter
- C. A DSP filter
- D. An L-C filter

E7C10

**B. A cavity filter**

ARRL Extra Manual: Page 6-36

Ham Academy Lesson: 4C

Extra Class Questions valid thru 06-30-2016

Emergency Amateur Radio Club - [www.earchi.org/education](http://www.earchi.org/education)

E7H11

**What are the major spectral impurity components of direct digital synthesizers?**

- A. Broadband noise
- B. Digital conversion noise
- C. Spurious signals at discrete frequencies
- D. Nyquist limit noise

E7H11

**C. Spurious signals at discrete frequencies**

ARRL Extra Manual: Page 6-36

Ham Academy Lesson: 4C

Extra Class Questions valid thru 06-30-2016

Emergency Amateur Radio Club - [www.earchi.org/education](http://www.earchi.org/education)

E7C05

**Which filter type is described as having ripple in the passband and a sharp cutoff?**

- A. A Butterworth filter
- B. An active LC filter
- C. A passive op-amp filter
- D. A Chebyshev filter

E7C05

**D. A Chebyshev filter**

ARRL Extra Manual: Page 6-38

Ham Academy Lesson: 4C

Extra Class Questions valid thru 06-30-2016

Emergency Amateur Radio Club - [www.earchi.org/education](http://www.earchi.org/education)

E7C06

**What are the distinguishing features of an elliptical filter?**

- A. Gradual passband rolloff with minimal stop band ripple
- B. Extremely flat response over its pass band with gradually rounded stop band corners
- C. Extremely sharp cutoff with one or more notches in the stop band
- D. Gradual passband rolloff with extreme stop band ripple

E7C06

**C. Extremely sharp cutoff with one or more notches in the stop band**

ARRL Extra Manual: Page 6-38

Ham Academy Lesson: 4C

Extra Class Questions valid thru 06-30-2016

Emergency Amateur Radio Club - [www.earchi.org/education](http://www.earchi.org/education)

E7C07

**What kind of filter would you use to attenuate an interfering carrier signal while receiving an SSB transmission?**

- A. A band-pass filter
- B. A notch filter
- C. A Pi-network filter
- D. An all-pass filter

E7C07

**B. A notch filter**

ARRL Extra Manual: Page 6-38

Ham Academy Lesson: 4C

Extra Class Questions valid thru 06-30-2016  
Emergency Amateur Radio Club - [www.earchi.org/education](http://www.earchi.org/education)

E7C14

**Which of these modes is most affected by non-linear phase response in a receiver IF filter?**

- A. Meteor Scatter
- B. Single-Sideband voice
- C. Digital
- D. Video

E7C14

**C. Digital**

ARRL Extra Manual: Page 6-38

Ham Academy Lesson: 4C

Extra Class Questions valid thru 06-30-2016  
Emergency Amateur Radio Club - [www.earchi.org/education](http://www.earchi.org/education)

E7G02

**What is the effect of ringing in a filter?**

- A. An echo caused by a long time delay
- B. A reduction in high frequency response
- C. Partial cancellation of the signal over a range of frequencies
- D. Undesired oscillations added to the desired signal

E7G02

**D. Undesired oscillations added to the desired signal**

ARRL Extra Manual: Page 6-38

Ham Academy Lesson: 4C

Extra Class Questions valid thru 06-30-2016  
Emergency Amateur Radio Club - [www.earchi.org/education](http://www.earchi.org/education)

E6E01

**What is a crystal lattice filter?**

- A. A power supply filter made with interlaced quartz crystals
- B. An audio filter made with four quartz crystals that resonate at 1-kHz intervals
- C. A filter with wide bandwidth and shallow skirts made using quartz crystals
- D. A filter with narrow bandwidth and steep skirts made using quartz crystals

E6E01

**D. A filter with narrow bandwidth and steep skirts made using quartz crystals**

ARRL Extra Manual: Page 6-39

Ham Academy Lesson: 4C

Extra Class Questions valid thru 06-30-2016  
Emergency Amateur Radio Club - [www.earchi.org/education](http://www.earchi.org/education)

E6E02

**Which of the following factors has the greatest effect in helping determine the bandwidth and response shape of a crystal ladder filter?**

- A. The relative frequencies of the individual crystals
- B. The DC voltage applied to the quartz crystal
- C. The gain of the RF stage preceding the filter
- D. The amplitude of the signals passing through the filter

E6E02

**A. The relative frequencies of the individual crystals**

ARRL Extra Manual: Page 6-39

Ham Academy Lesson: 4C

Extra Class Questions valid thru 06-30-2016  
Emergency Amateur Radio Club - [www.earchi.org/education](http://www.earchi.org/education)

E6E12

**What is a "Jones filter" as used as part of a HF receiver IF stage?**

- A. An automatic notch filter
- B. A variable bandwidth crystal lattice filter
- C. A special filter that emphasizes image responses
- D. A filter that removes impulse noise

E6E12

**B. A variable bandwidth crystal lattice filter**

ARRL Extra Manual: Page 6-39

Ham Academy Lesson: 4C

Extra Class Questions valid thru 06-30-2016  
Emergency Amateur Radio Club - [www.earchi.org/education](http://www.earchi.org/education)

E7G01

**What primarily determines the gain and frequency characteristics of an op-amp RC active filter?**

- A. The values of capacitors and resistors built into the op-amp
- B. The values of capacitors and resistors external to the op-amp
- C. The input voltage and frequency of the op-amp's DC power supply
- D. The output voltage and smoothness of the op-amp's DC power supply

E7G01

**B. The values of capacitors and resistors external to the op-amp**

ARRL Extra Manual: Page 6-39

Ham Academy Lesson: 4C

Extra Class Questions valid thru 06-30-2016  
Emergency Amateur Radio Club - [www.earchi.org/education](http://www.earchi.org/education)

E7G03

**Which of the following is an advantage of using an op-amp instead of LC elements in an audio filter?**

- A. Op-amps are more rugged
- B. Op-amps are fixed at one frequency
- C. Op-amps are available in more varieties than are LC elements
- D. Op-amps exhibit gain rather than insertion loss

E7G03

**D. Op-amps exhibit gain rather than insertion loss**

ARRL Extra Manual: Page 6-39

Ham Academy Lesson: 4C

Extra Class Questions valid thru 06-30-2016  
Emergency Amateur Radio Club - [www.earchi.org/education](http://www.earchi.org/education)



E7G04

**Which of the following is a type of capacitor best suited for use in high-stability op-amp RC active filter circuits?**

- A. Electrolytic
- B. Disc ceramic
- C. Polystyrene
- D. Paper

E7G04

**C. Polystyrene**

ARRL Extra Manual: Page 6-40

Ham Academy Lesson: 4D

Extra Class Questions valid thru 06-30-2016  
Emergency Amateur Radio Club - [www.earchi.org/education](http://www.earchi.org/education)

E7G05

**How can unwanted ringing and audio instability be prevented in a multi-section op-amp RC audio filter circuit?**

- A. Restrict both gain and Q
- B. Restrict gain, but increase Q
- C. Restrict Q, but increase gain
- D. Increase both gain and Q

E7G05

**A. Restrict both gain and Q**

ARRL Extra Manual: Page 6-40

Ham Academy Lesson: 4D

Extra Class Questions valid thru 06-30-2016  
Emergency Amateur Radio Club - [www.earchi.org/education](http://www.earchi.org/education)

E7G06

**Which of the following is the most appropriate use of an op-amp active filter?**

- A. As a high-pass filter used to block RFI at the input to receivers
- B. As a low-pass filter used between a transmitter and a transmission line
- C. For smoothing power-supply output
- D. As an audio filter in a receiver

E7G06

**D. As an audio filter in a receiver**

ARRL Extra Manual: Page 6-40

Ham Academy Lesson: 4D

Extra Class Questions valid thru 06-30-2016  
Emergency Amateur Radio Club - [www.earchi.org/education](http://www.earchi.org/education)

E7C08

**What kind of digital signal processing audio filter might be used to remove unwanted noise from a received SSB signal?**

- A. An adaptive filter
- B. A crystal-lattice filter
- C. A Hilbert-transform filter
- D. A phase-inverting filter

E7C08

**A. An adaptive filter**

ARRL Extra Manual: Page 6-41

Ham Academy Lesson: 4D

Extra Class Questions valid thru 06-30-2016  
Emergency Amateur Radio Club - [www.earchi.org/education](http://www.earchi.org/education)

E7C04

**How does an impedance-matching circuit transform a complex impedance to a resistive impedance?**

- A. It introduces negative resistance to cancel the resistive part of impedance
- B. It introduces transconductance to cancel the reactive part of impedance
- C. It cancels the reactive part of the impedance and changes the resistive part to a desired value
- D. Network resistances are substituted for load resistances and reactances are matched to the resistances

E7C04

**C. It cancels the reactive part of the impedance and changes the resistive part to a desired value**

ARRL Extra Manual: Page 6-42

Ham Academy Lesson: 4D

Extra Class Questions valid thru 06-30-2016  
Emergency Amateur Radio Club - [www.earchi.org/education](http://www.earchi.org/education)

E7B09

**Which of the following describes how the loading and tuning capacitors are to be adjusted when tuning a vacuum tube RF power amplifier that employs a pi-network output circuit?**

- A. The loading capacitor is set to maximum capacitance and the tuning capacitor is adjusted for minimum allowable plate current
- B. The tuning capacitor is set to maximum capacitance and the loading capacitor is adjusted for minimum plate permissible current
- C. The loading capacitor is adjusted to minimum plate current while alternately adjusting the tuning capacitor for maximum allowable plate current
- D. The tuning capacitor is adjusted for minimum plate current, while the loading capacitor is adjusted for maximum permissible plate current

E7B09

**D. The tuning capacitor is adjusted for minimum plate current, while the loading capacitor is adjusted for maximum permissible plate current**

ARRL Extra Manual: Page 6-43

Ham Academy Lesson: 4D

Extra Class Questions valid thru 06-30-2016  
Emergency Amateur Radio Club - [www.earchi.org/education](http://www.earchi.org/education)

E7C01

**How are the capacitors and inductors of a low-pass filter Pi-network arranged between the network's input and output?**

- A. Two inductors are in series between the input and output, and a capacitor is connected between the two inductors and ground
- B. Two capacitors are in series between the input and output and an inductor is connected between the two capacitors and ground
- C. An inductor is connected between the input and ground, another inductor is connected between the output and ground, and a capacitor is connected between the input and output
- D. A capacitor is connected between the input and ground, another capacitor is connected between the output and ground, and an inductor is connected between input and output

E7C01

**D. A capacitor is connected between the input and ground, another capacitor is connected between the output and ground, and an inductor is connected between input and output**

ARRL Extra Manual: Page 6-43

Ham Academy Lesson: 4D

Extra Class Questions valid thru 06-30-2016  
Emergency Amateur Radio Club - [www.earchi.org/education](http://www.earchi.org/education)

E7C03

**What advantage does a Pi-L-network have over a Pi-network for impedance matching between the final amplifier of a vacuum-tube transmitter and an antenna?**

- A. Greater harmonic suppression
- B. Higher efficiency
- C. Lower losses
- D. Greater transformation range

E7C03

**A. Greater harmonic suppression**

ARRL Extra Manual: Page 6-43

Ham Academy Lesson: 4D

Extra Class Questions valid thru 06-30-2016  
Emergency Amateur Radio Club - [www.earchi.org/education](http://www.earchi.org/education)

E7C11

**Which of the following is the common name for a filter network which is equivalent to two L networks connected back-to-back with the inductors in series and the capacitors in shunt at the input and output?**

- A. Pi-L
- B. Cascode
- C. Omega
- D. Pi

E7C11

**D. Pi**

ARRL Extra Manual: Page 6-43

Ham Academy Lesson: 4D

Extra Class Questions valid thru 06-30-2016  
Emergency Amateur Radio Club - [www.earchi.org/education](http://www.earchi.org/education)

E7C12

**Which of the following describes a Pi-L network used for matching a vacuum-tube final amplifier to a 50-ohm unbalanced output?**

- A. A Phase Inverter Load network
- B. A Pi network with an additional series inductor on the output
- C. A network with only three discrete parts
- D. A matching network in which all components are isolated from ground

E7C12

**B. A Pi network with an additional series inductor on the output**

ARRL Extra Manual: Page 6-43

Ham Academy Lesson: 4D

Extra Class Questions valid thru 06-30-2016  
Emergency Amateur Radio Club - [www.earchi.org/education](http://www.earchi.org/education)

E7C13

**What is one advantage of a Pi matching network over an L matching network consisting of a single inductor and a single capacitor?**

- A. The Q of Pi networks can be varied depending on the component values chosen
- B. L networks cannot perform impedance transformation
- C. Pi networks have fewer components
- D. Pi networks are designed for balanced input and output

E7C13

**A. The Q of Pi networks can be varied depending on the component values chosen**

ARRL Extra Manual: Page 6-43

Ham Academy Lesson: 4D

Extra Class Questions valid thru 06-30-2016  
Emergency Amateur Radio Club - [www.earchi.org/education](http://www.earchi.org/education)

E7C02

**A T-network with series capacitors and a parallel shunt inductor has which of the following properties?**

- A. It is a low-pass filter
- B. It is a band-pass filter
- C. It is a high-pass filter
- D. It is a notch filter

E7C02

**C. It is a high-pass filter**

ARRL Extra Manual: Page 6-44

Ham Academy Lesson: 4D

Extra Class Questions valid thru 06-30-2016  
Emergency Amateur Radio Club - [www.earchi.org/education](http://www.earchi.org/education)

E7D01

**What is one characteristic of a linear electronic voltage regulator?**

- A. It has a ramp voltage as its output
- B. It eliminates the need for a pass transistor
- C. The control element duty cycle is proportional to the line or load conditions
- D. The conduction of a control element is varied to maintain a constant output voltage

E7D01

**D. The conduction of a control element is varied to maintain a constant output voltage**

ARRL Extra Manual: Page 6-44

Ham Academy Lesson: 4D

Extra Class Questions valid thru 06-30-2016  
Emergency Amateur Radio Club - [www.earchi.org/education](http://www.earchi.org/education)

E7D05

**Which of the following types of linear voltage regulator places a constant load on the unregulated voltage source?**

- A. A constant current source
- B. A series regulator
- C. A shunt current source
- D. A shunt regulator

E7D05

**D. A shunt regulator**

ARRL Extra Manual: Page 6-44

Ham Academy Lesson: 4D

Extra Class Questions valid thru 06-30-2016  
Emergency Amateur Radio Club - [www.earchi.org/education](http://www.earchi.org/education)

E7D08

**What type of circuit is shown in Figure E7-3?**

- A. Switching voltage regulator
- B. Grounded emitter amplifier
- C. Linear voltage regulator
- D. Emitter follower

E7D08

**C. Linear voltage regulator**

ARRL Extra Manual: Page 6-44

Ham Academy Lesson: 4D

Extra Class Questions valid thru 06-30-2016  
Emergency Amateur Radio Club - [www.earchi.org/education](http://www.earchi.org/education)

E7D12

**What is the purpose of R2 in the circuit shown in Figure E7-3?**

- A. It provides fixed bias for Q1
- B. It provides fixed bias for D1
- C. It decouples hum from D1
- D. It provides a constant minimum load for Q1

E7D12

**D. It provides a constant minimum load for Q1**

ARRL Extra Manual: Page 6-44

Ham Academy Lesson: 4D

Extra Class Questions valid thru 06-30-2016  
Emergency Amateur Radio Club - [www.earchi.org/education](http://www.earchi.org/education)

E7D03

**What device is typically used as a stable reference voltage in a linear voltage regulator?**

- A. A Zener diode
- B. A tunnel diode
- C. An SCR
- D. A varactor diode

E7D03

**A. A Zener diode**

ARRL Extra Manual: Page 6-45

Ham Academy Lesson: 4D

Extra Class Questions valid thru 06-30-2016  
Emergency Amateur Radio Club - [www.earchi.org/education](http://www.earchi.org/education)

E7D04

**Which of the following types of linear voltage regulator usually make the most efficient use of the primary power source?**

- A. A series current source
- B. A series regulator
- C. A shunt regulator
- D. A shunt current source

E7D04

**B. A series regulator**

ARRL Extra Manual: Page 6-45

Ham Academy Lesson: 4D

Extra Class Questions valid thru 06-30-2016  
Emergency Amateur Radio Club - [www.earchi.org/education](http://www.earchi.org/education)

E7D06

**What is the purpose of Q1 in the circuit shown in Figure E7-3?**

- A. It provides negative feedback to improve regulation
- B. It provides a constant load for the voltage source
- C. It increases the current-handling capability of the regulator
- D. It provides D1 with current

E7D06

**C. It increases the current-handling capability of the regulator**

ARRL Extra Manual: Page 6-45

Ham Academy Lesson: 4D

Extra Class Questions valid thru 06-30-2016  
Emergency Amateur Radio Club - [www.earchi.org/education](http://www.earchi.org/education)

E7D07

**What is the purpose of C2 in the circuit shown in Figure E7-3?**

- A. It bypasses hum around D1
- B. It is a brute force filter for the output
- C. To self-resonate at the hum frequency
- D. To provide fixed DC bias for Q1

E7D07

**A. It bypasses hum around D1**

ARRL Extra Manual: Page 6-45

Ham Academy Lesson: 4D

Extra Class Questions valid thru 06-30-2016  
Emergency Amateur Radio Club - [www.earchi.org/education](http://www.earchi.org/education)

E7D09

**What is the purpose of C1 in the circuit shown in Figure E7-3?**

- A. It resonates at the ripple frequency
- B. It provides fixed bias for Q1
- C. It decouples the output
- D. It filters the supply voltage

E7D09

**D. It filters the supply voltage**

ARRL Extra Manual: Page 6-45

Ham Academy Lesson: 4D

Extra Class Questions valid thru 06-30-2016  
Emergency Amateur Radio Club - [www.earchi.org/education](http://www.earchi.org/education)

E7D10

**What is the purpose of C3 in the circuit shown in Figure E7-3?**

- A. It prevents self-oscillation
- B. It provides brute force filtering of the output
- C. It provides fixed bias for Q1
- D. It clips the peaks of the ripple

E7D10

**A. It prevents self-oscillation**

ARRL Extra Manual: Page 6-45

Ham Academy Lesson: 4D

Extra Class Questions valid thru 06-30-2016  
Emergency Amateur Radio Club - [www.earchi.org/education](http://www.earchi.org/education)

E7D11

**What is the purpose of R1 in the circuit shown in Figure E7-3?**

- A. It provides a constant load to the voltage source
- B. It couples hum to D1
- C. It supplies current to D1
- D. It bypasses hum around D1

E7D11

**C. It supplies current to D1**

ARRL Extra Manual: Page 6-45

Ham Academy Lesson: 4D

Extra Class Questions valid thru 06-30-2016  
Emergency Amateur Radio Club - [www.earchi.org/education](http://www.earchi.org/education)

E7D13

**What is the purpose of D1 in the circuit shown in Figure E7-3?**

- A. To provide line voltage stabilization
- B. To provide a voltage reference
- C. Peak clipping
- D. Hum filtering

E7D13

**B. To provide a voltage reference**

ARRL Extra Manual: Page 6-45

Ham Academy Lesson: 4D

Extra Class Questions valid thru 06-30-2016  
Emergency Amateur Radio Club - [www.earchi.org/education](http://www.earchi.org/education)

E7D02

**What is one characteristic of a switching electronic voltage regulator?**

- A. The resistance of a control element is varied in direct proportion to the line voltage or load current
- B. It is generally less efficient than a linear regulator
- C. The control device's duty cycle is controlled to produce a constant average output voltage
- D. It gives a ramp voltage at its output

E7D02

**C. The control device's duty cycle is controlled to produce a constant average output voltage**

ARRL Extra Manual: Page 6-46

Ham Academy Lesson: 4D

Extra Class Questions valid thru 06-30-2016

Emergency Amateur Radio Club - [www.earchi.org/education](http://www.earchi.org/education)

E7D15

**What is the purpose of a "step-start" circuit in a high-voltage power supply?**

- A. To provide a dual-voltage output for reduced power applications
- B. To compensate for variations of the incoming line voltage
- C. To allow for remote control of the power supply
- D. To allow the filter capacitors to charge gradually

E7D15

**D. To allow the filter capacitors to charge gradually**

ARRL Extra Manual: Page 6-46

Ham Academy Lesson: 4D

Extra Class Questions valid thru 06-30-2016

Emergency Amateur Radio Club - [www.earchi.org/education](http://www.earchi.org/education)

E7D16

**When several electrolytic filter capacitors are connected in series to increase the operating voltage of a power supply filter circuit, why should resistors be connected across each capacitor?**

- A. To equalize, as much as possible, the voltage drop across each capacitor
- B. To provide a safety bleeder to discharge the capacitors when the supply is off
- C. To provide a minimum load current to reduce voltage excursions at light loads
- D. All of these choices are correct

E7D16

**D. All of these choices are correct**

ARRL Extra Manual: Page 6-46

Ham Academy Lesson: 4D

Extra Class Questions valid thru 06-30-2016

Emergency Amateur Radio Club - [www.earchi.org/education](http://www.earchi.org/education)

E7D17

**What is the primary reason that a high-frequency inverter type high-voltage power supply can be both less expensive and lighter in weight than a conventional power supply?**

- A. The inverter design does not require any output filtering
- B. It uses a diode bridge rectifier for increased output
- C. The high frequency inverter design uses much smaller transformers and filter components for an equivalent power output
- D. It uses a large power-factor compensation capacitor to create "free power" from the unused portion of the AC cycle

E7D17

**C. The high frequency inverter design uses much smaller transformers and filter components for an equivalent power output**

ARRL Extra Manual: Page 6-46

Ham Academy Lesson: 4D

Extra Class Questions valid thru 06-30-2016

Emergency Amateur Radio Club - [www.earchi.org/education](http://www.earchi.org/education)

E7D14

**What is one purpose of a "bleeder" resistor in a conventional (unregulated) power supply?**

- A. To cut down on waste heat generated by the power supply
- B. To balance the low-voltage filament windings
- C. To improve output voltage regulation
- D. To boost the amount of output current

E7D14

**C. To improve output voltage regulation**

ARRL Extra Manual: Page 6-47

Ham Academy Lesson: 4D

Extra Class Questions valid thru 06-30-2016

Emergency Amateur Radio Club - [www.earchi.org/education](http://www.earchi.org/education)

E8A08

**What is the period of a wave?**

- A. The time required to complete one cycle
- B. The number of degrees in one cycle
- C. The number of zero crossings in one cycle
- D. The amplitude of the wave

E8A08

**A. The time required to complete one cycle**

ARRL Extra Manual: Page 7-2

Ham Academy Lesson: 5A

Extra Class Questions valid thru 06-30-2016

Emergency Amateur Radio Club - [www.earchi.org/education](http://www.earchi.org/education)

E8A09

**What type of waveform is produced by human speech?**

- A. Sinusoidal
- B. Logarithmic
- C. Irregular
- D. Trapezoidal

E8A09

**C. Irregular**

ARRL Extra Manual: Page 7-3

Ham Academy Lesson: 5A

Extra Class Questions valid thru 06-30-2016

Emergency Amateur Radio Club - [www.earchi.org/education](http://www.earchi.org/education)

E8A01

**What type of wave is made up of a sine wave plus all of its odd harmonics?**

- A. A square wave
- B. A sine wave
- C. A cosine wave
- D. A tangent wave

E8A01

**A. A square wave**

ARRL Extra Manual: Page 7-4

Ham Academy Lesson: 5A

Extra Class Questions valid thru 06-30-2016

Emergency Amateur Radio Club - [www.earchi.org/education](http://www.earchi.org/education)



E8A02

**What type of wave has a rise time significantly faster than its fall time (or vice versa)?**

- A. A cosine wave
- B. A square wave
- C. A sawtooth wave
- D. A sine wave

E8A02

**C. A sawtooth wave**

ARRL Extra Manual: Page 7-4

Ham Academy Lesson: 5A

Extra Class Questions valid thru 06-30-2016  
Emergency Amateur Radio Club - [www.earchi.org/education](http://www.earchi.org/education)

E8A03

**What type of wave is made up of sine waves of a given fundamental frequency plus all its harmonics?**

- A. A sawtooth wave
- B. A square wave
- C. A sine wave
- D. A cosine wave

E8A03

**A. A sawtooth wave**

ARRL Extra Manual: Page 7-4

Ham Academy Lesson: 5A

Extra Class Questions valid thru 06-30-2016  
Emergency Amateur Radio Club - [www.earchi.org/education](http://www.earchi.org/education)

E8A10

**Which of the following is a distinguishing characteristic of a pulse waveform?**

- A. Regular sinusoidal oscillations
- B. Narrow bursts of energy separated by periods of no signal
- C. A series of tones that vary between two frequencies
- D. A signal that contains three or more discrete tones

E8A10

**B. Narrow bursts of energy separated by periods of no signal**

ARRL Extra Manual: Page 7-4

Ham Academy Lesson: 5A

Extra Class Questions valid thru 06-30-2016  
Emergency Amateur Radio Club - [www.earchi.org/education](http://www.earchi.org/education)

E8A04

**What is equivalent to the root-mean-square value of an AC voltage?**

- A. The AC voltage found by taking the square of the average value of the peak AC voltage
- B. The DC voltage causing the same amount of heating in a given resistor as the corresponding peak AC voltage
- C. The DC voltage causing the same amount of heating in a resistor as the corresponding RMS AC voltage
- D. The AC voltage found by taking the square root of the average AC value

E8A04

**C. The DC voltage causing the same amount of heating in a resistor as the corresponding RMS AC voltage**

ARRL Extra Manual: Page 7-5

Ham Academy Lesson: 5A

Extra Class Questions valid thru 06-30-2016  
Emergency Amateur Radio Club - [www.earchi.org/education](http://www.earchi.org/education)

E8A05

**What would be the most accurate way of measuring the RMS voltage of a complex waveform?**

- A. By using a grid dip meter
- B. By measuring the voltage with a D'Arsonval meter
- C. By using an absorption wavemeter
- D. By measuring the heating effect in a known resistor

E8A05

**D. By measuring the heating effect in a known resistor**

ARRL Extra Manual: Page 7-5

Ham Academy Lesson: 5A

Extra Class Questions valid thru 06-30-2016  
Emergency Amateur Radio Club - [www.earchi.org/education](http://www.earchi.org/education)

E8D02

**What is the relationship between the peak-to-peak voltage and the peak voltage amplitude of a symmetrical waveform?**

- A. 0.707:1
- B. 2:1
- C. 1.414:1
- D. 4:1

E8D02

**B. 2:1**

ARRL Extra Manual: Page 7-5

Ham Academy Lesson: 5A

Extra Class Questions valid thru 06-30-2016  
Emergency Amateur Radio Club - [www.earchi.org/education](http://www.earchi.org/education)

E8D03

**What input-amplitude parameter is valuable in evaluating the signal-handling capability of a Class A amplifier?**

- A. Peak voltage
- B. RMS voltage
- C. Average power
- D. Resting voltage

E8D03

**A. Peak voltage**

ARRL Extra Manual: Page 7-5

Ham Academy Lesson: 5A

Extra Class Questions valid thru 06-30-2016  
Emergency Amateur Radio Club - [www.earchi.org/education](http://www.earchi.org/education)

E8D05

**If an RMS-reading AC voltmeter reads 65 volts on a sinusoidal waveform, what is the peak-to-peak voltage?**

- A. 46 volts
- B. 92 volts
- C. 130 volts
- D. 184 volts

E8D05

**D. 184 volts**

ARRL Extra Manual: Page 7-6

Ham Academy Lesson: 5A

Extra Class Questions valid thru 06-30-2016  
Emergency Amateur Radio Club - [www.earchi.org/education](http://www.earchi.org/education)

E8D12

**What is the peak voltage of a sinusoidal waveform if an RMS-reading voltmeter reads 34 volts?**

- A. 123 volts
- B. 96 volts
- C. 55 volts
- D. 48 volts

E8D12

**D. 48 volts**

ARRL Extra Manual: Page 7-6

Ham Academy Lesson: 5A

Extra Class Questions valid thru 06-30-2016  
Emergency Amateur Radio Club - [www.earchi.org/education](http://www.earchi.org/education)

E8D13

**Which of the following is a typical value for the peak voltage at a standard U.S. household electrical outlet?**

- A. 240 volts
- B. 170 volts
- C. 120 volts
- D. 340 volts

E8D13

**B. 170 volts**

ARRL Extra Manual: Page 7-6

Ham Academy Lesson: 5A

Extra Class Questions valid thru 06-30-2016  
Emergency Amateur Radio Club - [www.earchi.org/education](http://www.earchi.org/education)

E8D14

**Which of the following is a typical value for the peak-to-peak voltage at a standard U.S. household electrical outlet?**

- A. 240 volts
- B. 120 volts
- C. 340 volts
- D. 170 volts

E8D14

**C. 340 volts**

ARRL Extra Manual: Page 7-6

Ham Academy Lesson: 5A

Extra Class Questions valid thru 06-30-2016  
Emergency Amateur Radio Club - [www.earchi.org/education](http://www.earchi.org/education)

E8D15

**Which of the following is a typical value for the RMS voltage at a standard U.S. household electrical power outlet?**

- A. 120V AC
- B. 340V AC
- C. 85V AC
- D. 170V AC

E8D15

**A. 120V AC**

ARRL Extra Manual: Page 7-6

Ham Academy Lesson: 5A

Extra Class Questions valid thru 06-30-2016  
Emergency Amateur Radio Club - [www.earchi.org/education](http://www.earchi.org/education)

E8D16

**What is the RMS value of a 340-volt peak-to-peak pure sine wave?**

- A. 120V AC
- B. 170V AC
- C. 240V AC
- D. 300V AC

E8D16

**A. 120V AC**

ARRL Extra Manual: Page 7-6

Ham Academy Lesson: 5A

Extra Class Questions valid thru 06-30-2016  
Emergency Amateur Radio Club - [www.earchi.org/education](http://www.earchi.org/education)

E8D11

**What is the average power dissipated by a 50-ohm resistive load during one complete RF cycle having a peak voltage of 35 volts?**

- A. 12.2 watts
- B. 9.9 watts
- C. 24.5 watts
- D. 16 watts

E8D11

**A. 12.2 watts**

ARRL Extra Manual: Page 7-6\*

Ham Academy Lesson: 5A

Extra Class Questions valid thru 06-30-2016  
Emergency Amateur Radio Club - [www.earchi.org/education](http://www.earchi.org/education)

E8A07

**What determines the PEP-to-average power ratio of a single-sideband phone signal?**

- A. The frequency of the modulating signal
- B. The characteristics of the modulating signal
- C. The degree of carrier suppression
- D. The amplifier gain

E8A07

**B. The characteristics of the modulating signal**

ARRL Extra Manual: Page 7-8

Ham Academy Lesson: 5A

Extra Class Questions valid thru 06-30-2016  
Emergency Amateur Radio Club - [www.earchi.org/education](http://www.earchi.org/education)

E8D04

**What is the PEP output of a transmitter that develops a peak voltage of 30 volts into a 50-ohm load?**

- A. 4.5 watts
- B. 9 watts
- C. 16 watts
- D. 18 watts

E8D04

**B. 9 watts**

ARRL Extra Manual: Page 7-8

Ham Academy Lesson: 5A

Extra Class Questions valid thru 06-30-2016  
Emergency Amateur Radio Club - [www.earchi.org/education](http://www.earchi.org/education)

E8D06

**What is the advantage of using a peak-reading wattmeter to monitor the output of a SSB phone transmitter?**

- A. It is easier to determine the correct tuning of the output circuit
- B. It gives a more accurate display of the PEP output when modulation is present
- C. It makes it easier to detect high SWR on the feed line
- D. It can determine if any flat-topping is present during modulation peaks

E8D06

**B. It gives a more accurate display of the PEP output when modulation is present**

ARRL Extra Manual: Page 7-8

Ham Academy Lesson: 5A

Extra Class Questions valid thru 06-30-2016  
Emergency Amateur Radio Club - [www.earchi.org/education](http://www.earchi.org/education)

E8D10

**What type of meter should be used to monitor the output signal of a voice-modulated single-sideband transmitter to ensure you do not exceed the maximum allowable power?**

- A. An SWR meter reading in the forward direction
- B. A modulation meter
- C. An average reading wattmeter
- D. A peak-reading wattmeter

E8D10

**D. A peak-reading wattmeter**

ARRL Extra Manual: Page 7-8

Ham Academy Lesson: 5A

Extra Class Questions valid thru 06-30-2016  
Emergency Amateur Radio Club - [www.earchi.org/education](http://www.earchi.org/education)

E8A06

**What is the approximate ratio of PEP-to-average power in a typical single-sideband phone signal?**

- A. 2.5 to 1
- B. 25 to 1
- C. 1 to 1
- D. 100 to 1

E8A06

**A. 2.5 to 1**

ARRL Extra Manual: Page 7-9

Ham Academy Lesson: 5A

Extra Class Questions valid thru 06-30-2016  
Emergency Amateur Radio Club - [www.earchi.org/education](http://www.earchi.org/education)

E8D07

**What is an electromagnetic wave?**

- A. Alternating currents in the core of an electromagnet
- B. A wave consisting of two electric fields at right angles to each other
- C. A wave consisting of an electric field and a magnetic field oscillating at right angles to each other
- D. A wave consisting of two magnetic fields at right angles to each other

E8D07

**C. A wave consisting of an electric field and a magnetic field oscillating at right angles to each other**

ARRL Extra Manual: Page 7-9

Ham Academy Lesson: 5A

Extra Class Questions valid thru 06-30-2016  
Emergency Amateur Radio Club - [www.earchi.org/education](http://www.earchi.org/education)

E8D08

**Which of the following best describes electromagnetic waves traveling in free space?**

- A. Electric and magnetic fields become aligned as they travel
- B. The energy propagates through a medium with a high refractive index
- C. The waves are reflected by the ionosphere and return to their source
- D. Changing electric and magnetic fields propagate the energy

E8D08

**D. Changing electric and magnetic fields propagate the energy**

ARRL Extra Manual: Page 7-9

Ham Academy Lesson: 5A

Extra Class Questions valid thru 06-30-2016  
Emergency Amateur Radio Club - [www.earchi.org/education](http://www.earchi.org/education)

E8D09

**What is meant by circularly polarized electromagnetic waves?**

- A. Waves with an electric field bent into a circular shape
- B. Waves with a rotating electric field
- C. Waves that circle the Earth
- D. Waves produced by a loop antenna

E8D09

**B. Waves with a rotating electric field**

ARRL Extra Manual: Page 7-11

Ham Academy Lesson: 5A

Extra Class Questions valid thru 06-30-2016  
Emergency Amateur Radio Club - [www.earchi.org/education](http://www.earchi.org/education)

E4B08

**Which of the following is a characteristic of a good DC voltmeter?**

- A. High reluctance input
- B. Low reluctance input
- C. High impedance input
- D. Low impedance input

E4B08

**C. High impedance input**

ARRL Extra Manual: Page 7-12

Ham Academy Lesson: 5B

Extra Class Questions valid thru 06-30-2016  
Emergency Amateur Radio Club - [www.earchi.org/education](http://www.earchi.org/education)

E4B12

**What is the significance of voltmeter sensitivity expressed in ohms per volt?**

- A. The full scale reading of the voltmeter multiplied by its ohms per volt rating will provide the input impedance of the voltmeter
- B. When used as a galvanometer, the reading in volts multiplied by the ohms/volt will determine the power drawn by the device under test
- C. When used as an ohmmeter, the reading in ohms divided by the ohms/volt will determine the voltage applied to the circuit
- D. When used as an ammeter, the full scale reading in amps divided by ohms/volt will determine the size of shunt needed

E4B12

**A. The full scale reading of the voltmeter multiplied by its ohms per volt rating will provide the input impedance of the voltmeter**

ARRL Extra Manual: Page 7-12

Ham Academy Lesson: 5B

Extra Class Questions valid thru 06-30-2016  
Emergency Amateur Radio Club - [www.earchi.org/education](http://www.earchi.org/education)

E4B02

**What is an advantage of using a bridge circuit to measure impedance?**

- A. It provides an excellent match under all conditions
- B. It is relatively immune to drift in the signal generator source
- C. The measurement is based on obtaining a signal null, which can be done very precisely
- D. It can display results directly in Smith chart format

E4B02

**C. The measurement is based on obtaining a signal null, which can be done very precisely**

ARRL Extra Manual: Page 7-13

Ham Academy Lesson: 5B

Extra Class Questions valid thru 06-30-2016  
Emergency Amateur Radio Club - [www.earchi.org/education](http://www.earchi.org/education)

E4B14

**What happens if a dip meter is too tightly coupled to a tuned circuit being checked?**

- A. Harmonics are generated
- B. A less accurate reading results
- C. Cross modulation occurs
- D. Intermodulation distortion occurs

E4B14

**B. A less accurate reading results**

ARRL Extra Manual: Page 7-13

Ham Academy Lesson: 5B

Extra Class Questions valid thru 06-30-2016  
Emergency Amateur Radio Club - [www.earchi.org/education](http://www.earchi.org/education)

E4B01

**Which of the following factors most affects the accuracy of a frequency counter?**

- A. Input attenuator accuracy
- B. Time base accuracy
- C. Decade divider accuracy
- D. Temperature coefficient of the logic

E4B01

**B. Time base accuracy**

ARRL Extra Manual: Page 7-14

Ham Academy Lesson: 5B

Extra Class Questions valid thru 06-30-2016  
Emergency Amateur Radio Club - [www.earchi.org/education](http://www.earchi.org/education)

E4B03

**If a frequency counter with a specified accuracy of +/- 1.0 ppm reads 146,520,000 Hz, what is the most the actual frequency being measured could differ from the reading?**

- A. 165.2 Hz
- B. 14.652 kHz
- C. 146.52 Hz
- D. 1.4652 MHz

E4B03

**C. 146.52 Hz**

ARRL Extra Manual: Page 7-15

Ham Academy Lesson: 5B

Extra Class Questions valid thru 06-30-2016  
Emergency Amateur Radio Club - [www.earchi.org/education](http://www.earchi.org/education)

E4B04

**If a frequency counter with a specified accuracy of +/- 0.1 ppm reads 146,520,000 Hz, what is the most the actual frequency being measured could differ from the reading?**

- A. 14.652 Hz
- B. 0.1 MHz
- C. 1.4652 Hz
- D. 1.4652 kHz

E4B04

**A. 14.652 Hz**

ARRL Extra Manual: Page 7-15

Ham Academy Lesson: 5B

Extra Class Questions valid thru 06-30-2016  
Emergency Amateur Radio Club - [www.earchi.org/education](http://www.earchi.org/education)

E4B05

**If a frequency counter with a specified accuracy of +/- 10 ppm reads 146,520,000 Hz, what is the most the actual frequency being measured could differ from the reading?**

- A. 146.52 Hz
- B. 10 Hz
- C. 146.52 kHz
- D. 1465.20 Hz

E4B05

**D. 1465.20 Hz**

ARRL Extra Manual: Page 7-15

Ham Academy Lesson: 5B

Extra Class Questions valid thru 06-30-2016  
Emergency Amateur Radio Club - [www.earchi.org/education](http://www.earchi.org/education)

E4A11

**Which of these instruments could be used for detailed analysis of digital signals?**

- A. Dip meter
- B. Oscilloscope
- C. Ohmmeter
- D. Q meter

E4A11

**B. Oscilloscope**

ARRL Extra Manual: Page 7-16

Ham Academy Lesson: 5B

Extra Class Questions valid thru 06-30-2016  
Emergency Amateur Radio Club - [www.earchi.org/education](http://www.earchi.org/education)

E8D01

**Which of the following is the easiest voltage amplitude parameter to measure when viewing a pure sine wave signal on an analog oscilloscope?**

- A. Peak-to-peak voltage
- B. RMS voltage
- C. Average voltage
- D. DC voltage

E8D01

**A. Peak-to-peak voltage**

ARRL Extra Manual: Page 7-16

Ham Academy Lesson: 5B

Extra Class Questions valid thru 06-30-2016  
Emergency Amateur Radio Club - [www.earchi.org/education](http://www.earchi.org/education)



E4A01

**How does a spectrum analyzer differ from an oscilloscope?**

- A. A spectrum analyzer measures ionospheric reflection; an oscilloscope displays electrical signals
- B. A spectrum analyzer displays the peak amplitude of signals; an oscilloscope displays the average amplitude of signals
- C. A spectrum analyzer displays signals in the frequency domain; an oscilloscope displays signals in the time domain
- D. A spectrum analyzer displays radio frequencies; an oscilloscope displays audio frequencies

E4A01

**C. A spectrum analyzer displays signals in the frequency domain; an oscilloscope displays signals in the time domain**

ARRL Extra Manual: Page 7-17

Ham Academy Lesson: 5B

Extra Class Questions valid thru 06-30-2016  
Emergency Amateur Radio Club - [www.earchi.org/education](http://www.earchi.org/education)

E4B07

**Which of the following is good practice when using an oscilloscope probe?**

- A. Keep the signal ground connection of the probe as short as possible
- B. Never use a high impedance probe to measure a low impedance circuit
- C. Never use a DC-coupled probe to measure an AC circuit
- D. All of these choices are correct

E4B07

**A. Keep the signal ground connection of the probe as short as possible**

ARRL Extra Manual: Page 7-17

Ham Academy Lesson: 5B

Extra Class Questions valid thru 06-30-2016  
Emergency Amateur Radio Club - [www.earchi.org/education](http://www.earchi.org/education)

E4B13

**How is the compensation of an oscilloscope probe typically adjusted?**

- A. A square wave is displayed and the probe is adjusted until the horizontal portions of the displayed wave are as nearly flat as possible
- B. A high frequency sine wave is displayed and the probe is adjusted for maximum amplitude
- C. A frequency standard is displayed and the probe is adjusted until the deflection time is accurate
- D. A DC voltage standard is displayed and the probe is adjusted until the displayed voltage is accurate

E4B13

**A. A square wave is displayed and the probe is adjusted until the horizontal portions of the displayed wave are as nearly flat as possible**

ARRL Extra Manual: Page 7-17

Ham Academy Lesson: 5B

Extra Class Questions valid thru 06-30-2016  
Emergency Amateur Radio Club - [www.earchi.org/education](http://www.earchi.org/education)

E4A02

**Which of the following parameters would a spectrum analyzer display on the horizontal axis?**

- A. SWR
- B. Q
- C. Time
- D. Frequency

E4A02

**D. Frequency**

ARRL Extra Manual: Page 7-18

Ham Academy Lesson: 5B

Extra Class Questions valid thru 06-30-2016  
Emergency Amateur Radio Club - [www.earchi.org/education](http://www.earchi.org/education)

E4A03

**Which of the following parameters would a spectrum analyzer display on the vertical axis?**

- A. Amplitude
- B. Duration
- C. SWR
- D. Q

E4A03

**A. Amplitude**

ARRL Extra Manual: Page 7-18

Ham Academy Lesson: 5B

Extra Class Questions valid thru 06-30-2016  
Emergency Amateur Radio Club - [www.earchi.org/education](http://www.earchi.org/education)

E4A04

**Which of the following test instruments is used to display spurious signals from a radio transmitter?**

- A. A spectrum analyzer
- B. A wattmeter
- C. A logic analyzer
- D. A time-domain reflectometer

E4A04

**A. A spectrum analyzer**

ARRL Extra Manual: Page 7-18

Ham Academy Lesson: 5B

Extra Class Questions valid thru 06-30-2016  
Emergency Amateur Radio Club - [www.earchi.org/education](http://www.earchi.org/education)

E4A05

**Which of the following test instruments is used to display intermodulation distortion products in an SSB transmission?**

- A. A wattmeter
- B. A spectrum analyzer
- C. A logic analyzer
- D. A time-domain reflectometer

E4A05

**B. A spectrum analyzer**

ARRL Extra Manual: Page 7-19

Ham Academy Lesson: 5B

Extra Class Questions valid thru 06-30-2016  
Emergency Amateur Radio Club - [www.earchi.org/education](http://www.earchi.org/education)

E4A06

**Which of the following could be determined with a spectrum analyzer?**

- A. The degree of isolation between the input and output ports of a 2 meter duplexer
- B. Whether a crystal is operating on its fundamental or overtone frequency
- C. The spectral output of a transmitter
- D. All of these choices are correct

E4A06

**D. All of these choices are correct**

ARRL Extra Manual: Page 7-19

Ham Academy Lesson: 5B

Extra Class Questions valid thru 06-30-2016  
Emergency Amateur Radio Club - [www.earchi.org/education](http://www.earchi.org/education)

E4A12

**Which of the following procedures is an important precaution to follow when connecting a spectrum analyzer to a transmitter output?**

- A. Use high quality double shielded coaxial cables to reduce signal losses
- B. Attenuate the transmitter output going to the spectrum analyzer
- C. Match the antenna to the load
- D. All of these choices are correct

E4A12

**B. Attenuate the transmitter output going to the spectrum analyzer**

ARRL Extra Manual: Page 7-19

Ham Academy Lesson: 5B

Extra Class Questions valid thru 06-30-2016  
Emergency Amateur Radio Club - [www.earchi.org/education](http://www.earchi.org/education)

E4B10

**Which of the following describes a method to measure intermodulation distortion in an SSB transmitter?**

- A. Modulate the transmitter with two non-harmonically related radio frequencies and observe the RF output with a spectrum analyzer
- B. Modulate the transmitter with two non-harmonically related audio frequencies and observe the RF output with a spectrum analyzer
- C. Modulate the transmitter with two harmonically related audio frequencies and observe the RF output with a peak reading wattmeter
- D. Modulate the transmitter with two harmonically related audio frequencies and observe the RF output with a logic analyzer

E4B10

**B. Modulate the transmitter with two non-harmonically related audio frequencies and observe the RF output with a spectrum analyzer**

ARRL Extra Manual: Page 7-19

Ham Academy Lesson: 5B

Extra Class Questions valid thru 06-30-2016  
Emergency Amateur Radio Club - [www.earchi.org/education](http://www.earchi.org/education)

E4A10

**Which of the following tests establishes that a silicon NPN junction transistor is biased on?**

- A. Measure base-to-emitter resistance with an ohmmeter; it should be approximately 6 to 7 ohms
- B. Measure base-to-emitter resistance with an ohmmeter; it should be approximately 0.6 to 0.7 ohms
- C. Measure base-to-emitter voltage with a voltmeter; it should be approximately 6 to 7 volts
- D. Measure base-to-emitter voltage with a voltmeter; it should be approximately 0.6 to 0.7 volts

E4A10

**D. Measure base-to-emitter voltage with a voltmeter; it should be approximately 0.6 to 0.7 volts**

ARRL Extra Manual: Page 7-20

Ham Academy Lesson: 5B

Extra Class Questions valid thru 06-30-2016  
Emergency Amateur Radio Club - [www.earchi.org/education](http://www.earchi.org/education)

E8B05

**What is the deviation ratio of an FM-phone signal having a maximum frequency swing of plus-or-minus 5 kHz when the maximum modulation frequency is 3 kHz?**

- A. 60
- B. 0.167
- C. 0.6
- D. 1.67

E8B05

**D. 1.67**

ARRL Extra Manual: Page 7-23

Ham Academy Lesson: 5B

Extra Class Questions valid thru 06-30-2016  
Emergency Amateur Radio Club - [www.earchi.org/education](http://www.earchi.org/education)

E8B06

**What is the deviation ratio of an FM-phone signal having a maximum frequency swing of plus or minus 7.5 kHz when the maximum modulation frequency is 3.5 kHz?**

- A. 2.14
- B. 0.214
- C. 0.47
- D. 47

E8B06

**A. 2.14**

ARRL Extra Manual: Page 7-23

Ham Academy Lesson: 5B

Extra Class Questions valid thru 06-30-2016  
Emergency Amateur Radio Club - [www.earchi.org/education](http://www.earchi.org/education)

E8B09

**What is meant by deviation ratio?**

- A. The ratio of the audio modulating frequency to the center carrier frequency
- B. The ratio of the maximum carrier frequency deviation to the highest audio modulating frequency
- C. The ratio of the carrier center frequency to the audio modulating frequency
- D. The ratio of the highest audio modulating frequency to the average audio modulating frequency

E8B09

**B. The ratio of the maximum carrier frequency deviation to the highest audio modulating frequency**

ARRL Extra Manual: Page 7-23

Ham Academy Lesson: 5B

Extra Class Questions valid thru 06-30-2016  
Emergency Amateur Radio Club - [www.earchi.org/education](http://www.earchi.org/education)

E8B01

**What is the term for the ratio between the frequency deviation of an RF carrier wave, and the modulating frequency of its corresponding FM-phone signal?**

- A. FM compressibility
- B. Quieting index
- C. Percentage of modulation
- D. Modulation index

E8B01

**D. Modulation index**

ARRL Extra Manual: Page 7-24

Ham Academy Lesson: 5B

Extra Class Questions valid thru 06-30-2016  
Emergency Amateur Radio Club - [www.earchi.org/education](http://www.earchi.org/education)

E8B02

**How does the modulation index of a phase-modulated emission vary with RF carrier frequency (the modulated frequency)?**

- A. It increases as the RF carrier frequency increases
- B. It decreases as the RF carrier frequency increases
- C. It varies with the square root of the RF carrier frequency
- D. It does not depend on the RF carrier frequency

E8B02

**D. It does not depend on the RF carrier frequency**

ARRL Extra Manual: Page 7-24

Ham Academy Lesson: 5B

Extra Class Questions valid thru 06-30-2016  
Emergency Amateur Radio Club - [www.earchi.org/education](http://www.earchi.org/education)

E8B03

**What is the modulation index of an FM-phone signal having a maximum frequency deviation of 3000 Hz either side of the carrier frequency, when the modulating frequency is 1000 Hz?**

- A. 3
- B. 0.3
- C. 3000
- D. 1000

E8B03

**A. 3**

ARRL Extra Manual: Page 7-24

Ham Academy Lesson: 5B

Extra Class Questions valid thru 06-30-2016  
Emergency Amateur Radio Club - [www.earchi.org/education](http://www.earchi.org/education)

E8B04

**What is the modulation index of an FM-phone signal having a maximum carrier deviation of plus or minus 6 kHz when modulated with a 2-kHz modulating frequency?**

- A. 6000
- B. 3
- C. 2000
- D. 1/3

E8B04

**B. 3**

ARRL Extra Manual: Page 7-24

Ham Academy Lesson: 5B

Extra Class Questions valid thru 06-30-2016  
Emergency Amateur Radio Club - [www.earchi.org/education](http://www.earchi.org/education)

E1B12 [97.307]

**What is the highest modulation index permitted at the highest modulation frequency for angle modulation?**

- A. .5
- B. 1.0
- C. 2.0
- D. 3.0

E1B12

**B. 1.0**

ARRL Extra Manual: Page 7-25

Ham Academy Lesson: 5C

Extra Class Questions valid thru 06-30-2016  
Emergency Amateur Radio Club - [www.earchi.org/education](http://www.earchi.org/education)

E8A11

**What is one use for a pulse modulated signal?**

- A. Linear amplification
- B. PSK31 data transmission
- C. Multiphase power transmission
- D. Digital data transmission

E8A11

**D. Digital data transmission**

ARRL Extra Manual: Page 7-25

Ham Academy Lesson: 5C

Extra Class Questions valid thru 06-30-2016  
Emergency Amateur Radio Club - [www.earchi.org/education](http://www.earchi.org/education)

E8B08

**What parameter does the modulating signal vary in a pulse-position modulation system?**

- A. The number of pulses per second
- B. The amplitude of the pulses
- C. The duration of the pulses
- D. The time at which each pulse occurs

E8B08

**D. The time at which each pulse occurs**

ARRL Extra Manual: Page 7-25

Ham Academy Lesson: 5C

Extra Class Questions valid thru 06-30-2016  
Emergency Amateur Radio Club - [www.earchi.org/education](http://www.earchi.org/education)

E8B07

**When using a pulse-width modulation system, why is the transmitter's peak power greater than its average power?**

- A. The signal duty cycle is less than 100%
- B. The signal reaches peak amplitude only when voice modulated
- C. The signal reaches peak amplitude only when voltage spikes are generated within the modulator
- D. The signal reaches peak amplitude only when the pulses are also amplitude modulated

E8B07

**A. The signal duty cycle is less than 100%**

ARRL Extra Manual: Page 7-26

Ham Academy Lesson: 5C

Extra Class Questions valid thru 06-30-2016  
Emergency Amateur Radio Club - [www.earchi.org/education](http://www.earchi.org/education)

E8B10

**Which of these methods can be used to combine several separate analog information streams into a single analog radio frequency signal?**

- A. Frequency shift keying
- B. A diversity combiner
- C. Frequency division multiplexing
- D. Pulse compression

E8B10

**C. Frequency division multiplexing**

ARRL Extra Manual: Page 7-26

Ham Academy Lesson: 5C

Extra Class Questions valid thru 06-30-2016  
Emergency Amateur Radio Club - [www.earchi.org/education](http://www.earchi.org/education)

E8B11

**Which of the following describes frequency division multiplexing?**

- A. The transmitted signal jumps from band to band at a predetermined rate
- B. Two or more information streams are merged into a "baseband", which then modulates the transmitter
- C. The transmitted signal is divided into packets of information
- D. Two or more information streams are merged into a digital combiner, which then pulse position modulates the transmitter

E8B11

**B. Two or more information streams are merged into a "baseband", which then modulates the transmitter**

ARRL Extra Manual: Page 7-26

Ham Academy Lesson: 5C

Extra Class Questions valid thru 06-30-2016  
Emergency Amateur Radio Club - [www.earchi.org/education](http://www.earchi.org/education)

E8B12

**What is digital time division multiplexing?**

- A. Two or more data streams are assigned to discrete sub-carriers on an FM transmitter
- B. Two or more signals are arranged to share discrete time slots of a data transmission
- C. Two or more data streams share the same channel by transmitting time of transmission as the sub-carrier
- D. Two or more signals are quadrature modulated to increase bandwidth efficiency

E8B12

**B. Two or more signals are arranged to share discrete time slots of a data transmission**

ARRL Extra Manual: Page 7-26

Ham Academy Lesson: 5C

Extra Class Questions valid thru 06-30-2016  
Emergency Amateur Radio Club - [www.earchi.org/education](http://www.earchi.org/education)

E4D06

**What is the term for unwanted signals generated by the mixing of two or more signals?**

- A. Amplifier desensitization
- B. Neutralization
- C. Adjacent channel interference
- D. Intermodulation interference

E4D06

**D. Intermodulation interference**

ARRL Extra Manual: Page 7-27

Ham Academy Lesson: 5C

Extra Class Questions valid thru 06-30-2016  
Emergency Amateur Radio Club - [www.earchi.org/education](http://www.earchi.org/education)

E4D07

**Which of the following describes the most significant effect of an off-frequency signal when it is causing cross-modulation interference to a desired signal?**

- A. A large increase in background noise
- B. A reduction in apparent signal strength
- C. The desired signal can no longer be heard
- D. The off-frequency unwanted signal is heard in addition to the desired signal

E4D07

**D. The off-frequency unwanted signal is heard in addition to the desired signal**

ARRL Extra Manual: Page 7-27

Ham Academy Lesson: 5C

Extra Class Questions valid thru 06-30-2016  
Emergency Amateur Radio Club - [www.earchi.org/education](http://www.earchi.org/education)

E4D08

**What causes intermodulation in an electronic circuit?**

- A. Too little gain
- B. Lack of neutralization
- C. Nonlinear circuits or devices
- D. Positive feedback

E4D08

**C. Nonlinear circuits or devices**

ARRL Extra Manual: Page 7-27

Ham Academy Lesson: 5C

Extra Class Questions valid thru 06-30-2016  
Emergency Amateur Radio Club - [www.earchi.org/education](http://www.earchi.org/education)

E4D03

**How can intermodulation interference between two repeaters occur?**

- A. When the repeaters are in close proximity and the signals cause feedback in the final amplifier of one or both transmitters
- B. When the repeaters are in close proximity and the signals mix in the final amplifier of one or both transmitters
- C. When the signals from the transmitters are reflected out of phase from airplanes passing overhead
- D. When the signals from the transmitters are reflected in phase from airplanes passing overhead

E4D03

**B. When the repeaters are in close proximity and the signals mix in the final amplifier of one or both transmitters**

ARRL Extra Manual: Page 7-28

Ham Academy Lesson: 5C

Extra Class Questions valid thru 06-30-2016  
Emergency Amateur Radio Club - [www.earchi.org/education](http://www.earchi.org/education)

E4D04

**Which of the following may reduce or eliminate intermodulation interference in a repeater caused by another transmitter operating in close proximity?**

- A. A band-pass filter in the feed line between the transmitter and receiver
- B. A properly terminated circulator at the output of the transmitter
- C. A Class C final amplifier
- D. A Class D final amplifier

E4D04

**B. A properly terminated circulator at the output of the transmitter**

ARRL Extra Manual: Page 7-28

Ham Academy Lesson: 5C

Extra Class Questions valid thru 06-30-2016  
Emergency Amateur Radio Club - [www.earchi.org/education](http://www.earchi.org/education)

E4E11

**Which of the following is the most likely cause if you are hearing combinations of local AM broadcast signals within one or more of the MF or HF ham bands?**

- A. The broadcast station is transmitting an over-modulated signal
- B. Nearby corroded metal joints are mixing and re-radiating the broadcast signals
- C. You are receiving sky wave signals from a distant station
- D. Your station receiver IF amplifier stage is defective

E4E11

**B. Nearby corroded metal joints are mixing and re-radiating the broadcast signals**

ARRL Extra Manual: Page 7-28

Ham Academy Lesson: 5C

Extra Class Questions valid thru 06-30-2016  
Emergency Amateur Radio Club - [www.earchi.org/education](http://www.earchi.org/education)

E4E06

**What is a major cause of atmospheric static?**

- A. Solar radio frequency emissions
- B. Thunderstorms
- C. Geomagnetic storms
- D. Meteor showers

E4E06

**B. Thunderstorms**

ARRL Extra Manual: Page 7-29

Ham Academy Lesson: 5C

Extra Class Questions valid thru 06-30-2016  
Emergency Amateur Radio Club - [www.earchi.org/education](http://www.earchi.org/education)



E4E05

**How can noise from an electric motor be suppressed?**

- A. By installing a high pass filter in series with the motor's power leads
- B. By installing a brute-force AC-line filter in series with the motor leads
- C. By installing a bypass capacitor in series with the motor leads
- D. By using a ground-fault current interrupter in the circuit used to power the motor

E4E05

**B. By installing a brute-force AC-line filter in series with the motor leads**

ARRL Extra Manual: Page 7-30

Ham Academy Lesson: 5C

Extra Class Questions valid thru 06-30-2016  
Emergency Amateur Radio Club - [www.earchi.org/education](http://www.earchi.org/education)

E4E07

**How can you determine if line noise interference is being generated within your home?**

- A. By checking the power line voltage with a time domain reflectometer
- B. By observing the AC power line waveform with an oscilloscope
- C. By turning off the AC power line main circuit breaker and listening on a battery operated radio
- D. By observing the AC power line voltage with a spectrum analyzer

E4E07

**C. By turning off the AC power line main circuit breaker and listening on a battery operated radio**

ARRL Extra Manual: Page 7-30

Ham Academy Lesson: 5C

Extra Class Questions valid thru 06-30-2016  
Emergency Amateur Radio Club - [www.earchi.org/education](http://www.earchi.org/education)

E4E13

**What might be the cause of a loud roaring or buzzing AC line interference that comes and goes at intervals?**

- A. Arcing contacts in a thermostatically controlled device
- B. A defective doorbell or doorbell transformer inside a nearby residence
- C. A malfunctioning illuminated advertising display
- D. All of these choices are correct

E4E13

**D. All of these choices are correct**

ARRL Extra Manual: Page 7-30

Ham Academy Lesson: 5C

Extra Class Questions valid thru 06-30-2016  
Emergency Amateur Radio Club - [www.earchi.org/education](http://www.earchi.org/education)

E4E08

**What type of signal is picked up by electrical wiring near a radio antenna?**

- A. A common-mode signal at the frequency of the radio transmitter
- B. An electrical-sparking signal
- C. A differential-mode signal at the AC power line frequency
- D. Harmonics of the AC power line frequency

E4E08

**A. A common-mode signal at the frequency of the radio transmitter**

ARRL Extra Manual: Page 7-31

Ham Academy Lesson: 5C

Extra Class Questions valid thru 06-30-2016  
Emergency Amateur Radio Club - [www.earchi.org/education](http://www.earchi.org/education)

E4E10

**What is a common characteristic of interference caused by a touch controlled electrical device?**

- A. The interfering signal sounds like AC hum on an AM receiver or a carrier modulated by 60 Hz hum on a SSB or CW receiver
- B. The interfering signal may drift slowly across the HF spectrum
- C. The interfering signal can be several kHz in width and usually repeats at regular intervals across a HF band
- D. All of these choices are correct

E4E10

**D. All of these choices are correct**

ARRL Extra Manual: Page 7-31

Ham Academy Lesson: 5C

Extra Class Questions valid thru 06-30-2016  
Emergency Amateur Radio Club - [www.earchi.org/education](http://www.earchi.org/education)

E4E14

**What is one type of electrical interference that might be caused by the operation of a nearby personal computer?**

- A. A loud AC hum in the audio output of your station receiver
- B. A clicking noise at intervals of a few seconds
- C. The appearance of unstable modulated or unmodulated signals at specific frequencies
- D. A whining type noise that continually pulses off and on

E4E14

**C. The appearance of unstable modulated or unmodulated signals at specific frequencies**

ARRL Extra Manual: Page 7-31

Ham Academy Lesson: 5C

Extra Class Questions valid thru 06-30-2016  
Emergency Amateur Radio Club - [www.earchi.org/education](http://www.earchi.org/education)

E4E01

**Which of the following types of receiver noise can often be reduced by use of a receiver noise blanker?**

- A. Ignition noise
- B. Broadband white noise
- C. Heterodyne interference
- D. All of these choices are correct

E4E01

**A. Ignition noise**

ARRL Extra Manual: Page 7-33

Ham Academy Lesson: 5C

Extra Class Questions valid thru 06-30-2016  
Emergency Amateur Radio Club - [www.earchi.org/education](http://www.earchi.org/education)

E4E03

**Which of the following signals might a receiver noise blanker be able to remove from desired signals?**

- A. Signals which are constant at all IF levels
- B. Signals which appear across a wide bandwidth
- C. Signals which appear at one IF but not another
- D. Signals which have a sharply peaked frequency distribution

E4E03

**B. Signals which appear across a wide bandwidth**

ARRL Extra Manual: Page 7-33

Ham Academy Lesson: 5C

Extra Class Questions valid thru 06-30-2016  
Emergency Amateur Radio Club - [www.earchi.org/education](http://www.earchi.org/education)

E4E04

**How can conducted and radiated noise caused by an automobile alternator be suppressed?**

- A. By installing filter capacitors in series with the DC power lead and by installing a blocking capacitor in the field lead
- B. By installing a noise suppression resistor and a blocking capacitor in both leads
- C. By installing a high-pass filter in series with the radio's power lead and a low-pass filter in parallel with the field lead
- D. By connecting the radio's power leads directly to the battery and by installing coaxial capacitors in line with the alternator leads

E4E04

**D. By connecting the radio's power leads directly to the battery and by installing coaxial capacitors in line with the alternator leads**

ARRL Extra Manual: Page 7-33

Ham Academy Lesson: 5C

Extra Class Questions valid thru 06-30-2016  
Emergency Amateur Radio Club - [www.earchi.org/education](http://www.earchi.org/education)

E4E09

**What undesirable effect can occur when using an IF noise blanker?**

- A. Received audio in the speech range might have an echo effect
- B. The audio frequency bandwidth of the received signal might be compressed
- C. Nearby signals may appear to be excessively wide even if they meet emission standards
- D. FM signals can no longer be demodulated

E4E09

**C. Nearby signals may appear to be excessively wide even if they meet emission standards**

ARRL Extra Manual: Page 7-34

Ham Academy Lesson: 5C

Extra Class Questions valid thru 06-30-2016  
Emergency Amateur Radio Club - [www.earchi.org/education](http://www.earchi.org/education)

E4E12

**What is one disadvantage of using some types of automatic DSP notch-filters when attempting to copy CW signals?**

- A. The DSP filter can remove the desired signal at the same time as it removes interfering signals
- B. Any nearby signal passing through the DSP system will overwhelm the desired signal
- C. Received CW signals will appear to be modulated at the DSP clock frequency
- D. Ringing in the DSP filter will completely remove the spaces between the CW characters

E4E12

**A. The DSP filter can remove the desired signal at the same time as it removes interfering signals**

ARRL Extra Manual: Page 7-34

Ham Academy Lesson: 5C

Extra Class Questions valid thru 06-30-2016  
Emergency Amateur Radio Club - [www.earchi.org/education](http://www.earchi.org/education)

E4E02

**Which of the following types of receiver noise can often be reduced with a DSP noise filter?**

- A. Broadband white noise
- B. Ignition noise
- C. Power line noise
- D. All of these choices are correct

E4E02

**D. All of these choices are correct**

ARRL Extra Manual: Page 7-34

Ham Academy Lesson: 5C

Extra Class Questions valid thru 06-30-2016  
Emergency Amateur Radio Club - [www.earchi.org/education](http://www.earchi.org/education)

E2D02

**What is the definition of baud?**

- A. The number of data symbols transmitted per second
- B. The number of characters transmitted per second
- C. The number of characters transmitted per minute
- D. The number of words transmitted per minute

E2D02

**A. The number of data symbols transmitted per second**

ARRL Extra Manual: Page 8-2

Ham Academy Lesson: 6A

Extra Class Questions valid thru 06-30-2016

Emergency Amateur Radio Club - [www.earchi.org/education](http://www.earchi.org/education)

E8A15

**What would the waveform of a stream of digital data bits look like on a conventional oscilloscope?**

- A. A series of sine waves with evenly spaced gaps
- B. A series of pulses with varying patterns
- C. A running display of alpha-numeric characters
- D. None of the above; this type of signal cannot be seen on a conventional oscilloscope

E8A15

**B. A series of pulses with varying patterns**

ARRL Extra Manual: Page 8-2

Ham Academy Lesson: 6A

Extra Class Questions valid thru 06-30-2016

Emergency Amateur Radio Club - [www.earchi.org/education](http://www.earchi.org/education)

E2E09

**Which of the following HF digital modes uses variable-length coding for bandwidth efficiency?**

- A. RTTY
- B. PACTOR
- C. MT63
- D. PSK31

E2E09

**D. PSK31**

ARRL Extra Manual: Page 8-4

Ham Academy Lesson: 6A

Extra Class Questions valid thru 06-30-2016

Emergency Amateur Radio Club - [www.earchi.org/education](http://www.earchi.org/education)

E8C01

**Which one of the following digital codes consists of elements having unequal length?**

- A. ASCII
- B. AX.25
- C. Baudot
- D. Morse code

E8C01

**D. Morse code**

ARRL Extra Manual: Page 8-4

Ham Academy Lesson: 6A

Extra Class Questions valid thru 06-30-2016

Emergency Amateur Radio Club - [www.earchi.org/education](http://www.earchi.org/education)

E8C02

**What are some of the differences between the Baudot digital code and ASCII?**

- A. Baudot uses four data bits per character, ASCII uses seven or eight; Baudot uses one character as a shift code, ASCII has no shift code
- B. Baudot uses five data bits per character, ASCII uses seven or eight; Baudot uses two characters as shift codes, ASCII has no shift code
- C. Baudot uses six data bits per character, ASCII uses seven or eight; Baudot has no shift code, ASCII uses two characters as shift codes
- D. Baudot uses seven data bits per character, ASCII uses eight; Baudot has no shift code, ASCII uses two characters as shift codes

E8C02

**B. Baudot uses five data bits per character, ASCII uses seven or eight; Baudot uses two characters as shift codes, ASCII has no shift code**

ARRL Extra Manual: Page 8-4

Ham Academy Lesson: 6A

Extra Class Questions valid thru 06-30-2016  
Emergency Amateur Radio Club - [www.earchi.org/education](http://www.earchi.org/education)

E8C03

**What is one advantage of using the ASCII code for data communications?**

- A. It includes built-in error-correction features
- B. It contains fewer information bits per character than any other code
- C. It is possible to transmit both upper and lower case text
- D. It uses one character as a shift code to send numeric and special characters

E8C03

**C. It is possible to transmit both upper and lower case text**

ARRL Extra Manual: Page 8-4

Ham Academy Lesson: 6A

Extra Class Questions valid thru 06-30-2016  
Emergency Amateur Radio Club - [www.earchi.org/education](http://www.earchi.org/education)

E8C12

**What is the advantage of including a parity bit with an ASCII character stream?**

- A. Faster transmission rate
- B. The signal can overpower interfering signals
- C. Foreign language characters can be sent
- D. Some types of errors can be detected

E8C12

**D. Some types of errors can be detected**

ARRL Extra Manual: Page 8-4

Ham Academy Lesson: 6A

Extra Class Questions valid thru 06-30-2016  
Emergency Amateur Radio Club - [www.earchi.org/education](http://www.earchi.org/education)

E8A12

**What type of information can be conveyed using digital waveforms?**

- A. Human speech
- B. Video signals
- C. Data
- D. All of these choices are correct

E8A12

**D. All of these choices are correct**

ARRL Extra Manual: Page 8-5

Ham Academy Lesson: 6A

Extra Class Questions valid thru 06-30-2016  
Emergency Amateur Radio Club - [www.earchi.org/education](http://www.earchi.org/education)

E8A13

**What is an advantage of using digital signals instead of analog signals to convey the same information?**

- A. Less complex circuitry is required for digital signal generation and detection
- B. Digital signals always occupy a narrower bandwidth
- C. Digital signals can be regenerated multiple times without error
- D. All of these choices are correct

E8A13

**C. Digital signals can be regenerated multiple times without error**

ARRL Extra Manual: Page 8-5

Ham Academy Lesson: 6A

Extra Class Questions valid thru 06-30-2016  
Emergency Amateur Radio Club - [www.earchi.org/education](http://www.earchi.org/education)

E2E01

**Which type of modulation is common for data emissions below 30 MHz?**

- A. DTMF tones modulating an FM signal
- B. FSK
- C. Pulse modulation
- D. Spread spectrum

E2E01

**B. FSK**

ARRL Extra Manual: Page 8-6

Ham Academy Lesson: 6A

Extra Class Questions valid thru 06-30-2016  
Emergency Amateur Radio Club - [www.earchi.org/education](http://www.earchi.org/education)

E2E11

**What is the difference between direct FSK and audio FSK?**

- A. Direct FSK applies the data signal to the transmitter VFO
- B. Audio FSK has a superior frequency response
- C. Direct FSK uses a DC-coupled data connection
- D. Audio FSK can be performed anywhere in the transmit chain

E2E11

**A. Direct FSK applies the data signal to the transmitter VFO**

ARRL Extra Manual: Page 8-6

Ham Academy Lesson: 6A

Extra Class Questions valid thru 06-30-2016  
Emergency Amateur Radio Club - [www.earchi.org/education](http://www.earchi.org/education)

E8C05

**What is the necessary bandwidth of a 13-WPM international Morse code transmission?**

- A. Approximately 13 Hz
- B. Approximately 26 Hz
- C. Approximately 52 Hz
- D. Approximately 104 Hz

E8C05

**C. Approximately 52 Hz**

ARRL Extra Manual: Page 8-6

Ham Academy Lesson: 6A

Extra Class Questions valid thru 06-30-2016  
Emergency Amateur Radio Club - [www.earchi.org/education](http://www.earchi.org/education)

E8C06

**What is the necessary bandwidth of a 170-hertz shift, 300-baud ASCII transmission?**

- A. 0.1 Hz
- B. 0.3 kHz
- C. 0.5 kHz
- D. 1.0 kHz

E8C06

**C. 0.5 kHz**

ARRL Extra Manual: Page 8-6

Ham Academy Lesson: 6A

Extra Class Questions valid thru 06-30-2016  
Emergency Amateur Radio Club - [www.earchi.org/education](http://www.earchi.org/education)

E8C07

**What is the necessary bandwidth of a 4800-Hz frequency shift, 9600-baud ASCII FM transmission?**

- A. 15.36 kHz
- B. 9.6 kHz
- C. 4.8 kHz
- D. 5.76 kHz

E8C07

**A. 15.36 kHz**

ARRL Extra Manual: Page 8-6

Ham Academy Lesson: 6A

Extra Class Questions valid thru 06-30-2016  
Emergency Amateur Radio Club - [www.earchi.org/education](http://www.earchi.org/education)

E2D09

**Under clear communications conditions, which of these digital communications modes has the fastest data throughput?**

- A. AMTOR
- B. 170-Hz shift, 45 baud RTTY
- C. PSK31
- D. 300-baud packet

E2D09

**D. 300-baud packet**

ARRL Extra Manual: Page 8-7

Ham Academy Lesson: 6A

Extra Class Questions valid thru 06-30-2016  
Emergency Amateur Radio Club - [www.earchi.org/education](http://www.earchi.org/education)

E2E04

**What is indicated when one of the ellipses in an FSK crossed-ellipse display suddenly disappears?**

- A. Selective fading has occurred
- B. One of the signal filters has saturated
- C. The receiver has drifted 5 kHz from the desired receive frequency
- D. The mark and space signal have been inverted

E2E04

**A. Selective fading has occurred**

ARRL Extra Manual: Page 8-7

Ham Academy Lesson: 6A

Extra Class Questions valid thru 06-30-2016  
Emergency Amateur Radio Club - [www.earchi.org/education](http://www.earchi.org/education)

E2E06

**What is the most common data rate used for HF packet communications?**

- A. 48 baud
- B. 110 baud
- C. 300 baud
- D. 1200 baud

E2E06

**C. 300 baud**

ARRL Extra Manual: Page 8-7

Ham Academy Lesson: 6A

Extra Class Questions valid thru 06-30-2016  
Emergency Amateur Radio Club - [www.earchi.org/education](http://www.earchi.org/education)

E2E08

**Which of the following HF digital modes can be used to transfer binary files?**

- A. Hellschreiber
- B. PACTOR
- C. RTTY
- D. AMTOR

E2E08

**B. PACTOR**

ARRL Extra Manual: Page 8-7

Ham Academy Lesson: 6A

Extra Class Questions valid thru 06-30-2016  
Emergency Amateur Radio Club - [www.earchi.org/education](http://www.earchi.org/education)

E2E10

**Which of these digital communications modes has the narrowest bandwidth?**

- A. MFSK16
- B. 170-Hz shift, 45 baud RTTY
- C. PSK31
- D. 300-baud packet

E2E10

**C. PSK31**

ARRL Extra Manual: Page 8-7

Ham Academy Lesson: 6A

Extra Class Questions valid thru 06-30-2016  
Emergency Amateur Radio Club - [www.earchi.org/education](http://www.earchi.org/education)

E8C04

**What technique is used to minimize the bandwidth requirements of a PSK31 signal?**

- A. Zero-sum character encoding
- B. Reed-Solomon character encoding
- C. Use of sinusoidal data pulses
- D. Use of trapezoidal data pulses

E8C04

**C. Use of sinusoidal data pulses**

ARRL Extra Manual: Page 8-7

Ham Academy Lesson: 6A

Extra Class Questions valid thru 06-30-2016  
Emergency Amateur Radio Club - [www.earchi.org/education](http://www.earchi.org/education)



E2D01

**Which of the following digital modes is especially designed for use for meteor scatter signals?**

- A. WSPR
- B. FSK441
- C. Hellschreiber
- D. APRS

E2D01

**B. FSK441**

ARRL Extra Manual: Page 8-8

Ham Academy Lesson: 6A

Extra Class Questions valid thru 06-30-2016  
Emergency Amateur Radio Club - [www.earchi.org/education](http://www.earchi.org/education)

E2D03

**Which of the following digital modes is especially useful for EME communications?**

- A. FSK441
- B. PACTOR III
- C. Olivia
- D. JT65

E2D03

**D. JT65**

ARRL Extra Manual: Page 8-8

Ham Academy Lesson: 6A

Extra Class Questions valid thru 06-30-2016  
Emergency Amateur Radio Club - [www.earchi.org/education](http://www.earchi.org/education)

E2D12

**How does JT65 improve EME communications?**

- A. It can decode signals many dB below the noise floor using FEC
- B. It controls the receiver to track Doppler shift
- C. It supplies signals to guide the antenna to track the Moon
- D. All of these choices are correct

E2D12

**A. It can decode signals many dB below the noise floor using FEC**

ARRL Extra Manual: Page 8-8

Ham Academy Lesson: 6A

Extra Class Questions valid thru 06-30-2016  
Emergency Amateur Radio Club - [www.earchi.org/education](http://www.earchi.org/education)

E2E07

**What is the typical bandwidth of a properly modulated MFSK16 signal?**

- A. 31 Hz
- B. 316 Hz
- C. 550 Hz
- D. 2.16 kHz

E2E07

**B. 316 Hz**

ARRL Extra Manual: Page 8-8

Ham Academy Lesson: 6A

Extra Class Questions valid thru 06-30-2016  
Emergency Amateur Radio Club - [www.earchi.org/education](http://www.earchi.org/education)

E2E12

**Which type of digital communication does not support keyboard-to-keyboard operation?**

- A. Winlink
- B. RTTY
- C. PSK31
- D. MFSK

E2E12

**A. Winlink**

ARRL Extra Manual: Page 8-8

Ham Academy Lesson: 6B

Extra Class Questions valid thru 06-30-2016  
Emergency Amateur Radio Club - [www.earchi.org/education](http://www.earchi.org/education)

E4A09

**Which of the following describes a good method for measuring the intermodulation distortion of your own PSK signal?**

- A. Transmit into a dummy load, receive the signal on a second receiver, and feed the audio into the sound card of a computer running an appropriate PSK program
- B. Multiply the ALC level on the transmitter during a normal transmission by the average power output
- C. Use an RF voltmeter coupled to the transmitter output using appropriate isolation to prevent damage to the meter
- D. All of these choices are correct

E4A09

**A. Transmit into a dummy load, receive the signal on a second receiver, and feed the audio into the sound card of a computer running an appropriate PSK program**

ARRL Extra Manual: Page 8-8

Ham Academy Lesson: 6B

Extra Class Questions valid thru 06-30-2016  
Emergency Amateur Radio Club - [www.earchi.org/education](http://www.earchi.org/education)

E8C13

**What is one advantage of using JT-65 coding?**

- A. Uses only a 65 Hz bandwidth
- B. The ability to decode signals which have a very low signal to noise ratio
- C. Easily copied by ear if necessary
- D. Permits fast-scan TV transmissions over narrow bandwidth

E8C13

**B. The ability to decode signals which have a very low signal to noise ratio**

ARRL Extra Manual: Page 8-8

Ham Academy Lesson: 6B

Extra Class Questions valid thru 06-30-2016  
Emergency Amateur Radio Club - [www.earchi.org/education](http://www.earchi.org/education)

E2C08

**Why are received spread-spectrum signals resistant to interference?**

- A. Signals not using the spectrum-spreading algorithm are suppressed in the receiver
- B. The high power used by a spread-spectrum transmitter keeps its signal from being easily overpowered
- C. The receiver is always equipped with a digital blanker circuit
- D. If interference is detected by the receiver it will signal the transmitter to change frequencies

E2C08

**A. Signals not using the spectrum-spreading algorithm are suppressed in the receiver**

ARRL Extra Manual: Page 8-9

Ham Academy Lesson: 6B

Extra Class Questions valid thru 06-30-2016  
Emergency Amateur Radio Club - [www.earchi.org/education](http://www.earchi.org/education)

E8C08

**What term describes a wide-bandwidth communications system in which the transmitted carrier frequency varies according to some predetermined sequence?**

- A. Amplitude compandored single sideband
- B. AMTOR
- C. Time-domain frequency modulation
- D. Spread-spectrum communication

E8C08

**D. Spread-spectrum communication**

ARRL Extra Manual: Page 8-9

Ham Academy Lesson: 6B

Extra Class Questions valid thru 06-30-2016  
Emergency Amateur Radio Club - [www.earchi.org/education](http://www.earchi.org/education)

E8C09

**Which of these techniques causes a digital signal to appear as wide-band noise to a conventional receiver?**

- A. Spread-spectrum
- B. Independent sideband
- C. Regenerative detection
- D. Exponential addition

E8C09

**A. Spread-spectrum**

ARRL Extra Manual: Page 8-9

Ham Academy Lesson: 6B

Extra Class Questions valid thru 06-30-2016  
Emergency Amateur Radio Club - [www.earchi.org/education](http://www.earchi.org/education)

E2C09

**How does the spread-spectrum technique of frequency hopping work?**

- A. If interference is detected by the receiver it will signal the transmitter to change frequencies
- B. If interference is detected by the receiver it will signal the transmitter to wait until the frequency is clear
- C. A pseudo-random binary bit stream is used to shift the phase of an RF carrier very rapidly in a particular sequence
- D. The frequency of the transmitted signal is changed very rapidly according to a particular sequence also used by the receiving station

E2C09

**D. The frequency of the transmitted signal is changed very rapidly according to a particular sequence also used by the receiving station**

ARRL Extra Manual: Page 8-10

Ham Academy Lesson: 6B

Extra Class Questions valid thru 06-30-2016  
Emergency Amateur Radio Club - [www.earchi.org/education](http://www.earchi.org/education)

E8C10

**What spread-spectrum communications technique alters the center frequency of a conventional carrier many times per second in accordance with a pseudo-random list of channels?**

- A. Frequency hopping
- B. Direct sequence
- C. Time-domain frequency modulation
- D. Frequency compandored spread-spectrum

E8C10

**A. Frequency hopping**

ARRL Extra Manual: Page 8-10

Ham Academy Lesson: 6B

Extra Class Questions valid thru 06-30-2016  
Emergency Amateur Radio Club - [www.earchi.org/education](http://www.earchi.org/education)

E8C11

**What spread-spectrum communications technique uses a high speed binary bit stream to shift the phase of an RF carrier?**

- A. Frequency hopping
- B. Direct sequence
- C. Binary phase-shift keying
- D. Phase compandored spread-spectrum

E8C11

**B. Direct sequence**

ARRL Extra Manual: Page 8-10

Ham Academy Lesson: 6B

Extra Class Questions valid thru 06-30-2016  
Emergency Amateur Radio Club - [www.earchi.org/education](http://www.earchi.org/education)

E2E02

**What do the letters FEC mean as they relate to digital operation?**

- A. Forward Error Correction
- B. First Error Correction
- C. Fatal Error Correction
- D. Final Error Correction

E2E02

**A. Forward Error Correction**

ARRL Extra Manual: Page 8-11

Ham Academy Lesson: 6B

Extra Class Questions valid thru 06-30-2016  
Emergency Amateur Radio Club - [www.earchi.org/education](http://www.earchi.org/education)

E2E03

**How is Forward Error Correction implemented?**

- A. By the receiving station repeating each block of three data characters
- B. By transmitting a special algorithm to the receiving station along with the data characters
- C. By transmitting extra data that may be used to detect and correct transmission errors
- D. By varying the frequency shift of the transmitted signal according to a predefined algorithm

E2E03

**C. By transmitting extra data that may be used to detect and correct transmission errors**

ARRL Extra Manual: Page 8-11

Ham Academy Lesson: 6B

Extra Class Questions valid thru 06-30-2016  
Emergency Amateur Radio Club - [www.earchi.org/education](http://www.earchi.org/education)

E2E05

**How does ARQ accomplish error correction?**

- A. Special binary codes provide automatic correction
- B. Special polynomial codes provide automatic correction
- C. If errors are detected, redundant data is substituted
- D. If errors are detected, a retransmission is requested

E2E05

**D. If errors are detected, a retransmission is requested**

ARRL Extra Manual: Page 8-11

Ham Academy Lesson: 6B

Extra Class Questions valid thru 06-30-2016  
Emergency Amateur Radio Club - [www.earchi.org/education](http://www.earchi.org/education)

E2B01

**How many times per second is a new frame transmitted in a fast-scan (NTSC) television system?**

- A. 30
- B. 60
- C. 90
- D. 120

E2B01

**A. 30**

ARRL Extra Manual: Page 8-13

Ham Academy Lesson: 6B

Extra Class Questions valid thru 06-30-2016  
Emergency Amateur Radio Club - [www.earchi.org/education](http://www.earchi.org/education)

E2B02

**How many horizontal lines make up a fast-scan (NTSC) television frame?**

- A. 30
- B. 60
- C. 525
- D. 1080

E2B02

**C. 525**

ARRL Extra Manual: Page 8-13

Ham Academy Lesson: 6B

Extra Class Questions valid thru 06-30-2016  
Emergency Amateur Radio Club - [www.earchi.org/education](http://www.earchi.org/education)

E2B03

**How is an interlaced scanning pattern generated in a fast-scan (NTSC) television system?**

- A. By scanning two fields simultaneously
- B. By scanning each field from bottom to top
- C. By scanning lines from left to right in one field and right to left in the next
- D. By scanning odd numbered lines in one field and even numbered ones in the next

E2B03

**D. By scanning odd numbered lines in one field and even numbered ones in the next**

ARRL Extra Manual: Page 8-13

Ham Academy Lesson: 6B

Extra Class Questions valid thru 06-30-2016  
Emergency Amateur Radio Club - [www.earchi.org/education](http://www.earchi.org/education)

E2B04

**What is blanking in a video signal?**

- A. Synchronization of the horizontal and vertical sync pulses
- B. Turning off the scanning beam while it is traveling from right to left or from bottom to top
- C. Turning off the scanning beam at the conclusion of a transmission
- D. Transmitting a black and white test pattern

E2B04

**B. Turning off the scanning beam while it is traveling from right to left or from bottom to top**

ARRL Extra Manual: Page 8-13

Ham Academy Lesson: 6B

Extra Class Questions valid thru 06-30-2016  
Emergency Amateur Radio Club - [www.earchi.org/education](http://www.earchi.org/education)

E2B16

**Which of the following is the video standard used by North American Fast Scan ATV stations?**

- A. PAL
- B. DRM
- C. Scottie
- D. NTSC

E2B16

**D. NTSC**

ARRL Extra Manual: Page 8-13

Ham Academy Lesson: 6B

Extra Class Questions valid thru 06-30-2016  
Emergency Amateur Radio Club - [www.earchi.org/education](http://www.earchi.org/education)

E2B07

**What is the name of the signal component that carries color information in NTSC video?**

- A. Luminance
- B. Chroma
- C. Hue
- D. Spectral Intensity

E2B07

**B. Chroma**

ARRL Extra Manual: Page 8-15

Ham Academy Lesson: 6B

Extra Class Questions valid thru 06-30-2016  
Emergency Amateur Radio Club - [www.earchi.org/education](http://www.earchi.org/education)

E2B05

**Which of the following is an advantage of using vestigial sideband for standard fast- scan TV transmissions?**

- A. The vestigial sideband carries the audio information
- B. The vestigial sideband contains chroma information
- C. Vestigial sideband reduces bandwidth while allowing for simple video detector circuitry
- D. Vestigial sideband provides high frequency emphasis to sharpen the picture

E2B05

**C. Vestigial sideband reduces bandwidth while allowing for simple video detector circuitry**

ARRL Extra Manual: Page 8-16

Ham Academy Lesson: 6B

Extra Class Questions valid thru 06-30-2016  
Emergency Amateur Radio Club - [www.earchi.org/education](http://www.earchi.org/education)

E2B06

**What is vestigial sideband modulation?**

- A. Amplitude modulation in which one complete sideband and a portion of the other are transmitted
- B. A type of modulation in which one sideband is inverted
- C. Narrow-band FM transmission achieved by filtering one sideband from the audio before frequency modulating the carrier
- D. Spread spectrum modulation achieved by applying FM modulation following single sideband amplitude modulation

E2B06

**A. Amplitude modulation in which one complete sideband and a portion of the other are transmitted**

ARRL Extra Manual: Page 8-16

Ham Academy Lesson: 6B

Extra Class Questions valid thru 06-30-2016  
Emergency Amateur Radio Club - [www.earchi.org/education](http://www.earchi.org/education)

E2B08

**Which of the following is a common method of transmitting accompanying audio with amateur fast-scan television?**

- A. Frequency-modulated sub-carrier
- B. A separate VHF or UHF audio link
- C. Frequency modulation of the video carrier
- D. All of these choices are correct

E2B08

**D. All of these choices are correct**

ARRL Extra Manual: Page 8-16

Ham Academy Lesson: 6B

Extra Class Questions valid thru 06-30-2016  
Emergency Amateur Radio Club - [www.earchi.org/education](http://www.earchi.org/education)

E2B18

**On which of the following frequencies is one likely to find FM ATV transmissions?**

- A. 14.230 MHz
- B. 29.6 MHz
- C. 52.525 MHz
- D. 1255 MHz

E2B18

**D. 1255 MHz**

ARRL Extra Manual: Page 8-16

Ham Academy Lesson: 6B

Extra Class Questions valid thru 06-30-2016  
Emergency Amateur Radio Club - [www.earchi.org/education](http://www.earchi.org/education)

E2B12

**How are analog SSTV images typically transmitted on the HF bands?**

- A. Video is converted to equivalent Baudot representation
- B. Video is converted to equivalent ASCII representation
- C. Varying tone frequencies representing the video are transmitted using PSK
- D. Varying tone frequencies representing the video are transmitted using single sideband

E2B12

**D. Varying tone frequencies representing the video are transmitted using single sideband**

ARRL Extra Manual: Page 8-17

Ham Academy Lesson: 6B

Extra Class Questions valid thru 06-30-2016  
Emergency Amateur Radio Club - [www.earchi.org/education](http://www.earchi.org/education)

E2B11

**What is the function of the Vertical Interval Signaling (VIS) code transmitted as part of an SSTV transmission?**

- A. To lock the color burst oscillator in color SSTV images
- B. To identify the SSTV mode being used
- C. To provide vertical synchronization
- D. To identify the call sign of the station transmitting

E2B11

**B. To identify the SSTV mode being used**

ARRL Extra Manual: Page 8-18

Ham Academy Lesson: 6B

Extra Class Questions valid thru 06-30-2016  
Emergency Amateur Radio Club - [www.earchi.org/education](http://www.earchi.org/education)

E2B13

**How many lines are commonly used in each frame on an amateur slow-scan color television picture?**

- A. 30 to 60
- B. 60 or 100
- C. 128 or 256
- D. 180 or 360

E2B13

**C. 128 or 256**

ARRL Extra Manual: Page 8-18

Ham Academy Lesson: 6B

Extra Class Questions valid thru 06-30-2016  
Emergency Amateur Radio Club - [www.earchi.org/education](http://www.earchi.org/education)

E2B14

**What aspect of an amateur slow-scan television signal encodes the brightness of the picture?**

- A. Tone frequency
- B. Tone amplitude
- C. Sync amplitude
- D. Sync frequency

E2B14

**A. Tone frequency**

ARRL Extra Manual: Page 8-18

Ham Academy Lesson: 6B

Extra Class Questions valid thru 06-30-2016  
Emergency Amateur Radio Club - [www.earchi.org/education](http://www.earchi.org/education)

E2B15

**What signals SSTV receiving equipment to begin a new picture line?**

- A. Specific tone frequencies
- B. Elapsed time
- C. Specific tone amplitudes
- D. A two-tone signal

E2B15

**A. Specific tone frequencies**

ARRL Extra Manual: Page 8-18

Ham Academy Lesson: 6B

Extra Class Questions valid thru 06-30-2016  
Emergency Amateur Radio Club - [www.earchi.org/education](http://www.earchi.org/education)

E2B17

**What is the approximate bandwidth of a slow-scan TV signal?**

- A. 600 Hz
- B. 3 kHz
- C. 2 MHz
- D. 6 MHz

E2B17

**B. 3 kHz**

ARRL Extra Manual: Page 8-18

Ham Academy Lesson: 6B

Extra Class Questions valid thru 06-30-2016  
Emergency Amateur Radio Club - [www.earchi.org/education](http://www.earchi.org/education)



E2B09

**What hardware, other than a receiver with SSB capability and a suitable computer, is needed to decode SSTV using Digital Radio Mondiale (DRM)?**

- A. A special IF converter
- B. A special front end limiter
- C. A special notch filter to remove synchronization pulses
- D. No other hardware is needed

E2B09

**D. No other hardware is needed**

ARRL Extra Manual: Page 8-19

Ham Academy Lesson: 6B

Extra Class Questions valid thru 06-30-2016

Emergency Amateur Radio Club - [www.earchi.org/education](http://www.earchi.org/education)

E2B10

**Which of the following is an acceptable bandwidth for Digital Radio Mondiale (DRM) based voice or SSTV digital transmissions made on the HF amateur bands?**

- A. 3 KHz
- B. 10 KHz
- C. 15 KHz
- D. 20 KHz

E2B10

**A. 3 KHz**

ARRL Extra Manual: Page 8-19

Ham Academy Lesson: 6B

Extra Class Questions valid thru 06-30-2016

Emergency Amateur Radio Club - [www.earchi.org/education](http://www.earchi.org/education)

E2B19

**What special operating frequency restrictions are imposed on slow scan TV transmissions?**

- A. None; they are allowed on all amateur frequencies
- B. They are restricted to 7.245 MHz, 14.245 MHz, 21.345 MHz, and 28.945 MHz
- C. They are restricted to phone band segments and their bandwidth can be no greater than that of a voice signal of the same modulation type
- D. They are not permitted above 54 MHz

E2B19

**C. They are restricted to phone band segments and their bandwidth can be no greater than that of a voice signal of the same modulation type**

ARRL Extra Manual: Page 8-19

Ham Academy Lesson: 6B

Extra Class Questions valid thru 06-30-2016

Emergency Amateur Radio Club - [www.earchi.org/education](http://www.earchi.org/education)

E4C07

**What does the MDS of a receiver represent?**

- A. The meter display sensitivity
- B. The minimum discernible signal
- C. The multiplex distortion stability
- D. The maximum detectable spectrum

E4C07

**B. The minimum discernible signal**

ARRL Extra Manual: Page 8-19

Ham Academy Lesson: 6B

Extra Class Questions valid thru 06-30-2016

Emergency Amateur Radio Club - [www.earchi.org/education](http://www.earchi.org/education)

E4C04

**What is the definition of the noise figure of a receiver?**

- A. The ratio of atmospheric noise to phase noise
- B. The noise bandwidth in Hertz compared to the theoretical bandwidth of a resistive network
- C. The ratio of thermal noise to atmospheric noise
- D. The ratio in dB of the noise generated by the receiver compared to the theoretical minimum noise

E4C04

**D. The ratio in dB of the noise generated by the receiver compared to the theoretical minimum noise**

ARRL Extra Manual: Page 8-20

Ham Academy Lesson: 6B

Extra Class Questions valid thru 06-30-2016

Emergency Amateur Radio Club - [www.earchi.org/education](http://www.earchi.org/education)

E4C05

**What does a value of -174 dBm/Hz represent with regard to the noise floor of a receiver?**

- A. The minimum detectable signal as a function of receive frequency
- B. The theoretical noise at the input of a perfect receiver at room temperature
- C. The noise figure of a 1 Hz bandwidth receiver
- D. The galactic noise contribution to minimum detectable signal

E4C05

**B. The theoretical noise at the input of a perfect receiver at room temperature**

ARRL Extra Manual: Page 8-20

Ham Academy Lesson: 6C

Extra Class Questions valid thru 06-30-2016

Emergency Amateur Radio Club - [www.earchi.org/education](http://www.earchi.org/education)

E4C06

**A CW receiver with the AGC off has an equivalent input noise power density of -174 dBm/Hz. What would be the level of an unmodulated carrier input to this receiver that would yield an audio output SNR of 0 dB in a 400 Hz noise bandwidth?**

- A. 174 dBm
- B. -164 dBm
- C. -155 dBm
- D. -148 dBm

E4C06

**D. -148 dBm**

ARRL Extra Manual: Page 8-20

Ham Academy Lesson: 6C

Extra Class Questions valid thru 06-30-2016

Emergency Amateur Radio Club - [www.earchi.org/education](http://www.earchi.org/education)

E4C15

**What is the primary source of noise that can be heard from an HF receiver with an antenna connected?**

- A. Detector noise
- B. Induction motor noise
- C. Receiver front-end noise
- D. Atmospheric noise

E4C15

**D. Atmospheric noise**

ARRL Extra Manual: Page 8-20

Ham Academy Lesson: 6C

Extra Class Questions valid thru 06-30-2016

Emergency Amateur Radio Club - [www.earchi.org/education](http://www.earchi.org/education)

E6E05

**Which of the following noise figure values is typical of a low-noise UHF preamplifier?**

- A. 2 dB
- B. -10 dB
- C. 44 dBm
- D. -20 dBm

E6E05

**A. 2 dB**

ARRL Extra Manual: Page 8-20

Ham Academy Lesson: 6C

Extra Class Questions valid thru 06-30-2016  
Emergency Amateur Radio Club - [www.earchi.org/education](http://www.earchi.org/education)

E4C02

**Which of the following portions of a receiver can be effective in eliminating image signal interference?**

- A. A front-end filter or pre-selector
- B. A narrow IF filter
- C. A notch filter
- D. A properly adjusted product detector

E4C02

**A. A front-end filter or pre-selector**

ARRL Extra Manual: Page 8-21

Ham Academy Lesson: 6C

Extra Class Questions valid thru 06-30-2016  
Emergency Amateur Radio Club - [www.earchi.org/education](http://www.earchi.org/education)

E4C08

**How might lowering the noise figure affect receiver performance?**

- A. It would reduce the signal to noise ratio
- B. It would improve weak signal sensitivity
- C. It would reduce bandwidth
- D. It would increase bandwidth

E4C08

**B. It would improve weak signal sensitivity**

ARRL Extra Manual: Page 8-21

Ham Academy Lesson: 6C

Extra Class Questions valid thru 06-30-2016  
Emergency Amateur Radio Club - [www.earchi.org/education](http://www.earchi.org/education)

E4C09

**Which of the following choices is a good reason for selecting a high frequency for the design of the IF in a conventional HF or VHF communications receiver?**

- A. Fewer components in the receiver
- B. Reduced drift
- C. Easier for front-end circuitry to eliminate image responses
- D. Improved receiver noise figure

E4C09

**C. Easier for front-end circuitry to eliminate image responses**

ARRL Extra Manual: Page 8-21

Ham Academy Lesson: 6C

Extra Class Questions valid thru 06-30-2016  
Emergency Amateur Radio Club - [www.earchi.org/education](http://www.earchi.org/education)

E4C14

**On which of the following frequencies might a signal be transmitting which is generating a spurious image signal in a receiver tuned to 14.300 MHz and which uses a 455 kHz IF frequency?**

- A. 13.845 MHz
- B. 14.755 MHz
- C. 14.445 MHz
- D. 15.210 MHz

E4C14

**D. 15.210 MHz**

ARRL Extra Manual: Page 8-21

Ham Academy Lesson: 6C

Extra Class Questions valid thru 06-30-2016  
Emergency Amateur Radio Club - [www.earchi.org/education](http://www.earchi.org/education)

E4D09

**What is the purpose of the preselector in a communications receiver?**

- A. To store often-used frequencies
- B. To provide a range of AGC time constants
- C. To increase rejection of unwanted signals
- D. To allow selection of the optimum RF amplifier device

E4D09

**C. To increase rejection of unwanted signals**

ARRL Extra Manual: Page 8-21

Ham Academy Lesson: 6C

Extra Class Questions valid thru 06-30-2016  
Emergency Amateur Radio Club - [www.earchi.org/education](http://www.earchi.org/education)

E4C10

**Which of the following is a desirable amount of selectivity for an amateur RTTY HF receiver?**

- A. 100 Hz
- B. 300 Hz
- C. 6000 Hz
- D. 2400 Hz

E4C10

**B. 300 Hz**

ARRL Extra Manual: Page 8-22

Ham Academy Lesson: 6C

Extra Class Questions valid thru 06-30-2016  
Emergency Amateur Radio Club - [www.earchi.org/education](http://www.earchi.org/education)

E4C11

**Which of the following is a desirable amount of selectivity for an amateur SSB phone receiver?**

- A. 1 kHz
- B. 2.4 kHz
- C. 4.2 kHz
- D. 4.8 kHz

E4C11

**B. 2.4 kHz**

ARRL Extra Manual: Page 8-22

Ham Academy Lesson: 6C

Extra Class Questions valid thru 06-30-2016  
Emergency Amateur Radio Club - [www.earchi.org/education](http://www.earchi.org/education)

E4C12

**What is an undesirable effect of using too wide a filter bandwidth in the IF section of a receiver?**

- A. Output-offset overshoot
- B. Filter ringing
- C. Thermal-noise distortion
- D. Undesired signals may be heard

E4C12

**D. Undesired signals may be heard**

ARRL Extra Manual: Page 8-22

Ham Academy Lesson: 6C

Extra Class Questions valid thru 06-30-2016  
Emergency Amateur Radio Club - [www.earchi.org/education](http://www.earchi.org/education)

E4C13

**How does a narrow-band roofing filter affect receiver performance?**

- A. It improves sensitivity by reducing front end noise
- B. It improves intelligibility by using low Q circuitry to reduce ringing
- C. It improves dynamic range by attenuating strong signals near the receive frequency
- D. All of these choices are correct

E4C13

**C. It improves dynamic range by attenuating strong signals near the receive frequency**

ARRL Extra Manual: Page 8-22

Ham Academy Lesson: 6C

Extra Class Questions valid thru 06-30-2016  
Emergency Amateur Radio Club - [www.earchi.org/education](http://www.earchi.org/education)

E4D01

**What is meant by the blocking dynamic range of a receiver?**

- A. The difference in dB between the noise floor and the level of an incoming signal which will cause 1 dB of gain compression
- B. The minimum difference in dB between the levels of two FM signals which will cause one signal to block the other
- C. The difference in dB between the noise floor and the third order intercept point
- D. The minimum difference in dB between two signals which produce third order intermodulation products greater than the noise floor

E4D01

**A. The difference in dB between the noise floor and the level of an incoming signal which will cause 1 dB of gain compression**

ARRL Extra Manual: Page 8-23

Ham Academy Lesson: 6C

Extra Class Questions valid thru 06-30-2016  
Emergency Amateur Radio Club - [www.earchi.org/education](http://www.earchi.org/education)

E4D12

**What is the term for the reduction in receiver sensitivity caused by a strong signal near the received frequency?**

- A. Desensitization
- B. Quieting
- C. Cross-modulation interference
- D. Squelch gain rollback

E4D12

**A. Desensitization**

ARRL Extra Manual: Page 8-23

Ham Academy Lesson: 6C

Extra Class Questions valid thru 06-30-2016  
Emergency Amateur Radio Club - [www.earchi.org/education](http://www.earchi.org/education)

E4D13

**Which of the following can cause receiver desensitization?**

- A. Audio gain adjusted too low
- B. Strong adjacent-channel signals
- C. Audio bias adjusted too high
- D. Squelch gain misadjusted

E4D13

**B. Strong adjacent-channel signals**

ARRL Extra Manual: Page 8-23

Ham Academy Lesson: 6C

Extra Class Questions valid thru 06-30-2016

Emergency Amateur Radio Club - [www.earchi.org/education](http://www.earchi.org/education)

E4D14

**Which of the following is a way to reduce the likelihood of receiver desensitization?**

- A. Decrease the RF bandwidth of the receiver
- B. Raise the receiver IF frequency
- C. Increase the receiver front end gain
- D. Switch from fast AGC to slow AGC

E4D14

**A. Decrease the RF bandwidth of the receiver**

ARRL Extra Manual: Page 8-23

Ham Academy Lesson: 6C

Extra Class Questions valid thru 06-30-2016

Emergency Amateur Radio Club - [www.earchi.org/education](http://www.earchi.org/education)

E4D05

**What transmitter frequencies would cause an intermodulation-product signal in a receiver tuned to 146.70 MHz when a nearby station transmits on 146.52 MHz?**

- A. 146.34 MHz and 146.61 MHz
- B. 146.88 MHz and 146.34 MHz
- C. 146.10 MHz and 147.30 MHz
- D. 173.35 MHz and 139.40 MHz

E4D05

**A. 146.34 MHz and 146.61 MHz**

ARRL Extra Manual: Page 8-24

Ham Academy Lesson: 6C

Extra Class Questions valid thru 06-30-2016

Emergency Amateur Radio Club - [www.earchi.org/education](http://www.earchi.org/education)

E4D11

**Why are third-order intermodulation products created within a receiver of particular interest compared to other products?**

- A. The third-order product of two signals which are in the band of interest is also likely to be within the band
- B. The third-order intercept is much higher than other orders
- C. Third-order products are an indication of poor image rejection
- D. Third-order intermodulation produces three products for every input signal within the band of interest

E4D11

**A. The third-order product of two signals which are in the band of interest is also likely to be within the band**

ARRL Extra Manual: Page 8-24

Ham Academy Lesson: 6C

Extra Class Questions valid thru 06-30-2016

Emergency Amateur Radio Club - [www.earchi.org/education](http://www.earchi.org/education)

E4D10

**What does a third-order intercept level of 40 dBm mean with respect to receiver performance?**

- A. Signals less than 40 dBm will not generate audible third-order intermodulation products
- B. The receiver can tolerate signals up to 40 dB above the noise floor without producing third-order intermodulation products
- C. A pair of 40 dBm signals will theoretically generate a third-order intermodulation product with the same level as the input signals
- D. A pair of 1 mW input signals will produce a third-order intermodulation product which is 40 dB stronger than the input signal

E4D10

**C. A pair of 40 dBm signals will theoretically generate a third-order intermodulation product with the same level as the input signals**

ARRL Extra Manual: Page 8-25

Ham Academy Lesson: 6C

Extra Class Questions valid thru 06-30-2016  
Emergency Amateur Radio Club - [www.earchi.org/education](http://www.earchi.org/education)

E4C01

**What is an effect of excessive phase noise in the local oscillator section of a receiver?**

- A. It limits the receiver's ability to receive strong signals
- B. It reduces receiver sensitivity
- C. It decreases receiver third-order intermodulation distortion dynamic range
- D. It can cause strong signals on nearby frequencies to interfere with reception of weak signals

E4C01

**D. It can cause strong signals on nearby frequencies to interfere with reception of weak signals**

ARRL Extra Manual: Page 8-26

Ham Academy Lesson: 6C

Extra Class Questions valid thru 06-30-2016  
Emergency Amateur Radio Club - [www.earchi.org/education](http://www.earchi.org/education)

E4D02

**Which of the following describes two problems caused by poor dynamic range in a communications receiver?**

- A. Cross-modulation of the desired signal and desensitization from strong adjacent signals
- B. Oscillator instability requiring frequent retuning and loss of ability to recover the opposite sideband
- C. Cross-modulation of the desired signal and insufficient audio power to operate the speaker
- D. Oscillator instability and severe audio distortion of all but the strongest received signals

E4D02

**A. Cross-modulation of the desired signal and desensitization from strong adjacent signals**

ARRL Extra Manual: Page 8-26

Ham Academy Lesson: 6C

Extra Class Questions valid thru 06-30-2016  
Emergency Amateur Radio Club - [www.earchi.org/education](http://www.earchi.org/education)

E4C03

**What is the term for the blocking of one FM phone signal by another, stronger FM phone signal?**

- A. Desensitization
- B. Cross-modulation interference
- C. Capture effect
- D. Frequency discrimination

E4C03

**C. Capture effect**

ARRL Extra Manual: Page 8-27

Ham Academy Lesson: 6C

Extra Class Questions valid thru 06-30-2016  
Emergency Amateur Radio Club - [www.earchi.org/education](http://www.earchi.org/education)

E9A01

**Which of the following describes an isotropic antenna?**

- A. A grounded antenna used to measure earth conductivity
- B. A horizontally polarized antenna used to compare Yagi antennas
- C. A theoretical antenna used as a reference for antenna gain
- D. A spacecraft antenna used to direct signals toward the earth

E9A01

**C. A theoretical antenna used as a reference for antenna gain**

ARRL Extra Manual: Page 9-2

Ham Academy Lesson: 7A

Extra Class Questions valid thru 06-30-2016  
Emergency Amateur Radio Club - [www.earchi.org/education](http://www.earchi.org/education)

E9B12

**What is the far-field of an antenna?**

- A. The region of the ionosphere where radiated power is not refracted
- B. The region where radiated power dissipates over a specified time period
- C. The region where radiated field strengths are obstructed by objects of reflection
- D. The region where the shape of the antenna pattern is independent of distance

E9B12

**D. The region where the shape of the antenna pattern is independent of distance**

ARRL Extra Manual: Page 9-2

Ham Academy Lesson: 7A

Extra Class Questions valid thru 06-30-2016  
Emergency Amateur Radio Club - [www.earchi.org/education](http://www.earchi.org/education)

E9A02

**How much gain does a 1/2-wavelength dipole in free space have compared to an isotropic antenna?**

- A. 1.55 dB
- B. 2.15 dB
- C. 3.05 dB
- D. 4.30 dB

E9A02

**B. 2.15 dB**

ARRL Extra Manual: Page 9-3

Ham Academy Lesson: 7A

Extra Class Questions valid thru 06-30-2016  
Emergency Amateur Radio Club - [www.earchi.org/education](http://www.earchi.org/education)

E9A03

**Which of the following antennas has no gain in any direction?**

- A. Quarter-wave vertical
- B. Yagi
- C. Half-wave dipole
- D. Isotropic antenna

E9A03

**D. Isotropic antenna**

ARRL Extra Manual: Page 9-3

Ham Academy Lesson: 7A

Extra Class Questions valid thru 06-30-2016  
Emergency Amateur Radio Club - [www.earchi.org/education](http://www.earchi.org/education)



E9A08

**What is meant by antenna gain?**

- A. The ratio relating the radiated signal strength of an antenna in the direction of maximum radiation to that of a reference antenna
- B. The ratio of the signal in the forward direction to that in the opposite direction
- C. The ratio of the amount of power radiated by an antenna compared to the transmitter output power
- D. The final amplifier gain minus the transmission-line losses, including any phasing lines present

E9A08

**A. The ratio relating the radiated signal strength of an antenna in the direction of maximum radiation to that of a reference antenna**

ARRL Extra Manual: Page 9-3

Ham Academy Lesson: 7A

Extra Class Questions valid thru 06-30-2016

Emergency Amateur Radio Club - [www.earchi.org/education](http://www.earchi.org/education)

E9B07

**How does the total amount of radiation emitted by a directional gain antenna compare with the total amount of radiation emitted from an isotropic antenna, assuming each is driven by the same amount of power?**

- A. The total amount of radiation from the directional antenna is increased by the gain of the antenna
- B. The total amount of radiation from the directional antenna is stronger by its front to back ratio
- C. They are the same
- D. The radiation from the isotropic antenna is 2.15 dB stronger than that from the directional antenna

E9B07

**C. They are the same**

ARRL Extra Manual: Page 9-3

Ham Academy Lesson: 7A

Extra Class Questions valid thru 06-30-2016

Emergency Amateur Radio Club - [www.earchi.org/education](http://www.earchi.org/education)

E9A13

**How much gain does an antenna have compared to a 1/2-wavelength dipole when it has 6 dB gain over an isotropic antenna?**

- A. 3.85 dB
- B. 6.0 dB
- C. 8.15 dB
- D. 2.79 dB

E9A13

**A. 3.85 dB**

ARRL Extra Manual: Page 9-4

Ham Academy Lesson: 7A

Extra Class Questions valid thru 06-30-2016

Emergency Amateur Radio Club - [www.earchi.org/education](http://www.earchi.org/education)

E9A14

**How much gain does an antenna have compared to a 1/2-wavelength dipole when it has 12 dB gain over an isotropic antenna?**

- A. 6.17 dB
- B. 9.85 dB
- C. 12.5 dB
- D. 14.15 dB

E9A14

**B. 9.85 dB**

ARRL Extra Manual: Page 9-4

Ham Academy Lesson: 7A

Extra Class Questions valid thru 06-30-2016

Emergency Amateur Radio Club - [www.earchi.org/education](http://www.earchi.org/education)

E9B08

**How can the approximate beamwidth in a given plane of a directional antenna be determined?**

- A. Note the two points where the signal strength of the antenna is 3 dB less than maximum and compute the angular difference
- B. Measure the ratio of the signal strengths of the radiated power lobes from the front and rear of the antenna
- C. Draw two imaginary lines through the ends of the elements and measure the angle between the lines
- D. Measure the ratio of the signal strengths of the radiated power lobes from the front and side of the antenna

E9B08

**A. Note the two points where the signal strength of the antenna is 3 dB less than maximum and compute the angular difference**

ARRL Extra Manual: Page 9-4

Ham Academy Lesson: 7A

Extra Class Questions valid thru 06-30-2016

Emergency Amateur Radio Club - [www.earchi.org/education](http://www.earchi.org/education)

E9D03

**How does the beamwidth of an antenna vary as the gain is increased?**

- A. It increases geometrically
- B. It increases arithmetically
- C. It is essentially unaffected
- D. It decreases

E9D03

**D. It decreases**

ARRL Extra Manual: Page 9-4

Ham Academy Lesson: 7A

Extra Class Questions valid thru 06-30-2016

Emergency Amateur Radio Club - [www.earchi.org/education](http://www.earchi.org/education)

E9A06

**What is included in the total resistance of an antenna system?**

- A. Radiation resistance plus space impedance
- B. Radiation resistance plus transmission resistance
- C. Transmission-line resistance plus radiation resistance
- D. Radiation resistance plus ohmic resistance

E9A06

**D. Radiation resistance plus ohmic resistance**

ARRL Extra Manual: Page 9-5

Ham Academy Lesson: 7A

Extra Class Questions valid thru 06-30-2016

Emergency Amateur Radio Club - [www.earchi.org/education](http://www.earchi.org/education)

E9A15

**What is meant by the radiation resistance of an antenna?**

- A. The combined losses of the antenna elements and feed line
- B. The specific impedance of the antenna
- C. The value of a resistance that would dissipate the same amount of power as that radiated from an antenna
- D. The resistance in the atmosphere that an antenna must overcome to be able to radiate a signal

E9A15

**C. The value of a resistance that would dissipate the same amount of power as that radiated from an antenna**

ARRL Extra Manual: Page 9-5

Ham Academy Lesson: 7A

Extra Class Questions valid thru 06-30-2016

Emergency Amateur Radio Club - [www.earchi.org/education](http://www.earchi.org/education)

E9B01

**In the antenna radiation pattern shown in Figure E9-1, what is the 3-dB beamwidth?**

- A. 75 degrees
- B. 50 degrees
- C. 25 degrees
- D. 30 degrees

E9B01

**B. 50 degrees**

ARRL Extra Manual: Page 9-5

Ham Academy Lesson: 7A

Extra Class Questions valid thru 06-30-2016  
Emergency Amateur Radio Club - [www.earchi.org/education](http://www.earchi.org/education)

E9B02

**In the antenna radiation pattern shown in Figure E9-1, what is the front-to-back ratio?**

- A. 36 dB
- B. 18 dB
- C. 24 dB
- D. 14 dB

E9B02

**B. 18 dB**

ARRL Extra Manual: Page 9-5

Ham Academy Lesson: 7A

Extra Class Questions valid thru 06-30-2016  
Emergency Amateur Radio Club - [www.earchi.org/education](http://www.earchi.org/education)

E9B03

**In the antenna radiation pattern shown in Figure E9-1, what is the front-to-side ratio?**

- A. 12 dB
- B. 14 dB
- C. 18 dB
- D. 24 dB

E9B03

**B. 14 dB**

ARRL Extra Manual: Page 9-5

Ham Academy Lesson: 7A

Extra Class Questions valid thru 06-30-2016  
Emergency Amateur Radio Club - [www.earchi.org/education](http://www.earchi.org/education)

E9A05

**Which of the following factors may affect the feed point impedance of an antenna?**

- A. Transmission-line length
- B. Antenna height, conductor length/diameter ratio and location of nearby conductive objects
- C. Constant feed point impedance
- D. Sunspot activity and time of day

E9A05

**B. Antenna height, conductor length/diameter ratio and location of nearby conductive objects**

ARRL Extra Manual: Page 9-6

Ham Academy Lesson: 7A

Extra Class Questions valid thru 06-30-2016  
Emergency Amateur Radio Club - [www.earchi.org/education](http://www.earchi.org/education)

E9A10

**How is antenna efficiency calculated?**

- A. (radiation resistance / transmission resistance) x 100%
- B. (radiation resistance / total resistance) x 100%
- C. (total resistance / radiation resistance) x 100%
- D. (effective radiated power / transmitter output) x 100%

E9A10

**B. (radiation resistance / total resistance) x 100%**

ARRL Extra Manual: Page 9-6

Ham Academy Lesson: 7A

Extra Class Questions valid thru 06-30-2016  
Emergency Amateur Radio Club - [www.earchi.org/education](http://www.earchi.org/education)

E9A11

**Which of the following choices is a way to improve the efficiency of a ground-mounted quarter-wave vertical antenna?**

- A. Install a good radial system
- B. Isolate the coax shield from ground
- C. Shorten the radiating element
- D. Reduce the diameter of the radiating element

E9A11

**A. Install a good radial system**

ARRL Extra Manual: Page 9-7

Ham Academy Lesson: 7A

Extra Class Questions valid thru 06-30-2016  
Emergency Amateur Radio Club - [www.earchi.org/education](http://www.earchi.org/education)

E9A09

**What is meant by antenna bandwidth?**

- A. Antenna length divided by the number of elements
- B. The frequency range over which an antenna satisfies a performance requirement
- C. The angle between the half-power radiation points
- D. The angle formed between two imaginary lines drawn through the element ends

E9A09

**B. The frequency range over which an antenna satisfies a performance requirement**

ARRL Extra Manual: Page 9-8

Ham Academy Lesson: 7A

Extra Class Questions valid thru 06-30-2016  
Emergency Amateur Radio Club - [www.earchi.org/education](http://www.earchi.org/education)

E9C07

**What type of antenna pattern over real ground is shown in Figure E9-2?**

- A. Elevation
- B. Azimuth
- C. Radiation resistance
- D. Polarization

E9C07

**A. Elevation**

ARRL Extra Manual: Page 9-8

Ham Academy Lesson: 7A

Extra Class Questions valid thru 06-30-2016  
Emergency Amateur Radio Club - [www.earchi.org/education](http://www.earchi.org/education)

E9C08

**What is the elevation angle of peak response in the antenna radiation pattern shown in Figure E9-2?**

- A. 45 degrees
- B. 75 degrees
- C. 7.5 degrees
- D. 25 degrees

E9C08

**C. 7.5 degrees**

ARRL Extra Manual: Page 9-8

Ham Academy Lesson: 7A

Extra Class Questions valid thru 06-30-2016  
Emergency Amateur Radio Club - [www.earchi.org/education](http://www.earchi.org/education)

E9C09

**What is the front-to-back ratio of the radiation pattern shown in Figure E9-2?**

- A. 15 dB
- B. 28 dB
- C. 3 dB
- D. 24 dB

E9C09

**B. 28 dB**

ARRL Extra Manual: Page 9-8

Ham Academy Lesson: 7A

Extra Class Questions valid thru 06-30-2016  
Emergency Amateur Radio Club - [www.earchi.org/education](http://www.earchi.org/education)

E9C10

**How many elevation lobes appear in the forward direction of the antenna radiation pattern shown in Figure E9-2?**

- A. 4
- B. 3
- C. 1
- D. 7

E9C10

**A. 4**

ARRL Extra Manual: Page 9-8

Ham Academy Lesson: 7A

Extra Class Questions valid thru 06-30-2016  
Emergency Amateur Radio Club - [www.earchi.org/education](http://www.earchi.org/education)

E9A12

**Which of the following factors determines ground losses for a ground-mounted vertical antenna operating in the 3-30 MHz range?**

- A. The standing-wave ratio
- B. Distance from the transmitter
- C. Soil conductivity
- D. Take-off angle

E9A12

**C. Soil conductivity**

ARRL Extra Manual: Page 9-9

Ham Academy Lesson: 7B

Extra Class Questions valid thru 06-30-2016  
Emergency Amateur Radio Club - [www.earchi.org/education](http://www.earchi.org/education)

E9C11

**How is the far-field elevation pattern of a vertically polarized antenna affected by being mounted over seawater versus rocky ground?**

- A. The low-angle radiation decreases
- B. The high-angle radiation increases
- C. Both the high- and low-angle radiation decrease
- D. The low-angle radiation increases

E9C11

**D. The low-angle radiation increases**

ARRL Extra Manual: Page 9-9

Ham Academy Lesson: 7B

Extra Class Questions valid thru 06-30-2016  
Emergency Amateur Radio Club - [www.earchi.org/education](http://www.earchi.org/education)

E9C13

**What is the main effect of placing a vertical antenna over an imperfect ground?**

- A. It causes increased SWR
- B. It changes the impedance angle of the matching network
- C. It reduces low-angle radiation
- D. It reduces losses in the radiating portion of the antenna

E9C13

**C. It reduces low-angle radiation**

ARRL Extra Manual: Page 9-9

Ham Academy Lesson: 7B

Extra Class Questions valid thru 06-30-2016  
Emergency Amateur Radio Club - [www.earchi.org/education](http://www.earchi.org/education)

E3C07

**How does the radiation pattern of a horizontally polarized 3-element beam antenna vary with its height above ground?**

- A. The main lobe takeoff angle increases with increasing height
- B. The main lobe takeoff angle decreases with increasing height
- C. The horizontal beam width increases with height
- D. The horizontal beam width decreases with height

E3C07

**B. The main lobe takeoff angle decreases with increasing height**

ARRL Extra Manual: Page 9-10

Ham Academy Lesson: 7B

Extra Class Questions valid thru 06-30-2016  
Emergency Amateur Radio Club - [www.earchi.org/education](http://www.earchi.org/education)

E3C10

**How does the performance of a horizontally polarized antenna mounted on the side of a hill compare with the same antenna mounted on flat ground?**

- A. The main lobe takeoff angle increases in the downhill direction
- B. The main lobe takeoff angle decreases in the downhill direction
- C. The horizontal beam width decreases in the downhill direction
- D. The horizontal beam width increases in the uphill direction

E3C10

**B. The main lobe takeoff angle decreases in the downhill direction**

ARRL Extra Manual: Page 9-10

Ham Academy Lesson: 7B

Extra Class Questions valid thru 06-30-2016  
Emergency Amateur Radio Club - [www.earchi.org/education](http://www.earchi.org/education)

E9D14

**Which of the following types of conductor would be best for minimizing losses in a station's RF ground system?**

- A. A resistive wire, such as a spark plug wire
- B. A wide flat copper strap
- C. A cable with 6 or 7 18-gauge conductors in parallel
- D. A single 12 or 10-gauge stainless steel wire

E9D14

**B. A wide flat copper strap**

ARRL Extra Manual: Page 9-10

Ham Academy Lesson: 7B

Extra Class Questions valid thru 06-30-2016  
Emergency Amateur Radio Club - [www.earchi.org/education](http://www.earchi.org/education)

E9D08

**What happens to the bandwidth of an antenna as it is shortened through the use of loading coils?**

- A. It is increased
- B. It is decreased
- C. No change occurs
- D. It becomes flat

E9D08

**B. It is decreased**

ARRL Extra Manual: Page 9-11

Ham Academy Lesson: 7B

Extra Class Questions valid thru 06-30-2016  
Emergency Amateur Radio Club - [www.earchi.org/education](http://www.earchi.org/education)

E9D11

**What is the function of a loading coil as used with an HF mobile antenna?**

- A. To increase the SWR bandwidth
- B. To lower the losses
- C. To lower the Q
- D. To cancel capacitive reactance

E9D11

**D. To cancel capacitive reactance**

ARRL Extra Manual: Page 9-11

Ham Academy Lesson: 7B

Extra Class Questions valid thru 06-30-2016  
Emergency Amateur Radio Club - [www.earchi.org/education](http://www.earchi.org/education)

E9D13

**What happens to feed point impedance at the base of a fixed-length HF mobile antenna as the frequency of operation is lowered?**

- A. The radiation resistance decreases and the capacitive reactance decreases
- B. The radiation resistance decreases and the capacitive reactance increases
- C. The radiation resistance increases and the capacitive reactance decreases
- D. The radiation resistance increases and the capacitive reactance increases

E9D13

**B. The radiation resistance decreases and the capacitive reactance increases**

ARRL Extra Manual: Page 9-11

Ham Academy Lesson: 7B

Extra Class Questions valid thru 06-30-2016  
Emergency Amateur Radio Club - [www.earchi.org/education](http://www.earchi.org/education)

E9D15

**Which of the following would provide the best RF ground for your station?**

- A. A 50-ohm resistor connected to ground
- B. An electrically-short connection to a metal water pipe
- C. An electrically-short connection to 3 or 4 interconnected ground rods driven into the Earth
- D. An electrically-short connection to 3 or 4 interconnected ground rods via a series RF choke

E9D15

**C. An electrically-short connection to 3 or 4 interconnected ground rods driven into the Earth**

ARRL Extra Manual: Page 9-11

Ham Academy Lesson: 7B

Extra Class Questions valid thru 06-30-2016  
Emergency Amateur Radio Club - [www.earchi.org/education](http://www.earchi.org/education)

E9D05

**Where should a high-Q loading coil be placed to minimize losses in a shortened vertical antenna?**

- A. Near the center of the vertical radiator
- B. As low as possible on the vertical radiator
- C. As close to the transmitter as possible
- D. At a voltage node

E9D05

**A. Near the center of the vertical radiator**

ARRL Extra Manual: Page 9-12

Ham Academy Lesson: 7B

Extra Class Questions valid thru 06-30-2016  
Emergency Amateur Radio Club - [www.earchi.org/education](http://www.earchi.org/education)

E9D06

**Why should an HF mobile antenna loading coil have a high ratio of reactance to resistance?**

- A. To swamp out harmonics
- B. To maximize losses
- C. To minimize losses
- D. To minimize the Q

E9D06

**C. To minimize losses**

ARRL Extra Manual: Page 9-12

Ham Academy Lesson: 7B

Extra Class Questions valid thru 06-30-2016  
Emergency Amateur Radio Club - [www.earchi.org/education](http://www.earchi.org/education)

E9D09

**What is an advantage of using top loading in a shortened HF vertical antenna?**

- A. Lower Q
- B. Greater structural strength
- C. Higher losses
- D. Improved radiation efficiency

E9D09

**D. Improved radiation efficiency**

ARRL Extra Manual: Page 9-13

Ham Academy Lesson: 7B

Extra Class Questions valid thru 06-30-2016  
Emergency Amateur Radio Club - [www.earchi.org/education](http://www.earchi.org/education)



E9D12

**What is one advantage of using a trapped antenna?**

- A. It has high directivity in the higher-frequency bands
- B. It has high gain
- C. It minimizes harmonic radiation
- D. It may be used for multiband operation

E9D12

**D. It may be used for multiband operation**

ARRL Extra Manual: Page 9-13

Ham Academy Lesson: 7B

Extra Class Questions valid thru 06-30-2016  
Emergency Amateur Radio Club - [www.earchi.org/education](http://www.earchi.org/education)

E9A07

**What is a folded dipole antenna?**

- A. A dipole one-quarter wavelength long
- B. A type of ground-plane antenna
- C. A dipole constructed from one wavelength of wire forming a very thin loop
- D. A dipole configured to provide forward gain

E9A07

**C. A dipole constructed from one wavelength of wire forming a very thin loop**

ARRL Extra Manual: Page 9-14

Ham Academy Lesson: 7B

Extra Class Questions valid thru 06-30-2016  
Emergency Amateur Radio Club - [www.earchi.org/education](http://www.earchi.org/education)

E9D07

**What is a disadvantage of using a multiband trapped antenna?**

- A. It might radiate harmonics
- B. It radiates the harmonics and fundamental equally well
- C. It is too sharply directional at lower frequencies
- D. It must be neutralized

E9D07

**A. It might radiate harmonics**

ARRL Extra Manual: Page 9-14

Ham Academy Lesson: 7B

Extra Class Questions valid thru 06-30-2016  
Emergency Amateur Radio Club - [www.earchi.org/education](http://www.earchi.org/education)

E9D10

**What is the approximate feed point impedance at the center of a two-wire folded dipole antenna?**

- A. 300 ohms
- B. 72 ohms
- C. 50 ohms
- D. 450 ohms

E9D10

**A. 300 ohms**

ARRL Extra Manual: Page 9-15

Ham Academy Lesson: 7B

Extra Class Questions valid thru 06-30-2016  
Emergency Amateur Radio Club - [www.earchi.org/education](http://www.earchi.org/education)

E9C04

**Which of the following describes a basic unterminated rhombic antenna?**

- A. Unidirectional; four-sides, each side one quarter-wavelength long; terminated in a resistance equal to its characteristic impedance
- B. Bidirectional; four-sides, each side one or more wavelengths long; open at the end opposite the transmission line connection
- C. Four-sides; an LC network at each corner except for the transmission connection;
- D. Four-sides, each of a different physical length

E9C04

**B. Bidirectional; four-sides, each side one or more wavelengths long; open at the end opposite the transmission line connection**

ARRL Extra Manual: Page 9-16

Ham Academy Lesson: 7B

Extra Class Questions valid thru 06-30-2016

Emergency Amateur Radio Club - [www.earchi.org/education](http://www.earchi.org/education)

E9C06

**What is the effect of a terminating resistor on a rhombic antenna?**

- A. It reflects the standing waves on the antenna elements back to the transmitter
- B. It changes the radiation pattern from bidirectional to unidirectional
- C. It changes the radiation pattern from horizontal to vertical polarization
- D. It decreases the ground loss

E9C06

**B. It changes the radiation pattern from bidirectional to unidirectional**

ARRL Extra Manual: Page 9-16

Ham Academy Lesson: 7B

Extra Class Questions valid thru 06-30-2016

Emergency Amateur Radio Club - [www.earchi.org/education](http://www.earchi.org/education)

E9C05

**What are the disadvantages of a terminated rhombic antenna for the HF bands?**

- A. The antenna has a very narrow operating bandwidth
- B. The antenna produces a circularly polarized signal
- C. The antenna requires a large physical area and 4 separate supports
- D. The antenna is more sensitive to man-made static than any other type

E9C05

**C. The antenna requires a large physical area and 4 separate supports**

ARRL Extra Manual: Page 9-17

Ham Academy Lesson: 7B

Extra Class Questions valid thru 06-30-2016

Emergency Amateur Radio Club - [www.earchi.org/education](http://www.earchi.org/education)

E9C12

**When constructing a Beverage antenna, which of the following factors should be included in the design to achieve good performance at the desired frequency?**

- A. Its overall length must not exceed 1/4 wavelength
- B. It must be mounted more than 1 wavelength above ground
- C. It should be configured as a four-sided loop
- D. It should be one or more wavelengths long

E9C12

**D. It should be one or more wavelengths long**

ARRL Extra Manual: Page 9-17

Ham Academy Lesson: 7B

Extra Class Questions valid thru 06-30-2016

Emergency Amateur Radio Club - [www.earchi.org/education](http://www.earchi.org/education)

E9C03

**What is the radiation pattern of two 1/4-wavelength vertical antennas spaced 1/2-wavelength apart and fed in phase?**

- A. Omnidirectional
- B. A cardioid
- C. A Figure-8 broadside to the axis of the array
- D. A Figure-8 end-fire along the axis of the array

E9C03

**C. A Figure-8 broadside to the axis of the array**

ARRL Extra Manual: Page 9-18

Ham Academy Lesson: 7B

Extra Class Questions valid thru 06-30-2016  
Emergency Amateur Radio Club - [www.earchi.org/education](http://www.earchi.org/education)

E9C01

**What is the radiation pattern of two 1/4-wavelength vertical antennas spaced 1/2-wavelength apart and fed 180 degrees out of phase?**

- A. A cardioid
- B. Omnidirectional
- C. A figure-8 broadside to the axis of the array
- D. A figure-8 oriented along the axis of the array

E9C01

**D. A figure-8 oriented along the axis of the array**

ARRL Extra Manual: Page 9-20

Ham Academy Lesson: 7B

Extra Class Questions valid thru 06-30-2016  
Emergency Amateur Radio Club - [www.earchi.org/education](http://www.earchi.org/education)

E9C02

**What is the radiation pattern of two 1/4-wavelength vertical antennas spaced 1/4-wavelength apart and fed 90 degrees out of phase?**

- A. A cardioid
- B. A figure-8 end-fire along the axis of the array
- C. A figure-8 broadside to the axis of the array
- D. Omnidirectional

E9C02

**A. A cardioid**

ARRL Extra Manual: Page 9-20

Ham Academy Lesson: 7B

Extra Class Questions valid thru 06-30-2016  
Emergency Amateur Radio Club - [www.earchi.org/education](http://www.earchi.org/education)

E9E12

**What is the primary purpose of a phasing line when used with an antenna having multiple driven elements?**

- A. It ensures that each driven element operates in concert with the others to create the desired antenna pattern
- B. It prevents reflected power from traveling back down the feed line and causing harmonic radiation from the transmitter
- C. It allows single-band antennas to operate on other bands
- D. It makes sure the antenna has a low-angle radiation pattern

E9E12

**A. It ensures that each driven element operates in concert with the others to create the desired antenna pattern**

ARRL Extra Manual: Page 9-20

Ham Academy Lesson: 7B

Extra Class Questions valid thru 06-30-2016  
Emergency Amateur Radio Club - [www.earchi.org/education](http://www.earchi.org/education)

E9E13

**What is the purpose of a Wilkinson divider?**

- A. It divides the operating frequency of a transmitter signal so it can be used on a lower frequency band
- B. It is used to feed high-impedance antennas from a low-impedance source
- C. It divides power equally among multiple loads while preventing changes in one load from disturbing power flow to the others
- D. It is used to feed low-impedance loads from a high-impedance source

E9E13

**C. It divides power equally among multiple loads while preventing changes in one load from disturbing power flow to the others**

ARRL Extra Manual: Page 9-20

Ham Academy Lesson: 7B

Extra Class Questions valid thru 06-30-2016  
Emergency Amateur Radio Club - [www.earchi.org/education](http://www.earchi.org/education)

E9H04

**What term describes station output, including the transmitter, antenna and everything in between, when considering transmitter power and system gains and losses?**

- A. Power factor
- B. Half-power bandwidth
- C. Effective radiated power
- D. Apparent power

E9H04

**C. Effective radiated power**

ARRL Extra Manual: Page 9-20

Ham Academy Lesson: 7C

Extra Class Questions valid thru 06-30-2016  
Emergency Amateur Radio Club - [www.earchi.org/education](http://www.earchi.org/education)

E9H01

**What is the effective radiated power relative to a dipole of a repeater station with 150 watts transmitter power output, 2-dB feed line loss, 2.2-dB duplexer loss and 7-dBd antenna gain?**

- A. 1977 watts
- B. 78.7 watts
- C. 420 watts
- D. 286 watts

E9H01

**D. 286 watts**

ARRL Extra Manual: Page 9-21

Ham Academy Lesson: 7C

Extra Class Questions valid thru 06-30-2016  
Emergency Amateur Radio Club - [www.earchi.org/education](http://www.earchi.org/education)

E9H02

**What is the effective radiated power relative to a dipole of a repeater station with 200 watts transmitter power output, 4-dB feed line loss, 3.2-dB duplexer loss, 0.8-dB circulator loss and 10-dBd antenna gain?**

- A. 317 watts
- B. 2000 watts
- C. 126 watts
- D. 300 watts

E9H02

**A. 317 watts**

ARRL Extra Manual: Page 9-21

Ham Academy Lesson: 7C

Extra Class Questions valid thru 06-30-2016  
Emergency Amateur Radio Club - [www.earchi.org/education](http://www.earchi.org/education)

E9H03

**What is the effective isotropic radiated power of a repeater station with 200 watts transmitter power output, 2-dB feed line loss, 2.8-dB duplexer loss, 1.2-dB circulator loss and 7-dBi antenna gain?**

- A. 159 watts
- B. 252 watts
- C. 632 watts
- D. 63.2 watts

E9H03

**B. 252 watts**

ARRL Extra Manual: Page 9-22

Ham Academy Lesson: 7C

Extra Class Questions valid thru 06-30-2016  
Emergency Amateur Radio Club - [www.earchi.org/education](http://www.earchi.org/education)

E9D01

**How does the gain of an ideal parabolic dish antenna change when the operating frequency is doubled?**

- A. Gain does not change
- B. Gain is multiplied by 0.707
- C. Gain increases by 6 dB
- D. Gain increases by 3 dB

E9D01

**C. Gain increases by 6 dB**

ARRL Extra Manual: Page 9-23

Ham Academy Lesson: 7C

Extra Class Questions valid thru 06-30-2016  
Emergency Amateur Radio Club - [www.earchi.org/education](http://www.earchi.org/education)

E9D02

**How can linearly polarized Yagi antennas be used to produce circular polarization?**

- A. Stack two Yagis, fed 90 degrees out of phase, to form an array with the respective elements in parallel planes
- B. Stack two Yagis, fed in phase, to form an array with the respective elements in parallel planes
- C. Arrange two Yagis perpendicular to each other with the driven elements at the same point on the boom and fed 90 degrees out of phase
- D. Arrange two Yagis collinear to each other, with the driven elements fed 180 degrees out of phase

E9D02

**C. Arrange two Yagis perpendicular to each other with the driven elements at the same point on the boom and fed 90 degrees out of phase**

ARRL Extra Manual: Page 9-23

Ham Academy Lesson: 7C

Extra Class Questions valid thru 06-30-2016  
Emergency Amateur Radio Club - [www.earchi.org/education](http://www.earchi.org/education)

E9D04

**Why is it desirable for a ground-mounted satellite communications antenna system to be able to move in both azimuth and elevation?**

- A. In order to track the satellite as it orbits the Earth
- B. So the antenna can be pointed away from interfering signals
- C. So the antenna can be positioned to cancel the effects of Faraday rotation
- D. To rotate antenna polarization to match that of the satellite

E9D04

**A. In order to track the satellite as it orbits the Earth**

ARRL Extra Manual: Page 9-23

Ham Academy Lesson: 7C

Extra Class Questions valid thru 06-30-2016  
Emergency Amateur Radio Club - [www.earchi.org/education](http://www.earchi.org/education)

E9H09

**Which of the following describes the construction of a receiving loop antenna?**

- A. A large circularly-polarized antenna
- B. A small coil of wire tightly wound around a toroidal ferrite core
- C. One or more turns of wire wound in the shape of a large open coil
- D. A vertical antenna coupled to a feed line through an inductive loop of wire

E9H09

**C. One or more turns of wire wound in the shape of a large open coil**

ARRL Extra Manual: Page 9-23

Ham Academy Lesson: 7C

Extra Class Questions valid thru 06-30-2016  
Emergency Amateur Radio Club - [www.earchi.org/education](http://www.earchi.org/education)

E9H10

**How can the output voltage of a multi-turn receiving loop antenna be increased?**

- A. By reducing the permeability of the loop shield
- B. By increasing the number of wire turns in the loop and reducing the area of the loop structure
- C. By winding adjacent turns in opposing directions
- D. By increasing either the number of wire turns in the loop or the area of the loop structure or both

E9H10

**D. By increasing either the number of wire turns in the loop or the area of the loop structure or both**

ARRL Extra Manual: Page 9-24

Ham Academy Lesson: 7C

Extra Class Questions valid thru 06-30-2016  
Emergency Amateur Radio Club - [www.earchi.org/education](http://www.earchi.org/education)

E9H05

**What is the main drawback of a wire-loop antenna for direction finding?**

- A. It has a bidirectional pattern
- B. It is non-rotatable
- C. It receives equally well in all directions
- D. It is practical for use only on VHF bands

E9H05

**A. It has a bidirectional pattern**

ARRL Extra Manual: Page 9-25

Ham Academy Lesson: 7C

Extra Class Questions valid thru 06-30-2016  
Emergency Amateur Radio Club - [www.earchi.org/education](http://www.earchi.org/education)

E9H06

**What is the triangulation method of direction finding?**

- A. The geometric angle of sky waves from the source are used to determine its position
- B. A fixed receiving station plots three headings from the signal source on a map
- C. Antenna headings from several different receiving locations are used to locate the signal source
- D. A fixed receiving station uses three different antennas to plot the location of the signal source

E9H06

**C. Antenna headings from several different receiving locations are used to locate the signal source**

ARRL Extra Manual: Page 9-25

Ham Academy Lesson: 7C

Extra Class Questions valid thru 06-30-2016  
Emergency Amateur Radio Club - [www.earchi.org/education](http://www.earchi.org/education)

E9H07

**Why is it advisable to use an RF attenuator on a receiver being used for direction finding?**

- A. It narrows the bandwidth of the received signal to improve signal to noise ratio
- B. It compensates for the effects of an isotropic antenna, thereby improving directivity
- C. It reduces loss of received signals caused by antenna pattern nulls, thereby increasing sensitivity
- D. It prevents receiver overload which could make it difficult to determine peaks or nulls

E9H07

**D. It prevents receiver overload which could make it difficult to determine peaks or nulls**

ARRL Extra Manual: Page 9-25

Ham Academy Lesson: 7C

Extra Class Questions valid thru 06-30-2016  
Emergency Amateur Radio Club - [www.earchi.org/education](http://www.earchi.org/education)

E9H12

**What is an advantage of using a shielded loop antenna for direction finding?**

- A. It automatically cancels ignition noise pickup in mobile installations
- B. It is electro-statically balanced against ground, giving better nulls
- C. It eliminates tracking errors caused by strong out-of-band signals
- D. It allows stations to communicate without giving away their position

E9H12

**B. It is electro-statically balanced against ground, giving better nulls**

ARRL Extra Manual: Page 9-25

Ham Academy Lesson: 7C

Extra Class Questions valid thru 06-30-2016  
Emergency Amateur Radio Club - [www.earchi.org/education](http://www.earchi.org/education)

E9H08

**What is the function of a sense antenna?**

- A. It modifies the pattern of a DF antenna array to provide a null in one direction
- B. It increases the sensitivity of a DF antenna array
- C. It allows DF antennas to receive signals at different vertical angles
- D. It provides diversity reception that cancels multipath signals

E9H08

**A. It modifies the pattern of a DF antenna array to provide a null in one direction**

ARRL Extra Manual: Page 9-26

Ham Academy Lesson: 7C

Extra Class Questions valid thru 06-30-2016  
Emergency Amateur Radio Club - [www.earchi.org/education](http://www.earchi.org/education)

E9H11

**What characteristic of a cardioid-pattern antenna is useful for direction finding?**

- A. A very sharp peak
- B. A very sharp single null
- C. Broad band response
- D. High-radiation angle

E9H11

**B. A very sharp single null**

ARRL Extra Manual: Page 9-26

Ham Academy Lesson: 7C

Extra Class Questions valid thru 06-30-2016  
Emergency Amateur Radio Club - [www.earchi.org/education](http://www.earchi.org/education)

E9A04

**Why would one need to know the feed point impedance of an antenna?**

- A. To match impedances in order to minimize standing wave ratio on the transmission line
- B. To measure the near-field radiation density from a transmitting antenna
- C. To calculate the front-to-side ratio of the antenna
- D. To calculate the front-to-back ratio of the antenna

E9A04

**A. To match impedances in order to minimize standing wave ratio on the transmission line**

ARRL Extra Manual: Page 9-27

Ham Academy Lesson: 7C

Extra Class Questions valid thru 06-30-2016  
Emergency Amateur Radio Club - [www.earchi.org/education](http://www.earchi.org/education)

E9E01

**What system matches a high-impedance transmission line to a lower impedance antenna by connecting the line to the driven element in two places spaced a fraction of a wavelength each side of element center?**

- A. The gamma matching system
- B. The delta matching system
- C. The omega matching system
- D. The stub matching system

E9E01

**B. The delta matching system**

ARRL Extra Manual: Page 9-28

Ham Academy Lesson: 7C

Extra Class Questions valid thru 06-30-2016  
Emergency Amateur Radio Club - [www.earchi.org/education](http://www.earchi.org/education)

E9E02

**What is the name of an antenna matching system that matches an unbalanced feed line to an antenna by feeding the driven element both at the center of the element and at a fraction of a wavelength to one side of center?**

- A. The gamma match
- B. The delta match
- C. The epsilon match
- D. The stub match

E9E02

**A. The gamma match**

ARRL Extra Manual: Page 9-28

Ham Academy Lesson: 7C

Extra Class Questions valid thru 06-30-2016  
Emergency Amateur Radio Club - [www.earchi.org/education](http://www.earchi.org/education)

E9E04

**What is the purpose of the series capacitor in a gamma-type antenna matching network?**

- A. To provide DC isolation between the feed line and the antenna
- B. To cancel the inductive reactance of the matching network
- C. To provide a rejection notch to prevent the radiation of harmonics
- D. To transform the antenna impedance to a higher value

E9E04

**B. To cancel the inductive reactance of the matching network**

ARRL Extra Manual: Page 9-28

Ham Academy Lesson: 7C

Extra Class Questions valid thru 06-30-2016  
Emergency Amateur Radio Club - [www.earchi.org/education](http://www.earchi.org/education)



E9E09

**Which of these matching systems is an effective method of connecting a 50-ohm coaxial cable feed line to a grounded tower so it can be used as a vertical antenna?**

- A. Double-bazooka match
- B. Hairpin match
- C. Gamma match
- D. All of these choices are correct

E9E09

**C. Gamma match**

ARRL Extra Manual: Page 9-28

Ham Academy Lesson: 7C

Extra Class Questions valid thru 06-30-2016  
Emergency Amateur Radio Club - [www.earchi.org/education](http://www.earchi.org/education)

E9E03

**What is the name of the matching system that uses a section of transmission line connected in parallel with the feed line at the feed point?**

- A. The gamma match
- B. The delta match
- C. The omega match
- D. The stub match

E9E03

**D. The stub match**

ARRL Extra Manual: Page 9-29

Ham Academy Lesson: 7C

Extra Class Questions valid thru 06-30-2016  
Emergency Amateur Radio Club - [www.earchi.org/education](http://www.earchi.org/education)

E9E05

**How must the driven element in a 3-element Yagi be tuned to use a hairpin matching system?**

- A. The driven element reactance must be capacitive
- B. The driven element reactance must be inductive
- C. The driven element resonance must be lower than the operating frequency
- D. The driven element radiation resistance must be higher than the characteristic impedance of the transmission line

E9E05

**A. The driven element reactance must be capacitive**

ARRL Extra Manual: Page 9-29

Ham Academy Lesson: 7C

Extra Class Questions valid thru 06-30-2016  
Emergency Amateur Radio Club - [www.earchi.org/education](http://www.earchi.org/education)

E9E06

**What is the equivalent lumped-constant network for a hairpin matching system on a 3-element Yagi?**

- A. Pi network
- B. Pi-L network
- C. L network
- D. Parallel-resonant tank

E9E06

**C. L network**

ARRL Extra Manual: Page 9-29

Ham Academy Lesson: 7C

Extra Class Questions valid thru 06-30-2016  
Emergency Amateur Radio Club - [www.earchi.org/education](http://www.earchi.org/education)

E9E11

**What is an effective way of matching a feed line to a VHF or UHF antenna when the impedances of both the antenna and feed line are unknown?**

- A. Use a 50-ohm 1:1 balun between the antenna and feed line
- B. Use the "universal stub" matching technique
- C. Connect a series-resonant LC network across the antenna feed terminals
- D. Connect a parallel-resonant LC network across the antenna feed terminals

E9E11

**B. Use the "universal stub" matching technique**

ARRL Extra Manual: Page 9-29

Ham Academy Lesson: 7C

Extra Class Questions valid thru 06-30-2016

Emergency Amateur Radio Club - [www.earchi.org/education](http://www.earchi.org/education)

E9F01

**What is the velocity factor of a transmission line?**

- A. The ratio of the characteristic impedance of the line to the terminating impedance
- B. The index of shielding for coaxial cable
- C. The velocity of the wave in the transmission line multiplied by the velocity of light in a vacuum
- D. The velocity of the wave in the transmission line divided by the velocity of light in a vacuum

E9F01

**D. The velocity of the wave in the transmission line divided by the velocity of light in a vacuum**

ARRL Extra Manual: Page 9-31

Ham Academy Lesson: 7C

Extra Class Questions valid thru 06-30-2016

Emergency Amateur Radio Club - [www.earchi.org/education](http://www.earchi.org/education)

E9F02

**Which of the following determines the velocity factor of a transmission line?**

- A. The termination impedance
- B. The line length
- C. Dielectric materials used in the line
- D. The center conductor resistivity

E9F02

**C. Dielectric materials used in the line**

ARRL Extra Manual: Page 9-31

Ham Academy Lesson: 7C

Extra Class Questions valid thru 06-30-2016

Emergency Amateur Radio Club - [www.earchi.org/education](http://www.earchi.org/education)

E9F03

**Why is the physical length of a coaxial cable transmission line shorter than its electrical length?**

- A. Skin effect is less pronounced in the coaxial cable
- B. The characteristic impedance is higher in a parallel feed line
- C. The surge impedance is higher in a parallel feed line
- D. Electrical signals move more slowly in a coaxial cable than in air

E9F03

**D. Electrical signals move more slowly in a coaxial cable than in air**

ARRL Extra Manual: Page 9-31

Ham Academy Lesson: 7C

Extra Class Questions valid thru 06-30-2016

Emergency Amateur Radio Club - [www.earchi.org/education](http://www.earchi.org/education)

E9F04

**What is the typical velocity factor for a coaxial cable with solid polyethylene dielectric?**

- A. 2.70
- B. 0.66
- C. 0.30
- D. 0.10

E9F04

**B. 0.66**

ARRL Extra Manual: Page 9-31

Ham Academy Lesson: 7C

Extra Class Questions valid thru 06-30-2016  
Emergency Amateur Radio Club - [www.earchi.org/education](http://www.earchi.org/education)

E9F08

**What is the term for the ratio of the actual speed at which a signal travels through a transmission line to the speed of light in a vacuum?**

- A. Velocity factor
- B. Characteristic impedance
- C. Surge impedance
- D. Standing wave ratio

E9F08

**A. Velocity factor**

ARRL Extra Manual: Page 9-31

Ham Academy Lesson: 7C

Extra Class Questions valid thru 06-30-2016  
Emergency Amateur Radio Club - [www.earchi.org/education](http://www.earchi.org/education)

E9F05

**What is the approximate physical length of a solid polyethylene dielectric coaxial transmission line that is electrically one-quarter wavelength long at 14.1 MHz?**

- A. 20 meters
- B. 2.3 meters
- C. 3.5 meters
- D. 0.2 meters

E9F05

**C. 3.5 meters**

ARRL Extra Manual: Page 9-32

Ham Academy Lesson: 7C

Extra Class Questions valid thru 06-30-2016  
Emergency Amateur Radio Club - [www.earchi.org/education](http://www.earchi.org/education)

E9F06

**What is the approximate physical length of an air-insulated, parallel conductor transmission line that is electrically one-half wavelength long at 14.10 MHz?**

- A. 15 meters
- B. 20 meters
- C. 10 meters
- D. 71 meters

E9F06

**C. 10 meters**

ARRL Extra Manual: Page 9-32

Ham Academy Lesson: 7C

Extra Class Questions valid thru 06-30-2016  
Emergency Amateur Radio Club - [www.earchi.org/education](http://www.earchi.org/education)

E9F07

**How does ladder line compare to small-diameter coaxial cable such as RG-58 at 50 MHz?**

- A. Lower loss
- B. Higher SWR
- C. Smaller reflection coefficient
- D. Lower velocity factor

E9F07

**A. Lower loss**

ARRL Extra Manual: Page 9-32

Ham Academy Lesson: 7C

Extra Class Questions valid thru 06-30-2016  
Emergency Amateur Radio Club - [www.earchi.org/education](http://www.earchi.org/education)

E9F09

**What is the approximate physical length of a solid polyethylene dielectric coaxial transmission line that is electrically one-quarter wavelength long at 7.2 MHz?**

- A. 10 meters
- B. 6.9 meters
- C. 24 meters
- D. 50 meters

E9F09

**B. 6.9 meters**

ARRL Extra Manual: Page 9-32

Ham Academy Lesson: 7C

Extra Class Questions valid thru 06-30-2016  
Emergency Amateur Radio Club - [www.earchi.org/education](http://www.earchi.org/education)

E9F16

**Which of the following is a significant difference between foam-dielectric coaxial cable and solid-dielectric cable, assuming all other parameters are the same?**

- A. Reduced safe operating voltage limits
- B. Reduced losses per unit of length
- C. Higher velocity factor
- D. All of these choices are correct

E9F16

**D. All of these choices are correct**

ARRL Extra Manual: Page 9-32

Ham Academy Lesson: 7C

Extra Class Questions valid thru 06-30-2016  
Emergency Amateur Radio Club - [www.earchi.org/education](http://www.earchi.org/education)

E9E07

**What term best describes the interactions at the load end of a mismatched transmission line?**

- A. Characteristic impedance
- B. Reflection coefficient
- C. Velocity factor
- D. Dielectric constant

E9E07

**B. Reflection coefficient**

ARRL Extra Manual: Page 9-33

Ham Academy Lesson: 7C

Extra Class Questions valid thru 06-30-2016  
Emergency Amateur Radio Club - [www.earchi.org/education](http://www.earchi.org/education)

E9E08

**Which of the following measurements is characteristic of a mismatched transmission line?**

- A. An SWR less than 1:1
- B. A reflection coefficient greater than 1
- C. A dielectric constant greater than 1
- D. An SWR greater than 1:1

E9E08

**D. An SWR greater than 1:1**

ARRL Extra Manual: Page 9-33

Ham Academy Lesson: 7C

Extra Class Questions valid thru 06-30-2016  
Emergency Amateur Radio Club - [www.earchi.org/education](http://www.earchi.org/education)

E4B06

**How much power is being absorbed by the load when a directional power meter connected between a transmitter and a terminating load reads 100 watts forward power and 25 watts reflected power?**

- A. 100 watts
- B. 125 watts
- C. 25 watts
- D. 75 watts

E4B06

**D. 75 watts**

ARRL Extra Manual: Page 9-34

Ham Academy Lesson: 7D

Extra Class Questions valid thru 06-30-2016  
Emergency Amateur Radio Club - [www.earchi.org/education](http://www.earchi.org/education)

E4B09

**What is indicated if the current reading on an RF ammeter placed in series with the antenna feed line of a transmitter increases as the transmitter is tuned to resonance?**

- A. There is possibly a short to ground in the feed line
- B. The transmitter is not properly neutralized
- C. There is an impedance mismatch between the antenna and feed line
- D. There is more power going into the antenna

E4B09

**D. There is more power going into the antenna**

ARRL Extra Manual: Page 9-34

Ham Academy Lesson: 7D

Extra Class Questions valid thru 06-30-2016  
Emergency Amateur Radio Club - [www.earchi.org/education](http://www.earchi.org/education)

E9G01

**Which of the following can be calculated using a Smith chart?**

- A. Impedance along transmission lines
- B. Radiation resistance
- C. Antenna radiation pattern
- D. Radio propagation

E9G01

**A. Impedance along transmission lines**

ARRL Extra Manual: Page 9-35

Ham Academy Lesson: 7D

Extra Class Questions valid thru 06-30-2016  
Emergency Amateur Radio Club - [www.earchi.org/education](http://www.earchi.org/education)

E9G03

**Which of the following is often determined using a Smith chart?**

- A. Beam headings and radiation patterns
- B. Satellite azimuth and elevation bearings
- C. Impedance and SWR values in transmission lines
- D. Trigonometric functions

E9G03

**C. Impedance and SWR values in transmission lines**

ARRL Extra Manual: Page 9-35

Ham Academy Lesson: 7D

Extra Class Questions valid thru 06-30-2016  
Emergency Amateur Radio Club - [www.earchi.org/education](http://www.earchi.org/education)

E9G05

**What type of chart is shown in Figure E9-3?**

- A. Smith chart
- B. Free-space radiation directivity chart
- C. Elevation angle radiation pattern chart
- D. Azimuth angle radiation pattern chart

E9G05

**A. Smith chart**

ARRL Extra Manual: Page 9-35

Ham Academy Lesson: 7D

Extra Class Questions valid thru 06-30-2016  
Emergency Amateur Radio Club - [www.earchi.org/education](http://www.earchi.org/education)

E9G07

**On the Smith chart shown in Figure E9-3, what is the only straight line shown?**

- A. The reactance axis
- B. The current axis
- C. The voltage axis
- D. The resistance axis

E9G07

**D. The resistance axis**

ARRL Extra Manual: Page 9-35

Ham Academy Lesson: 7D

Extra Class Questions valid thru 06-30-2016  
Emergency Amateur Radio Club - [www.earchi.org/education](http://www.earchi.org/education)

E9G02

**What type of coordinate system is used in a Smith chart?**

- A. Voltage circles and current arcs
- B. Resistance circles and reactance arcs
- C. Voltage lines and current chords
- D. Resistance lines and reactance chords

E9G02

**B. Resistance circles and reactance arcs**

ARRL Extra Manual: Page 9-37

Ham Academy Lesson: 7D

Extra Class Questions valid thru 06-30-2016  
Emergency Amateur Radio Club - [www.earchi.org/education](http://www.earchi.org/education)

E9G04

**What are the two families of circles and arcs that make up a Smith chart?**

- A. Resistance and voltage
- B. Reactance and voltage
- C. Resistance and reactance
- D. Voltage and impedance

E9G04

**C. Resistance and reactance**

ARRL Extra Manual: Page 9-37

Ham Academy Lesson: 7D

Extra Class Questions valid thru 06-30-2016  
Emergency Amateur Radio Club - [www.earchi.org/education](http://www.earchi.org/education)

E9G06

**On the Smith chart shown in Figure E9-3, what is the name for the large outer circle on which the reactance arcs terminate?**

- A. Prime axis
- B. Reactance axis
- C. Impedance axis
- D. Polar axis

E9G06

**B. Reactance axis**

ARRL Extra Manual: Page 9-37

Ham Academy Lesson: 7D

Extra Class Questions valid thru 06-30-2016  
Emergency Amateur Radio Club - [www.earchi.org/education](http://www.earchi.org/education)

E9G08

**What is the process of normalization with regard to a Smith chart?**

- A. Reassigning resistance values with regard to the reactance axis
- B. Reassigning reactance values with regard to the resistance axis
- C. Reassigning impedance values with regard to the prime center
- D. Reassigning prime center with regard to the reactance axis

E9G08

**C. Reassigning impedance values with regard to the prime center**

ARRL Extra Manual: Page 9-37

Ham Academy Lesson: 7D

Extra Class Questions valid thru 06-30-2016  
Emergency Amateur Radio Club - [www.earchi.org/education](http://www.earchi.org/education)

E9G09

**What third family of circles is often added to a Smith chart during the process of solving problems?**

- A. Standing-wave ratio circles
- B. Antenna-length circles
- C. Coaxial-length circles
- D. Radiation-pattern circles

E9G09

**A. Standing-wave ratio circles**

ARRL Extra Manual: Page 9-37

Ham Academy Lesson: 7D

Extra Class Questions valid thru 06-30-2016  
Emergency Amateur Radio Club - [www.earchi.org/education](http://www.earchi.org/education)

E9G10

**What do the arcs on a Smith chart represent?**

- A. Frequency
- B. SWR
- C. Points with constant resistance
- D. Points with constant reactance

E9G10

**D. Points with constant reactance**

ARRL Extra Manual: Page 9-37

Ham Academy Lesson: 7D

Extra Class Questions valid thru 06-30-2016  
Emergency Amateur Radio Club - [www.earchi.org/education](http://www.earchi.org/education)

E9G11

**How are the wavelength scales on a Smith chart calibrated?**

- A. In fractions of transmission line electrical frequency
- B. In fractions of transmission line electrical wavelength
- C. In fractions of antenna electrical wavelength
- D. In fractions of antenna electrical frequency

E9G11

**B. In fractions of transmission line electrical wavelength**

ARRL Extra Manual: Page 9-37

Ham Academy Lesson: 7D

Extra Class Questions valid thru 06-30-2016  
Emergency Amateur Radio Club - [www.earchi.org/education](http://www.earchi.org/education)

E9F10

**What impedance does a 1/8-wavelength transmission line present to a generator when the line is shorted at the far end?**

- A. A capacitive reactance
- B. The same as the characteristic impedance of the line
- C. An inductive reactance
- D. The same as the input impedance to the final generator stage

E9F10

**C. An inductive reactance**

ARRL Extra Manual: Page 9-39

Ham Academy Lesson: 7D

Extra Class Questions valid thru 06-30-2016  
Emergency Amateur Radio Club - [www.earchi.org/education](http://www.earchi.org/education)

E9F11

**What impedance does a 1/8-wavelength transmission line present to a generator when the line is open at the far end?**

- A. The same as the characteristic impedance of the line
- B. An inductive reactance
- C. A capacitive reactance
- D. The same as the input impedance of the final generator stage

E9F11

**C. A capacitive reactance**

ARRL Extra Manual: Page 9-39

Ham Academy Lesson: 7D

Extra Class Questions valid thru 06-30-2016  
Emergency Amateur Radio Club - [www.earchi.org/education](http://www.earchi.org/education)



E9F12

**What impedance does a 1/4-wavelength transmission line present to a generator when the line is open at the far end?**

- A. The same as the characteristic impedance of the line
- B. The same as the input impedance to the generator
- C. Very high impedance
- D. Very low impedance

E9F12

**D. Very low impedance**

ARRL Extra Manual: Page 9-39

Ham Academy Lesson: 7D

Extra Class Questions valid thru 06-30-2016  
Emergency Amateur Radio Club - [www.earchi.org/education](http://www.earchi.org/education)

E9F13

**What impedance does a 1/4-wavelength transmission line present to a generator when the line is shorted at the far end?**

- A. Very high impedance
- B. Very low impedance
- C. The same as the characteristic impedance of the transmission line
- D. The same as the generator output impedance

E9F13

**A. Very high impedance**

ARRL Extra Manual: Page 9-39

Ham Academy Lesson: 7D

Extra Class Questions valid thru 06-30-2016  
Emergency Amateur Radio Club - [www.earchi.org/education](http://www.earchi.org/education)

E9F14

**What impedance does a 1/2-wavelength transmission line present to a generator when the line is shorted at the far end?**

- A. Very high impedance
- B. Very low impedance
- C. The same as the characteristic impedance of the line
- D. The same as the output impedance of the generator

E9F14

**B. Very low impedance**

ARRL Extra Manual: Page 9-39

Ham Academy Lesson: 7D

Extra Class Questions valid thru 06-30-2016  
Emergency Amateur Radio Club - [www.earchi.org/education](http://www.earchi.org/education)

E9F15

**What impedance does a 1/2-wavelength transmission line present to a generator when the line is open at the far end?**

- A. Very high impedance
- B. Very low impedance
- C. The same as the characteristic impedance of the line
- D. The same as the output impedance of the generator

E9F15

**A. Very high impedance**

ARRL Extra Manual: Page 9-39

Ham Academy Lesson: 7D

Extra Class Questions valid thru 06-30-2016  
Emergency Amateur Radio Club - [www.earchi.org/education](http://www.earchi.org/education)

E4A07

**Which of the following is an advantage of using an antenna analyzer compared to an SWR bridge to measure antenna SWR?**

- A. Antenna analyzers automatically tune your antenna for resonance
- B. Antenna analyzers do not need an external RF source
- C. Antenna analyzers display a time-varying representation of the modulation envelope
- D. All of these choices are correct

E4A07

**B. Antenna analyzers do not need an external RF source**

ARRL Extra Manual: Page 9-40

Ham Academy Lesson: 7D

Extra Class Questions valid thru 06-30-2016  
Emergency Amateur Radio Club - [www.earchi.org/education](http://www.earchi.org/education)

E4A08

**Which of the following instruments would be best for measuring the SWR of a beam antenna?**

- A. A spectrum analyzer
- B. A Q meter
- C. An ohmmeter
- D. An antenna analyzer

E4A08

**D. An antenna analyzer**

ARRL Extra Manual: Page 9-40

Ham Academy Lesson: 7D

Extra Class Questions valid thru 06-30-2016  
Emergency Amateur Radio Club - [www.earchi.org/education](http://www.earchi.org/education)

E4B11

**How should a portable antenna analyzer be connected when measuring antenna resonance and feed point impedance?**

- A. Loosely couple the analyzer near the antenna base
- B. Connect the analyzer via a high-impedance transformer to the antenna
- C. Connect the antenna and a dummy load to the analyzer
- D. Connect the antenna feed line directly to the analyzer's connector

E4B11

**D. Connect the antenna feed line directly to the analyzer's connector**

ARRL Extra Manual: Page 9-40

Ham Academy Lesson: 7D

Extra Class Questions valid thru 06-30-2016  
Emergency Amateur Radio Club - [www.earchi.org/education](http://www.earchi.org/education)

E9E10

**Which of these choices is an effective way to match an antenna with a 100-ohm feed point impedance to a 50-ohm coaxial cable feed line?**

- A. Connect a 1/4-wavelength open stub of 300-ohm twin-lead in parallel with the coaxial feed line where it connects to the antenna
- B. Insert a 1/2 wavelength piece of 300-ohm twin-lead in series between the antenna terminals and the 50-ohm feed cable
- C. Insert a 1/4-wavelength piece of 75-ohm coaxial cable transmission line in series between the antenna terminals and the 50-ohm feed cable
- D. Connect 1/2 wavelength shorted stub of 75-ohm cable in parallel with the 50-ohm cable where it attaches to the antenna

E9E10

**C. Insert a 1/4-wavelength piece of 75-ohm coaxial cable transmission line in series between the antenna terminals and the 50-ohm feed cable**

ARRL Extra Manual: Page 9-40

Ham Academy Lesson: 7D

Extra Class Questions valid thru 06-30-2016  
Emergency Amateur Radio Club - [www.earchi.org/education](http://www.earchi.org/education)

E9B09

**What type of computer program technique is commonly used for modeling antennas?**

- A. Graphical analysis
- B. Method of Moments
- C. Mutual impedance analysis
- D. Calculus differentiation with respect to physical properties

E9B09

**B. Method of Moments**

ARRL Extra Manual: Page 9-41

Ham Academy Lesson: 7D

Extra Class Questions valid thru 06-30-2016  
Emergency Amateur Radio Club - [www.earchi.org/education](http://www.earchi.org/education)

E9B10

**What is the principle of a Method of Moments analysis?**

- A. A wire is modeled as a series of segments, each having a uniform value of current
- B. A wire is modeled as a single sine-wave current generator
- C. A wire is modeled as a series of points, each having a distinct location in space
- D. A wire is modeled as a series of segments, each having a distinct value of voltage across it

E9B10

**A. A wire is modeled as a series of segments, each having a uniform value of current**

ARRL Extra Manual: Page 9-41

Ham Academy Lesson: 7D

Extra Class Questions valid thru 06-30-2016  
Emergency Amateur Radio Club - [www.earchi.org/education](http://www.earchi.org/education)

E9B13

**What does the abbreviation NEC stand for when applied to antenna modeling programs?**

- A. Next Element Comparison
- B. Numerical Electromagnetics Code
- C. National Electrical Code
- D. Numeric Electrical Computation

E9B13

**B. Numerical Electromagnetics Code**

ARRL Extra Manual: Page 9-41

Ham Academy Lesson: 7D

Extra Class Questions valid thru 06-30-2016  
Emergency Amateur Radio Club - [www.earchi.org/education](http://www.earchi.org/education)

E9B04

**What may occur when a directional antenna is operated at different frequencies within the band for which it was designed?**

- A. Feed point impedance may become negative
- B. The E-field and H-field patterns may reverse
- C. Element spacing limits could be exceeded
- D. The gain may change depending on frequency

E9B04

**D. The gain may change depending on frequency**

ARRL Extra Manual: Page 9-42

Ham Academy Lesson: 7D

Extra Class Questions valid thru 06-30-2016  
Emergency Amateur Radio Club - [www.earchi.org/education](http://www.earchi.org/education)

E9B05

**What usually occurs if a Yagi antenna is designed solely for maximum forward gain?**

- A. The front-to-back ratio increases
- B. The front-to-back ratio decreases
- C. The frequency response is widened over the whole frequency band
- D. The SWR is reduced

E9B05

**B. The front-to-back ratio decreases**

ARRL Extra Manual: Page 9-42

Ham Academy Lesson: 7D

Extra Class Questions valid thru 06-30-2016  
Emergency Amateur Radio Club - [www.earchi.org/education](http://www.earchi.org/education)

E9B06

**If the boom of a Yagi antenna is lengthened and the elements are properly retuned, what usually occurs?**

- A. The gain increases
- B. The SWR decreases
- C. The front-to-back ratio increases
- D. The gain bandwidth decreases rapidly

E9B06

**A. The gain increases**

ARRL Extra Manual: Page 9-42

Ham Academy Lesson: 7D

Extra Class Questions valid thru 06-30-2016  
Emergency Amateur Radio Club - [www.earchi.org/education](http://www.earchi.org/education)

E9B11

**What is a disadvantage of decreasing the number of wire segments in an antenna model below the guideline of 10 segments per half-wavelength?**

- A. Ground conductivity will not be accurately modeled
- B. The resulting design will favor radiation of harmonic energy
- C. The computed feed point impedance may be incorrect
- D. The antenna will become mechanically unstable

E9B11

**C. The computed feed point impedance may be incorrect**

ARRL Extra Manual: Page 9-42

Ham Academy Lesson: 7D

Extra Class Questions valid thru 06-30-2016  
Emergency Amateur Radio Club - [www.earchi.org/education](http://www.earchi.org/education)

E9B14

**What type of information can be obtained by submitting the details of a proposed new antenna to a modeling program?**

- A. SWR vs. frequency charts
- B. Polar plots of the far-field elevation and azimuth patterns
- C. Antenna gain
- D. All of these choices are correct

E9B14

**D. All of these choices are correct**

ARRL Extra Manual: Page 9-42

Ham Academy Lesson: 7D

Extra Class Questions valid thru 06-30-2016  
Emergency Amateur Radio Club - [www.earchi.org/education](http://www.earchi.org/education)

E3C08

**What is the name of the high-angle wave in HF propagation that travels for some distance within the F2 region?**

- A. Oblique-angle ray
- B. Pedersen ray
- C. Ordinary ray
- D. Heaviside ray

E3C08

**B. Pedersen ray**

ARRL Extra Manual: Page 10-2

Ham Academy Lesson: 8A

Extra Class Questions valid thru 06-30-2016  
Emergency Amateur Radio Club - [www.earchi.org/education](http://www.earchi.org/education)

E3C12

**How does the maximum distance of ground-wave propagation change when the signal frequency is increased?**

- A. It stays the same
- B. It increases
- C. It decreases
- D. It peaks at roughly 14 MHz

E3C12

**C. It decreases**

ARRL Extra Manual: Page 10-2

Ham Academy Lesson: 8A

Extra Class Questions valid thru 06-30-2016  
Emergency Amateur Radio Club - [www.earchi.org/education](http://www.earchi.org/education)

E3C13

**What type of polarization is best for ground-wave propagation?**

- A. Vertical
- B. Horizontal
- C. Circular
- D. Elliptical

E3C13

**A. Vertical**

ARRL Extra Manual: Page 10-2

Ham Academy Lesson: 8A

Extra Class Questions valid thru 06-30-2016  
Emergency Amateur Radio Club - [www.earchi.org/education](http://www.earchi.org/education)

E3B04

**What type of propagation is probably occurring if an HF beam antenna must be pointed in a direction 180 degrees away from a station to receive the strongest signals?**

- A. Long-path
- B. Sporadic-E
- C. Transequatorial
- D. Auroral

E3B04

**A. Long-path**

ARRL Extra Manual: Page 10-4

Ham Academy Lesson: 8A

Extra Class Questions valid thru 06-30-2016  
Emergency Amateur Radio Club - [www.earchi.org/education](http://www.earchi.org/education)

E3B05

**Which amateur bands typically support long-path propagation?**

- A. 160 to 40 meters
- B. 30 to 10 meters
- C. 160 to 10 meters
- D. 6 meters to 2 meters

E3B05

**C. 160 to 10 meters**

ARRL Extra Manual: Page 10-4

Ham Academy Lesson: 8A

Extra Class Questions valid thru 06-30-2016  
Emergency Amateur Radio Club - [www.earchi.org/education](http://www.earchi.org/education)

E3B06

**Which of the following amateur bands most frequently provides long-path propagation?**

- A. 80 meters
- B. 20 meters
- C. 10 meters
- D. 6 meters

E3B06

**B. 20 meters**

ARRL Extra Manual: Page 10-4

Ham Academy Lesson: 8A

Extra Class Questions valid thru 06-30-2016  
Emergency Amateur Radio Club - [www.earchi.org/education](http://www.earchi.org/education)

E3B07

**Which of the following could account for hearing an echo on the received signal of a distant station?**

- A. High D layer absorption
- B. Meteor scatter
- C. Transmit frequency is higher than the MUF
- D. Receipt of a signal by more than one path

E3B07

**D. Receipt of a signal by more than one path**

ARRL Extra Manual: Page 10-4

Ham Academy Lesson: 8A

Extra Class Questions valid thru 06-30-2016  
Emergency Amateur Radio Club - [www.earchi.org/education](http://www.earchi.org/education)

E3B08

**What type of HF propagation is probably occurring if radio signals travel along the terminator between daylight and darkness?**

- A. Transequatorial
- B. Sporadic-E
- C. Long-path
- D. Gray-line

E3B08

**D. Gray-line**

ARRL Extra Manual: Page 10-4

Ham Academy Lesson: 8A

Extra Class Questions valid thru 06-30-2016  
Emergency Amateur Radio Club - [www.earchi.org/education](http://www.earchi.org/education)

E3B09

**At what time of day is gray-line propagation most likely to occur?**

- A. At sunrise and sunset
- B. When the Sun is directly above the location of the transmitting station
- C. When the Sun is directly overhead at the middle of the communications path between the two stations
- D. When the Sun is directly above the location of the receiving station

E3B09

**A. At sunrise and sunset**

ARRL Extra Manual: Page 10-4

Ham Academy Lesson: 8A

Extra Class Questions valid thru 06-30-2016  
Emergency Amateur Radio Club - [www.earchi.org/education](http://www.earchi.org/education)

E3B10

**What is the cause of gray-line propagation?**

- A. At midday, the Sun being directly overhead superheats the ionosphere causing increased refraction of radio waves
- B. At twilight, D-layer absorption drops while E-layer and F-layer propagation remain strong
- C. In darkness, solar absorption drops greatly while atmospheric ionization remains steady
- D. At mid afternoon, the Sun heats the ionosphere decreasing radio wave refraction and the MUF

E3B10

**B. At twilight, D-layer absorption drops while E-layer and F-layer propagation remain strong**

ARRL Extra Manual: Page 10-4

Ham Academy Lesson: 8A

Extra Class Questions valid thru 06-30-2016  
Emergency Amateur Radio Club - [www.earchi.org/education](http://www.earchi.org/education)

E3B11

**Which of the following describes gray-line propagation?**

- A. Backscatter contacts on the 10 meter band
- B. Over the horizon propagation on the 6 and 2 meter bands
- C. Long distance communications at twilight on frequencies less than 15 MHz
- D. Tropospheric propagation on the 2 meter and 70 centimeter bands

E3B11

**C. Long distance communications at twilight on frequencies less than 15 MHz**

ARRL Extra Manual: Page 10-4

Ham Academy Lesson: 8A

Extra Class Questions valid thru 06-30-2016  
Emergency Amateur Radio Club - [www.earchi.org/education](http://www.earchi.org/education)

E3C05

**Which of the following describes selective fading?**

- A. Variability of signal strength with beam heading
- B. Partial cancellation of some frequencies within the received pass band
- C. Sideband inversion within the ionosphere
- D. Degradation of signal strength due to backscatter

E3C05

**B. Partial cancellation of some frequencies within the received pass band**

ARRL Extra Manual: Page 10-5

Ham Academy Lesson: 8A

Extra Class Questions valid thru 06-30-2016  
Emergency Amateur Radio Club - [www.earchi.org/education](http://www.earchi.org/education)

E3C06

**By how much does the VHF/UHF radio-path horizon distance exceed the geometric horizon?**

- A. By approximately 15% of the distance
- B. By approximately twice the distance
- C. By approximately one-half the distance
- D. By approximately four times the distance

E3C06

**A. By approximately 15% of the distance**

ARRL Extra Manual: Page 10-7

Ham Academy Lesson: 8A

Extra Class Questions valid thru 06-30-2016  
Emergency Amateur Radio Club - [www.earchi.org/education](http://www.earchi.org/education)

E3C14

**Why does the radio-path horizon distance exceed the geometric horizon?**

- A. E-region skip
- B. D-region skip
- C. Downward bending due to aurora refraction
- D. Downward bending due to density variations in the atmosphere

E3C14

**D. Downward bending due to density variations in the atmosphere**

ARRL Extra Manual: Page 10-7

Ham Academy Lesson: 8A

Extra Class Questions valid thru 06-30-2016  
Emergency Amateur Radio Club - [www.earchi.org/education](http://www.earchi.org/education)

E3B01

**What is transequatorial propagation?**

- A. Propagation between two mid-latitude points at approximately the same distance north and south of the magnetic equator
- B. Propagation between any two points located on the magnetic equator
- C. Propagation between two continents by way of ducts along the magnetic equator
- D. Propagation between two stations at the same latitude

E3B01

**A. Propagation between two mid-latitude points at approximately the same distance north and south of the magnetic equator**

ARRL Extra Manual: Page 10-8

Ham Academy Lesson: 8A

Extra Class Questions valid thru 06-30-2016  
Emergency Amateur Radio Club - [www.earchi.org/education](http://www.earchi.org/education)

E3C09

**Which of the following is usually responsible for causing VHF signals to propagate for hundreds of miles?**

- A. D-region absorption
- B. Faraday rotation
- C. Tropospheric ducting
- D. Ground wave

E3C09

**C. Tropospheric ducting**

ARRL Extra Manual: Page 10-8

Ham Academy Lesson: 8A

Extra Class Questions valid thru 06-30-2016  
Emergency Amateur Radio Club - [www.earchi.org/education](http://www.earchi.org/education)



E3B02

**What is the approximate maximum range for signals using transequatorial propagation?**

- A. 1000 miles
- B. 2500 miles
- C. 5000 miles
- D. 7500 miles

E3B02

**C. 5000 miles**

ARRL Extra Manual: Page 10-9

Ham Academy Lesson: 8A

Extra Class Questions valid thru 06-30-2016  
Emergency Amateur Radio Club - [www.earchi.org/education](http://www.earchi.org/education)

E3B03

**What is the best time of day for transequatorial propagation?**

- A. Morning
- B. Noon
- C. Afternoon or early evening
- D. Late at night

E3B03

**C. Afternoon or early evening**

ARRL Extra Manual: Page 10-9

Ham Academy Lesson: 8A

Extra Class Questions valid thru 06-30-2016  
Emergency Amateur Radio Club - [www.earchi.org/education](http://www.earchi.org/education)

E3C02

**What is the cause of Aurora activity?**

- A. The interaction between the solar wind and the Van Allen belt
- B. A low sunspot level combined with tropospheric ducting
- C. The interaction of charged particles from the Sun with the Earth's magnetic field and the ionosphere
- D. Meteor showers concentrated in the northern latitudes

E3C02

**C. The interaction of charged particles from the Sun with the Earth's magnetic field and the ionosphere**

ARRL Extra Manual: Page 10-9

Ham Academy Lesson: 8B

Extra Class Questions valid thru 06-30-2016  
Emergency Amateur Radio Club - [www.earchi.org/education](http://www.earchi.org/education)

E3C03

**Where in the ionosphere does Aurora activity occur?**

- A. In the F1-region
- B. In the F2-region
- C. In the D-region
- D. In the E-region

E3C03

**D. In the E-region**

ARRL Extra Manual: Page 10-9

Ham Academy Lesson: 8B

Extra Class Questions valid thru 06-30-2016  
Emergency Amateur Radio Club - [www.earchi.org/education](http://www.earchi.org/education)

E3C01

**Which of the following effects does Aurora activity have on radio communications?**

- A. SSB signals are raspy
- B. Signals propagating through the Aurora are fluttery
- C. CW signals appear to be modulated by white noise
- D. All of these choices are correct

E3C01

**D. All of these choices are correct**

ARRL Extra Manual: Page 10-10

Ham Academy Lesson: 8B

Extra Class Questions valid thru 06-30-2016  
Emergency Amateur Radio Club - [www.earchi.org/education](http://www.earchi.org/education)

E3C04

**Which emission mode is best for Aurora propagation?**

- A. CW
- B. SSB
- C. FM
- D. RTTY

E3C04

**A. CW**

ARRL Extra Manual: Page 10-10

Ham Academy Lesson: 8B

Extra Class Questions valid thru 06-30-2016  
Emergency Amateur Radio Club - [www.earchi.org/education](http://www.earchi.org/education)

E3C11

**From the contiguous 48 states, in which approximate direction should an antenna be pointed to take maximum advantage of aurora propagation?**

- A. South
- B. North
- C. East
- D. West

E3C11

**B. North**

ARRL Extra Manual: Page 10-10

Ham Academy Lesson: 8B

Extra Class Questions valid thru 06-30-2016  
Emergency Amateur Radio Club - [www.earchi.org/education](http://www.earchi.org/education)

E3A08

**When a meteor strikes the Earth's atmosphere, a cylindrical region of free electrons is formed at what layer of the ionosphere?**

- A. The E layer
- B. The F1 layer
- C. The F2 layer
- D. The D layer

E3A08

**A. The E layer**

ARRL Extra Manual: Page 10-11

Ham Academy Lesson: 8B

Extra Class Questions valid thru 06-30-2016  
Emergency Amateur Radio Club - [www.earchi.org/education](http://www.earchi.org/education)

E3A09

**Which of the following frequency ranges is well suited for meteor-scatter communications?**

- A. 1.8 - 1.9 MHz
- B. 10 - 14 MHz
- C. 28 - 148 MHz
- D. 220 - 450 MHz

E3A09

**C. 28 - 148 MHz**

ARRL Extra Manual: Page 10-11

Ham Academy Lesson: 8B

Extra Class Questions valid thru 06-30-2016  
Emergency Amateur Radio Club - [www.earchi.org/education](http://www.earchi.org/education)

E3A10

**Which of the following is a good technique for making meteor-scatter contacts?**

- A. 15 second timed transmission sequences with stations alternating based on location
- B. Use of high speed CW or digital modes
- C. Short transmission with rapidly repeated call signs and signal reports
- D. All of these choices are correct

E3A10

**D. All of these choices are correct**

ARRL Extra Manual: Page 10-12

Ham Academy Lesson: 8B

Extra Class Questions valid thru 06-30-2016  
Emergency Amateur Radio Club - [www.earchi.org/education](http://www.earchi.org/education)

E3A01

**What is the approximate maximum separation measured along the surface of the Earth between two stations communicating by Moon bounce?**

- A. 500 miles, if the Moon is at perigee
- B. 2000 miles, if the Moon is at apogee
- C. 5000 miles, if the Moon is at perigee
- D. 12,000 miles, as long as both can "see" the Moon

E3A01

**D. 12,000 miles, as long as both can "see" the Moon**

ARRL Extra Manual: Page 10-13

Ham Academy Lesson: 8B

Extra Class Questions valid thru 06-30-2016  
Emergency Amateur Radio Club - [www.earchi.org/education](http://www.earchi.org/education)

E3A02

**What characterizes libration fading of an Earth-Moon-Earth signal?**

- A. A slow change in the pitch of the CW signal
- B. A fluttery irregular fading
- C. A gradual loss of signal as the Sun rises
- D. The returning echo is several Hertz lower in frequency than the transmitted signal

E3A02

**B. A fluttery irregular fading**

ARRL Extra Manual: Page 10-13

Ham Academy Lesson: 8B

Extra Class Questions valid thru 06-30-2016  
Emergency Amateur Radio Club - [www.earchi.org/education](http://www.earchi.org/education)

E3A03

**When scheduling EME contacts, which of these conditions will generally result in the least path loss?**

- A. When the Moon is at perigee
- B. When the Moon is full
- C. When the Moon is at apogee
- D. When the MUF is above 30 MHz

E3A03

**A. When the Moon is at perigee**

ARRL Extra Manual: Page 10-13

Ham Academy Lesson: 8B

Extra Class Questions valid thru 06-30-2016  
Emergency Amateur Radio Club - [www.earchi.org/education](http://www.earchi.org/education)

E3A04

**What type of receiving system is desirable for EME communications?**

- A. Equipment with very wide bandwidth
- B. Equipment with very low dynamic range
- C. Equipment with very low gain
- D. Equipment with very low noise figures

E3A04

**D. Equipment with very low noise figures**

ARRL Extra Manual: Page 10-13

Ham Academy Lesson: 8B

Extra Class Questions valid thru 06-30-2016  
Emergency Amateur Radio Club - [www.earchi.org/education](http://www.earchi.org/education)

E3A05

**Which of the following describes a method of establishing EME contacts?**

- A. Time synchronous transmissions with each station alternating
- B. Storing and forwarding digital messages
- C. Judging optimum transmission times by monitoring beacons from the Moon
- D. High speed CW identification to avoid fading

E3A05

**A. Time synchronous transmissions with each station alternating**

ARRL Extra Manual: Page 10-14

Ham Academy Lesson: 8B

Extra Class Questions valid thru 06-30-2016  
Emergency Amateur Radio Club - [www.earchi.org/education](http://www.earchi.org/education)

E3A06

**What frequency range would you normally tune to find EME signals in the 2 meter band?**

- A. 144.000 - 144.001 MHz
- B. 144.000 - 144.100 MHz
- C. 144.100 - 144.300 MHz
- D. 145.000 - 145.100 MHz

E3A06

**B. 144.000 - 144.100 MHz**

ARRL Extra Manual: Page 10-14

Ham Academy Lesson: 8B

Extra Class Questions valid thru 06-30-2016  
Emergency Amateur Radio Club - [www.earchi.org/education](http://www.earchi.org/education)

E3A07

**What frequency range would you normally tune to find EME signals in the 70 cm band?**

- A. 430.000 - 430.150 MHz
- B. 430.100 - 431.100 MHz
- C. 431.100 - 431.200 MHz
- D. 432.000 - 432.100 MHz

E3A07

**D. 432.000 - 432.100 MHz**

ARRL Extra Manual: Page 10-14

Ham Academy Lesson: 8B

Extra Class Questions valid thru 06-30-2016  
Emergency Amateur Radio Club - [www.earchi.org/education](http://www.earchi.org/education)

E0A10

**What material found in some electronic components such as high-voltage capacitors and transformers is considered toxic?**

- A. Polychlorinated biphenyls
- B. Polyethylene
- C. Polytetrafluoroethylene
- D. Polymorphic silicon

E0A10

**A. Polychlorinated biphenyls**

ARRL Extra Manual: Page 11-1

Ham Academy Lesson: 8C

Extra Class Questions valid thru 06-30-2016  
Emergency Amateur Radio Club - [www.earchi.org/education](http://www.earchi.org/education)

E0A09

**Which insulating material commonly used as a thermal conductor for some types of electronic devices is extremely toxic if broken or crushed and the particles are accidentally inhaled?**

- A. Mica
- B. Zinc oxide
- C. Beryllium Oxide
- D. Uranium Hexafluoride

E0A09

**C. Beryllium Oxide**

ARRL Extra Manual: Page 11-2

Ham Academy Lesson: 8C

Extra Class Questions valid thru 06-30-2016  
Emergency Amateur Radio Club - [www.earchi.org/education](http://www.earchi.org/education)

E0A01

**What, if any, are the differences between the radiation produced by radioactive materials and the electromagnetic energy radiated by an antenna?**

- A. There is no significant difference between the two types of radiation
- B. Only radiation produced by radioactivity can injure human beings
- C. Radioactive materials emit ionizing radiation, while RF signals have less energy and can only cause heating
- D. Radiation from an antenna will damage unexposed photographic film but ordinary radioactive materials do not cause this problem

E0A01

**C. Radioactive materials emit ionizing radiation, while RF signals have less energy and can only cause heating**

ARRL Extra Manual: Page 11-3

Ham Academy Lesson: 8C

Extra Class Questions valid thru 06-30-2016  
Emergency Amateur Radio Club - [www.earchi.org/education](http://www.earchi.org/education)

E0A07

**How may dangerous levels of carbon monoxide from an emergency generator be detected?**

- A. By the odor
- B. Only with a carbon monoxide detector
- C. Any ordinary smoke detector can be used
- D. By the yellowish appearance of the gas

E0A07

**B. Only with a carbon monoxide detector**

ARRL Extra Manual: Page 11-3

Ham Academy Lesson: 8C

Extra Class Questions valid thru 06-30-2016  
Emergency Amateur Radio Club - [www.earchi.org/education](http://www.earchi.org/education)

E0A11

**Which of the following injuries can result from using high-power UHF or microwave transmitters?**

- A. Hearing loss caused by high voltage corona discharge
- B. Blood clotting from the intense magnetic field
- C. Localized heating of the body from RF exposure in excess of the MPE limits
- D. Ingestion of ozone gas from the cooling system

E0A11

**C. Localized heating of the body from RF exposure in excess of the MPE limits**

ARRL Extra Manual: Page 11-3

Ham Academy Lesson: 8C

Extra Class Questions valid thru 06-30-2016  
Emergency Amateur Radio Club - [www.earchi.org/education](http://www.earchi.org/education)

E0A06

**Why are there separate electric (E) and magnetic (H) field MPE limits?**

- A. The body reacts to electromagnetic radiation from both the E and H fields
- B. Ground reflections and scattering make the field impedance vary with location
- C. E field and H field radiation intensity peaks can occur at different locations
- D. All of these choices are correct

E0A06

**D. All of these choices are correct**

ARRL Extra Manual: Page 11-4

Ham Academy Lesson: 8C

Extra Class Questions valid thru 06-30-2016  
Emergency Amateur Radio Club - [www.earchi.org/education](http://www.earchi.org/education)

E0A08

**What does SAR measure?**

- A. Synthetic Aperture Ratio of the human body
- B. Signal Amplification Rating
- C. The rate at which RF energy is absorbed by the body
- D. The rate of RF energy reflected from stationary terrain

E0A08

**C. The rate at which RF energy is absorbed by the body**

ARRL Extra Manual: Page 11-4

Ham Academy Lesson: 8C

Extra Class Questions valid thru 06-30-2016  
Emergency Amateur Radio Club - [www.earchi.org/education](http://www.earchi.org/education)

E0A02

**When evaluating RF exposure levels from your station at a neighbor's home, what must you do?**

- A. Make sure signals from your station are less than the controlled MPE limits
- B. Make sure signals from your station are less than the uncontrolled MPE limits
- C. You need only evaluate exposure levels on your own property
- D. Advise your neighbors of the results of your tests

E0A02

**B. Make sure signals from your station are less than the uncontrolled MPE limits**

ARRL Extra Manual: Page 11-5

Ham Academy Lesson: 8C

Extra Class Questions valid thru 06-30-2016  
Emergency Amateur Radio Club - [www.earchi.org/education](http://www.earchi.org/education)

E0A03

**Which of the following would be a practical way to estimate whether the RF fields produced by an amateur radio station are within permissible MPE limits?**

- A. Use a calibrated antenna analyzer
- B. Use a hand calculator plus Smith-chart equations to calculate the fields
- C. Use an antenna modeling program to calculate field strength at accessible locations
- D. All of the choices are correct

E0A03

**C. Use an antenna modeling program to calculate field strength at accessible locations**

ARRL Extra Manual: Page 11-7

Ham Academy Lesson: 8C

Extra Class Questions valid thru 06-30-2016  
Emergency Amateur Radio Club - [www.earchi.org/education](http://www.earchi.org/education)

E0A04

**When evaluating a site with multiple transmitters operating at the same time, the operators and licensees of which transmitters are responsible for mitigating over-exposure situations?**

- A. Only the most powerful transmitter
- B. Only commercial transmitters
- C. Each transmitter that produces 5% or more of its MPE exposure limit at accessible locations
- D. Each transmitter operating with a duty-cycle greater than 50%

E0A04

**C. Each transmitter that produces 5% or more of its MPE exposure limit at accessible locations**

ARRL Extra Manual: Page 11-7

Ham Academy Lesson: 8C

Extra Class Questions valid thru 06-30-2016  
Emergency Amateur Radio Club - [www.earchi.org/education](http://www.earchi.org/education)

E0A05

**What is one of the potential hazards of using microwaves in the amateur radio bands?**

- A. Microwaves are ionizing radiation
- B. The high gain antennas commonly used can result in high exposure levels
- C. Microwaves often travel long distances by ionospheric reflection
- D. The extremely high frequency energy can damage the joints of antenna structures

E0A05

**B. The high gain antennas commonly used can result in high exposure levels**

ARRL Extra Manual: Page 11-8

Ham Academy Lesson: 8C

Extra Class Questions valid thru 06-30-2016  
Emergency Amateur Radio Club - [www.earchi.org/education](http://www.earchi.org/education)

Figure E5-2

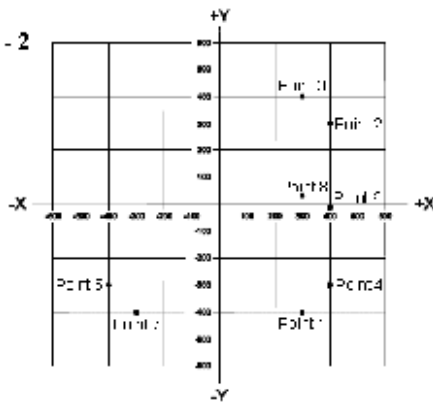

Figure E5-2

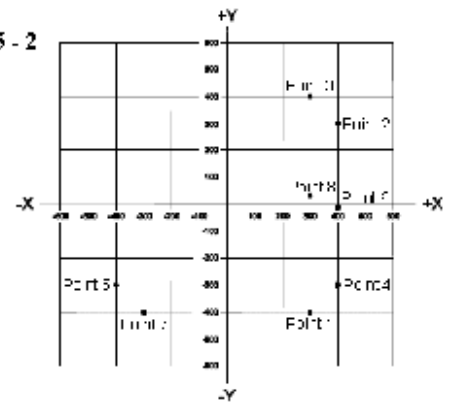

Figure E6-1

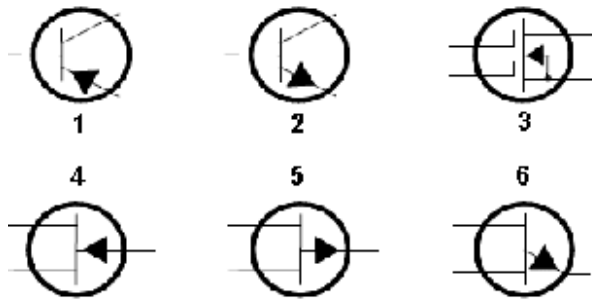

Figure E6-1

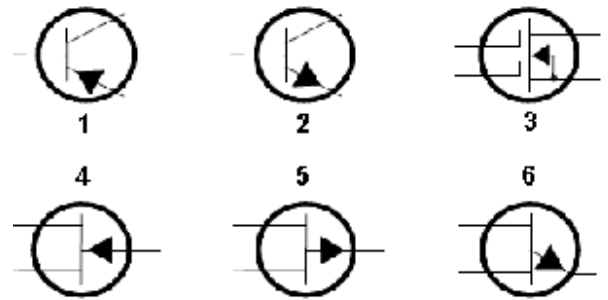

Figure E6-2

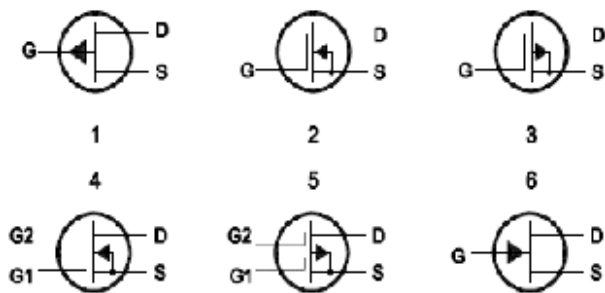

Figure E6-2

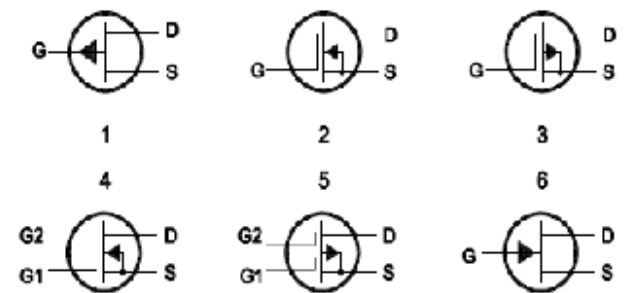

Figure E6-3

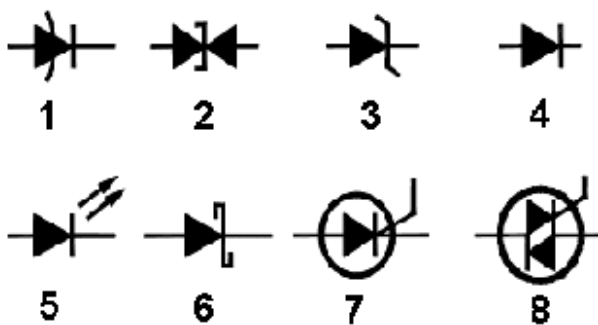

Figure E6-3

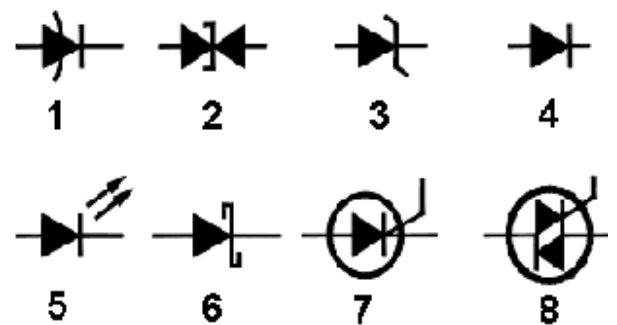



Figure E6-5

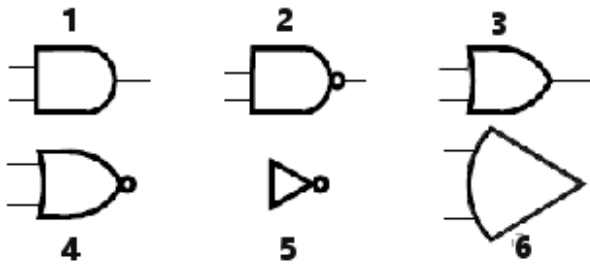

Figure E6-5

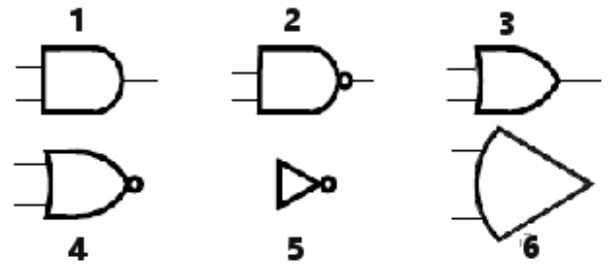

Figure E7-1

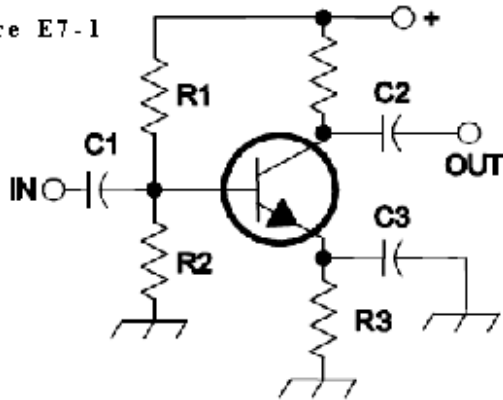

Figure E7-1

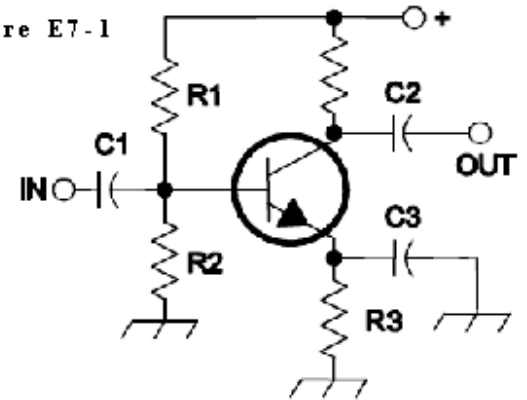

Figure E7-2

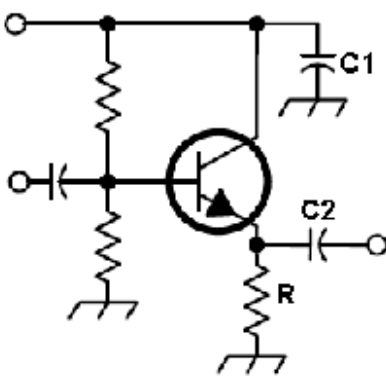

Figure E7-2

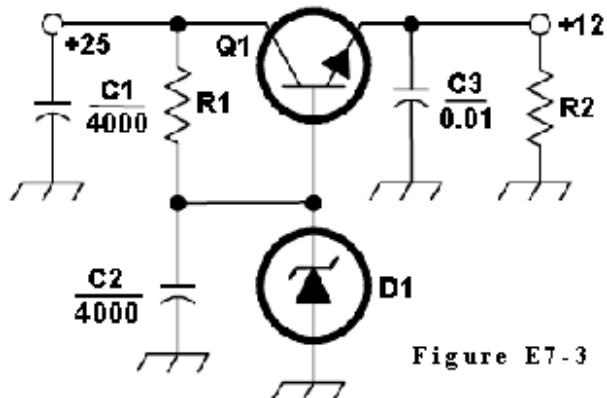
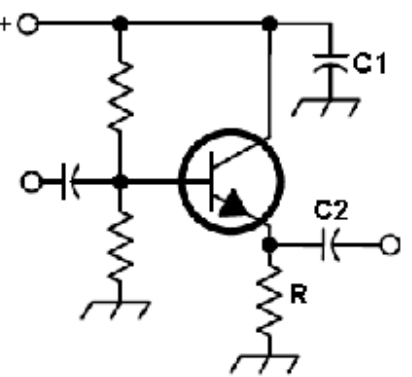

Figure E7-3

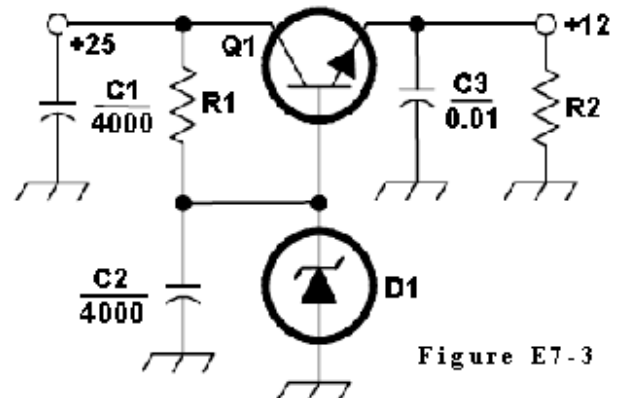

Figure E7-3

Figure E7-4

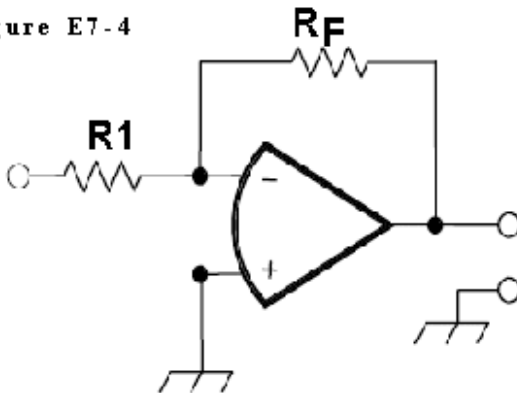

Figure E7-4

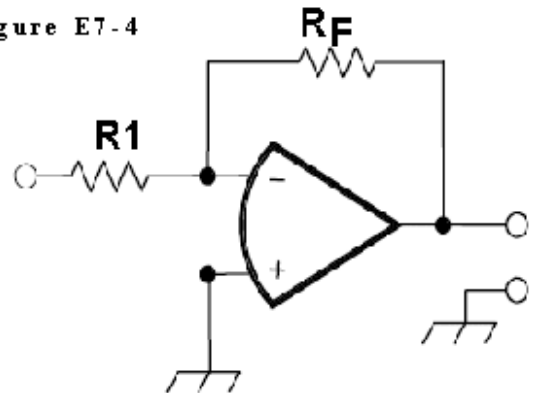

Figure E9-1

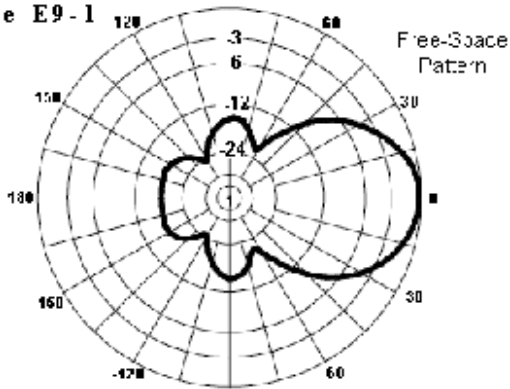

Figure E9-1

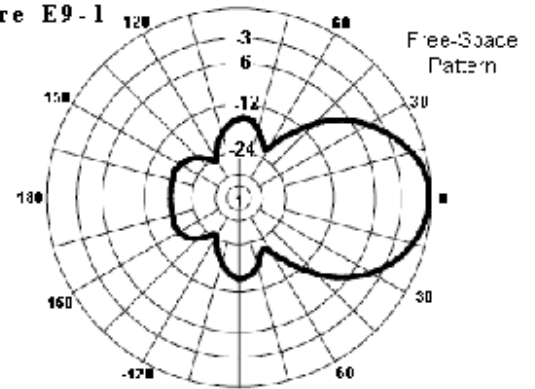

Figure E9-2

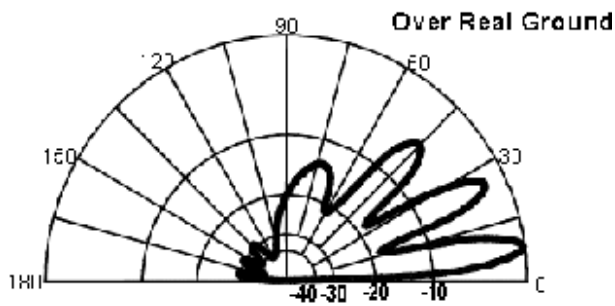

Figure E9-2

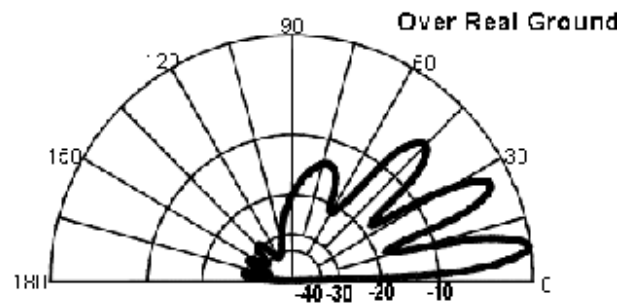

Figure E9-3

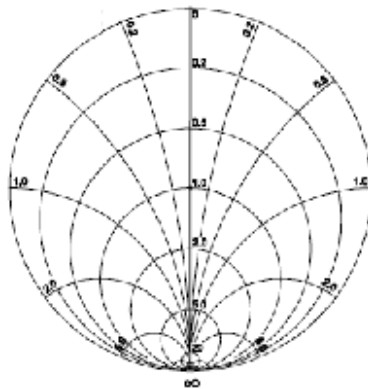

Figure E9-3

