

T5A12

What term describes the number of times per second that an alternating current reverses direction?

- A. Pulse rate
- B. Speed
- C. Wavelength
- D. Frequency

T5B01

How many milliamperes is 1.5 amperes?

- A. 15 milliamperes
- B. 150 milliamperes
- C. 1,500 milliamperes
- D. 15,000 milliamperes

T5B02

What is another way to specify a radio signal frequency of 1,500,000 hertz?

- A. 1500 kHz
- B. 1500 MHz
- C. 15 GHz
- D. 150 kHz

T5B03

How many volts are equal to one kilovolt?

- A. One one-thousandth of a volt
- B. One hundred volts
- C. One thousand volts
- D. One million volts

T5B04

How many volts are equal to one microvolt?

- A. One one-millionth of a volt
- B. One million volts
- C. One thousand kilovolts
- D. One one-thousandth of a volt

T5B05

Which of the following is equivalent to 500 milliwatts?

- A. 0.02 watts
- B. 0.5 watts
- C. 5 watts
- D. 50 watts

T5B06

If an ammeter calibrated in amperes is used to measure a 3000-milliamperere current, what reading would it show?

- A. 0.003 amperes
- B. 0.3 amperes
- C. 3 amperes
- D. 3,000,000 amperes

T5B07

If a frequency readout calibrated in megahertz shows a reading of 3.525 MHz, what would it show if it were calibrated in kilohertz?

- A. 0.003525 kHz
- B. 35.25 kHz
- C. 3525 kHz
- D. 3,525,000 kHz

T5B08

How many microfarads are 1,000,000 picofarads?

- A. 0.001 microfarads
- B. 1 microfarad
- C. 1000 microfarads
- D. 1,000,000,000 microfarads

T5B12

Which of the following frequencies is equal to 28,400 kHz?

- A. 28.400 MHz
- B. 2.800 MHz
- C. 284.00 MHz
- D. 28.400 kHz

T5B13

If a frequency readout shows a reading of 2425 MHz, what frequency is that in GHz?

- A. 0.002425 GHz
- B. 24.25 GHz
- C. 2.425 GHz
- D. 2425 GHz

T5C05

What is the unit of frequency?

- A. Hertz
- B. Henry
- C. Farad
- D. Tesla

T5C06

What does the abbreviation "RF" refer to?

- A. Radio frequency signals of all types
- B. The resonant frequency of a tuned circuit
- C. The real frequency transmitted as opposed to the apparent frequency
- D. Reflective force in antenna transmission lines

T3B08

What are the frequency limits of the VHF spectrum?

- A. 30 to 300 kHz
- B. 30 to 300 MHz
- C. 300 to 3000 kHz
- D. 300 to 3000 MHz

T3B09

What are the frequency limits of the UHF spectrum?

- A. 30 to 300 kHz
- B. 30 to 300 MHz
- C. 300 to 3000 kHz
- D. 300 to 3000 MHz

T3B10

What frequency range is referred to as HF?

- A. 300 to 3000 MHz
- B. 30 to 300 MHz
- C. 3 to 30 MHz
- D. 300 to 3000 kHz

T3B01

What is the name for the distance a radio wave travels during one complete cycle?

- A. Wave speed
- B. Waveform
- C. Wavelength
- D. Wave spread

T3B04

How fast does a radio wave travel through free space?

- A. At the speed of light
- B. At the speed of sound
- C. Its speed is inversely proportional to its wavelength
- D. Its speed increases as the frequency increases

T3B05

How does the wavelength of a radio wave relate to its frequency?

- A. The wavelength gets longer as the frequency increases
- B. The wavelength gets shorter as the frequency increases
- C. There is no relationship between wavelength and frequency
- D. The wavelength depends on the bandwidth of the signal

T3B07

What property of radio waves is often used to identify the different frequency bands?

- A. The approximate wavelength
- B. The magnetic intensity of waves
- C. The time it takes for waves to travel one mile
- D. The voltage standing wave ratio of waves

T3B11

What is the approximate velocity of a radio wave as it travels through free space?

- A. 3000 kilometers per second
- B. 300,000,000 meters per second
- C. 300,000 miles per hour
- D. 186,000 miles per hour

T3B06

What is the formula for converting frequency to approximate wavelength in meters?

- A. Wavelength in meters equals frequency in hertz multiplied by 300
- B. Wavelength in meters equals frequency in hertz divided by 300
- C. Wavelength in meters equals frequency in megahertz divided by 300
- D. Wavelength in meters equals 300 divided by frequency in megahertz

T2B06

What happens when the deviation of an FM transmitter is increased?

- A. Its signal occupies more bandwidth
- B. Its output power increases
- C. Its output power and bandwidth increases
- D. Asymmetric modulation occurs

T2B07

What could cause your FM signal to interfere with stations on nearby frequencies?

- A. Microphone gain too high, causing over-deviation
- B. SWR too high
- C. Incorrect CTCSS Tone
- D. All of these choices are correct

T8A01

Which of the following is a form of amplitude modulation?

- A. Spread-spectrum
- B. Packet radio
- C. Single sideband
- D. Phase shift keying

T1B09 [97.101(a), 97.301(a-e)]

Why should you not set your transmit frequency to be exactly at the edge of an amateur band or sub-band?

- A. To allow for calibration error in the transmitter frequency display
- B. So that modulation sidebands do not extend beyond the band edge
- C. To allow for transmitter frequency drift
- D. All of these choices are correct

T2B05

What determines the amount of deviation of an FM (as opposed to PM) signal?

- A. Both the frequency and amplitude of the modulating signal
- B. The frequency of the modulating signal
- C. The amplitude of the modulating signal
- D. The relative phase of the modulating signal and the carrier

T8A02

What type of modulation is most commonly used for VHF packet radio transmissions?

- A. FM
- B. SSB
- C. AM
- D. Spread Spectrum

T8A04

Which type of modulation is most commonly used for VHF and UHF voice repeaters?

- A. AM
- B. SSB
- C. PSK
- D. FM

T8A05

Which of the following types of emission has the narrowest bandwidth?

- A. FM voice
- B. SSB voice
- C. CW
- D. Slow-scan TV

T8A08

What is the approximate bandwidth of a single sideband voice signal?

- A. 1 kHz
- B. 3 kHz
- C. 6 kHz
- D. 15 kHz

T8A09

What is the approximate bandwidth of a VHF repeater FM phone signal?

- A. Less than 500 Hz
- B. About 150 kHz
- C. Between 10 and 15 kHz
- D. Between 50 and 125 kHz

T8A10

What is the typical bandwidth of analog fast-scan TV transmissions on the 70 cm band?

- A. More than 10 MHz
- B. About 6 MHz
- C. About 3 MHz
- D. About 1 MHz

T8A11

What is the approximate maximum bandwidth required to transmit a CW signal?

- A. 2.4 kHz
- B. 150 Hz
- C. 1000 Hz
- D. 15 kHz

T8A03

Which type of voice mode is most often used for long-distance (weak signal) contacts on the VHF and UHF bands?

- A. FM
- B. DRM
- C. SSB
- D. PM

T8A06

Which sideband is normally used for 10 meter HF, VHF and UHF single-sideband communications?

- A. Upper sideband
- B. Lower sideband
- C. Suppressed sideband
- D. Inverted sideband

T8A07

What is the primary advantage of single sideband over FM for voice transmissions?

- A. SSB signals are easier to tune
- B. SSB signals are less susceptible to interference
- C. SSB signals have narrower bandwidth
- D. All of these choices are correct

T1F09 [97.3(a)(40)]

What type of amateur station simultaneously retransmits the signal of another amateur station on a different channel or channels?

- A. Beacon station
- B. Earth station
- C. Repeater station
- D. Message forwarding station

T7A02

What is a transceiver?

- A. A type of antenna switch
- B. A unit combining the functions of a transmitter and a receiver
- C. A component in a repeater which filters out unwanted interference
- D. A type of antenna matching network

T5A01

Electrical current is measured in which of the following units?

- A. Volts
- B. Watts
- C. Ohms
- D. Amperes

T5A03

What is the name for the flow of electrons in an electric circuit?

- A. Voltage
- B. Resistance
- C. Capacitance
- D. Current

T5A05

What is the electrical term for the electromotive force (EMF) that causes electron flow?

- A. Voltage
- B. Ampere-hours
- C. Capacitance
- D. Inductance

T5A11

What is the basic unit of electromotive force?

- A. The volt
- B. The watt
- C. The ampere
- D. The ohm

T7D01

Which instrument would you use to measure electric potential or electromotive force?

- A. An ammeter
- B. A voltmeter
- C. A wavemeter
- D. An ohmmeter

T7D04

Which instrument is used to measure electric current?

- A. An ohmmeter
- B. A wavemeter
- C. A voltmeter
- D. An ammeter

T7D02

What is the correct way to connect a voltmeter to a circuit?

- A. In series with the circuit
- B. In parallel with the circuit
- C. In quadrature with the circuit
- D. In phase with the circuit

T7D03

How is an ammeter usually connected to a circuit?

- A. In series with the circuit
- B. In parallel with the circuit
- C. In quadrature with the circuit
- D. In phase with the circuit

T7D06

Which of the following might damage a multimeter?

- A. Measuring a voltage too small for the chosen scale
- B. Leaving the meter in the milliamps position overnight
- C. Attempting to measure voltage when using the resistance setting
- D. Not allowing it to warm up properly

T7D07

Which of the following measurements are commonly made using a multimeter?

- A. SWR and RF power
- B. Signal strength and noise
- C. Impedance and reactance
- D. Voltage and resistance

T7D10

What is probably happening when an ohmmeter, connected across an unpowered circuit, initially indicates a low resistance and then shows increasing resistance with time?

- A. The ohmmeter is defective
- B. The circuit contains a large capacitor
- C. The circuit contains a large inductor
- D. The circuit is a relaxation oscillator

T7D11

Which of the following precautions should be taken when measuring circuit resistance with an ohmmeter?

- A. Ensure that the applied voltages are correct
- B. Ensure that the circuit is not powered
- C. Ensure that the circuit is grounded
- D. Ensure that the circuit is operating at the correct frequency

T7D12

Which of the following precautions should be taken when measuring high voltages with a voltmeter?

- A. Ensure that the voltmeter has very low impedance
- B. Ensure that the voltmeter and leads are rated for use at the voltages to be measured
- C. Ensure that the circuit is grounded through the voltmeter
- D. Ensure that the voltmeter is set to the correct frequency

T5A07

Which of the following is a good electrical conductor?

- A. Glass
- B. Wood
- C. Copper
- D. Rubber

T5A08

Which of the following is a good electrical insulator?

- A. Copper
- B. Glass
- C. Aluminum
- D. Mercury

T5D01

What formula is used to calculate current in a circuit?

- A. Current (I) equals voltage (E) multiplied by resistance (R)
- B. Current (I) equals voltage (E) divided by resistance (R)
- C. Current (I) equals voltage (E) added to resistance (R)
- D. Current (I) equals voltage (E) minus resistance (R)

T5D02

What formula is used to calculate voltage in a circuit?

- A. Voltage (E) equals current (I) multiplied by resistance (R)
- B. Voltage (E) equals current (I) divided by resistance (R)
- C. Voltage (E) equals current (I) added to resistance (R)
- D. Voltage (E) equals current (I) minus resistance (R)

T5D03

What formula is used to calculate resistance in a circuit?

- A. Resistance (R) equals voltage (E) multiplied by current (I)
- B. Resistance (R) equals voltage (E) divided by current (I)
- C. Resistance (R) equals voltage (E) added to current (I)
- D. Resistance (R) equals voltage (E) minus current (I)

T7D05

What instrument is used to measure resistance?

- A. An oscilloscope
- B. A spectrum analyzer
- C. A noise bridge
- D. An ohmmeter

T5D04

What is the resistance of a circuit in which a current of 3 amperes flows through a resistor connected to 90 volts?

- A. 3 ohms
- B. 30 ohms
- C. 93 ohms
- D. 270 ohms

T5D05

What is the resistance in a circuit for which the applied voltage is 12 volts and the current flow is 1.5 amperes?

- A. 18 ohms
- B. 0.125 ohms
- C. 8 ohms
- D. 13.5 ohms

T5D06

What is the resistance of a circuit that draws 4 amperes from a 12-volt source?

- A. 3 ohms
- B. 16 ohms
- C. 48 ohms
- D. 8 Ohms

T5D07

What is the current flow in a circuit with an applied voltage of 120 volts and a resistance of 80 ohms?

- A. 9600 amperes
- B. 200 amperes
- C. 0.667 amperes
- D. 1.5 amperes

T5D08

What is the current flowing through a 100-ohm resistor connected across 200 volts?

- A. 20,000 amperes
- B. 0.5 amperes
- C. 2 amperes
- D. 100 amperes

T5D09

What is the current flowing through a 24-ohm resistor connected across 240 volts?

- A. 24,000 amperes
- B. 0.1 amperes
- C. 10 amperes
- D. 216 amperes

T5D10

What is the voltage across a 2-ohm resistor if a current of 0.5 amperes flows through it?

- A. 1 volt
- B. 0.25 volts
- C. 2.5 volts
- D. 1.5 volts

T5D11

What is the voltage across a 10-ohm resistor if a current of 1 ampere flows through it?

- A. 1 volt
- B. 10 volts
- C. 11 volts
- D. 9 volts

T5D12

What is the voltage across a 10-ohm resistor if a current of 2 amperes flows through it?

- A. 8 volts
- B. 0.2 volts
- C. 12 volts
- D. 20 volts

T5A02

Electrical power is measured in which of the following units?

- A. Volts
- B. Watts
- C. Ohms
- D. Amperes

T5A10

Which term describes the rate at which electrical energy is used?

- A. Resistance
- B. Current
- C. Power
- D. Voltage

T5C08

What is the formula used to calculate electrical power in a DC circuit?

- A. Power (P) equals voltage (E) multiplied by current (I)
- B. Power (P) equals voltage (E) divided by current (I)
- C. Power (P) equals voltage (E) minus current (I)
- D. Power (P) equals voltage (E) plus current (I)

T5C09

How much power is being used in a circuit when the applied voltage is 13.8 volts DC and the current is 10 amperes?

- A. 138 watts
- B. 0.7 watts
- C. 23.8 watts
- D. 3.8 watts

T5C10

How much power is being used in a circuit when the applied voltage is 12 volts DC and the current is 2.5 amperes?

- A. 4.8 watts
- B. 30 watts
- C. 14.5 watts
- D. 0.208 watts

T5C11

How many amperes are flowing in a circuit when the applied voltage is 12 volts DC and the load is 120 watts?

- A. 0.1 amperes
- B. 10 amperes
- C. 12 amperes
- D. 132 amperes

T5A04

What is the name for a current that flows only in one direction?

- A. Alternating current
- B. Direct current
- C. Normal current
- D. Smooth current

T5A09

What is the name for a current that reverses direction on a regular basis?

- A. Alternating current
- B. Direct current
- C. Circular current
- D. Vertical current

T5C01

What is the ability to store energy in an electric field called?

- A. Inductance
- B. Resistance
- C. Tolerance
- D. Capacitance

T5C02

What is the basic unit of capacitance?

- A. The farad
- B. The ohm
- C. The volt
- D. The henry

T5C03

What is the ability to store energy in a magnetic field called?

- A. Admittance
- B. Capacitance
- C. Resistance
- D. Inductance

T5C04

What is the basic unit of inductance?

- A. The coulomb
- B. The farad
- C. The henry
- D. The ohm

T6A01

What electrical component is used to oppose the flow of current in a DC circuit?

- A. Inductor
- B. Resistor
- C. Voltmeter
- D. Transformer

T6A04

What electrical component stores energy in an electric field?

- A. Resistor
- B. Capacitor
- C. Inductor
- D. Diode

T6A05

What type of electrical component consists of two or more conductive surfaces separated by an insulator?

- A. Resistor
- B. Potentiometer
- C. Oscillator
- D. Capacitor

T6A06

What type of electrical component stores energy in a magnetic field?

- A. Resistor
- B. Capacitor
- C. Inductor
- D. Diode

T6A07

What electrical component is usually composed of a coil of wire?

- A. Switch
- B. Capacitor
- C. Diode
- D. Inductor

T5C12

What is meant by the term impedance?

- A. It is a measure of the opposition to AC current flow in a circuit
- B. It is the inverse of resistance
- C. It is a measure of the Q or Quality Factor of a component
- D. It is a measure of the power handling capability of a component

T5C13

What are the units of impedance?

- A. Volts
- B. Amperes
- C. Coulombs
- D. Ohms

T6A02

What type of component is often used as an adjustable volume control?

- A. Fixed resistor
- B. Power resistor
- C. Potentiometer
- D. Transformer

T6A03

What electrical parameter is controlled by a potentiometer?

- A. Inductance
- B. Resistance
- C. Capacitance
- D. Field strength

T6D06

What component is commonly used to change 120V AC house current to a lower AC voltage for other uses?

- A. Variable capacitor
- B. Transformer
- C. Transistor
- D. Diode

T6D08

Which of the following is used together with an inductor to make a tuned circuit?

- A. Resistor
- B. Zener diode
- C. Potentiometer
- D. Capacitor

T6D11

What is a simple resonant or tuned circuit?

- A. An inductor and a capacitor connected in series or parallel to form a filter
- B. A type of voltage regulator
- C. A resistor circuit used for reducing standing wave ratio
- D. A circuit designed to provide high fidelity audio

T6B02

What electronic component allows current to flow in only one direction?

- A. Resistor
- B. Fuse
- C. Diode
- D. Driven Element

T6B06

How is the cathode lead of a semiconductor diode usually identified?

- A. With the word cathode
- B. With a stripe
- C. With the letter C
- D. All of these choices are correct

T6B07

What does the abbreviation LED stand for?

- A. Low Emission Diode
- B. Light Emitting Diode
- C. Liquid Emission Detector
- D. Long Echo Delay

T6B09

What are the names of the two electrodes of a diode?

- A. Plus and minus
- B. Source and drain
- C. Anode and cathode
- D. Gate and base

T6D01

Which of the following devices or circuits changes an alternating current into a varying direct current signal?

- A. Transformer
- B. Rectifier
- C. Amplifier
- D. Reflector

T6B01

What class of electronic components is capable of using a voltage or current signal to control current flow?

- A. Capacitors
- B. Inductors
- C. Resistors
- D. Transistors

T6B03

Which of these components can be used as an electronic switch or amplifier?

- A. Oscillator
- B. Potentiometer
- C. Transistor
- D. Voltmeter

T6B04

Which of the following components can be made of three layers of semiconductor material?

- A. Alternator
- B. Transistor
- C. Triode
- D. Pentagrid converter

T6B05

Which of the following electronic components can amplify signals?

- A. Transistor
- B. Variable resistor
- C. Electrolytic capacitor
- D. Multi-cell battery

T6B08

What does the abbreviation FET stand for?

- A. Field Effect Transistor
- B. Fast Electron Transistor
- C. Free Electron Transition
- D. Field Emission Thickness

T6B10

What are the three electrodes of a PNP or NPN transistor?

- A. Emitter, base, and collector
- B. Source, gate, and drain
- C. Cathode, grid, and plate
- D. Cathode, drift cavity, and collector

T6B11

What are the three electrodes of a field effect transistor?

- A. Emitter, base, and collector
- B. Source, gate, and drain
- C. Cathode, grid, and plate
- D. Cathode, gate, and anode

T6B12

What is the term that describes a transistor's ability to amplify a signal?

- A. Gain
- B. Forward resistance
- C. Forward voltage drop
- D. On resistance

T6D07

Which of the following is commonly used as a visual indicator?

- A. LED
- B. FET
- C. Zener diode
- D. Bipolar transistor

T6D09

What is the name of a device that combines several semiconductors and other components into one package?

- A. Transducer
- B. Multi-pole relay
- C. Integrated circuit
- D. Transformer

T6D10

What is the function of component 2 in Figure T1?

- A. Give off light when current flows through it
- B. Supply electrical energy
- C. Control the flow of current
- D. Convert electrical energy into radio waves

T0A04

What is the purpose of a fuse in an electrical circuit?

- A. To prevent power supply ripple from damaging a circuit
- B. To interrupt power in case of overload
- C. To limit current to prevent shocks
- D. All of these choices are correct

T0A05

Why is it unwise to install a 20-ampere fuse in the place of a 5-ampere fuse?

- A. The larger fuse would be likely to blow because it is rated for higher current
- B. The power supply ripple would greatly increase
- C. Excessive current could cause a fire
- D. All of these choices are correct

T6A08

What electrical component is used to connect or disconnect electrical circuits?

- A. Magnetron
- B. Switch
- C. Thermistor
- D. All of these choices are correct

T6A09

What electrical component is used to protect other circuit components from current overloads?

- A. Fuse
- B. Capacitor
- C. Inductor
- D. All of these choices are correct

T6D02

What best describes a relay?

- A. A switch controlled by an electromagnet
- B. A current controlled amplifier
- C. An optical sensor
- D. A pass transistor

T6C01

What is the name for standardized representations of components in an electrical wiring diagram?

- A. Electrical depictions
- B. Grey sketch
- C. Schematic symbols
- D. Component callouts

T6C02

What is component 1 in Figure T1?

- A. Resistor
- B. Transistor
- C. Battery
- D. Connector

T6C03

What is component 2 in Figure T1?

- A. Resistor
- B. Transistor
- C. Indicator lamp
- D. Connector

T6C04

What is component 3 in Figure T1?

- A. Resistor
- B. Transistor
- C. Lamp
- D. Ground symbol

T6C05

What is component 4 in Figure T1?

- A. Resistor
- B. Transistor
- C. Battery
- D. Ground symbol

T6C06

What is component 6 in Figure T2?

- A. Resistor
- B. Capacitor
- C. Regulator IC
- D. Transistor

T6C07

What is component 8 in Figure T2?

- A. Resistor
- B. Inductor
- C. Regulator IC
- D. Light emitting diode

T6C08

What is component 9 in Figure T2?

- A. Variable capacitor
- B. Variable inductor
- C. Variable resistor
- D. Variable transformer

T6C09

What is component 4 in Figure T2?

- A. Variable inductor
- B. Double-pole switch
- C. Potentiometer
- D. Transformer

T6C10

What is component 3 in Figure T3?

- A. Connector
- B. Meter
- C. Variable capacitor
- D. Variable inductor

T6C11

What is component 4 in Figure T3?

- A. Antenna
- B. Transmitter
- C. Dummy load
- D. Ground

T6C12

What do the symbols on an electrical circuit schematic diagram represent?

- A. Electrical components
- B. Logic states
- C. Digital codes
- D. Traffic nodes

T6D03

What type of switch is represented by component 3 in Figure T2?

- A. Single-pole single-throw
- B. Single-pole double-throw
- C. Double-pole single-throw
- D. Double-pole double-throw

T6D04

Which of the following can be used to display signal strength on a numeric scale?

- A. Potentiometer
- B. Transistor
- C. Meter
- D. Relay

T6C13

Which of the following is accurately represented in electrical circuit schematic diagrams?

- A. Wire lengths
- B. Physical appearance of components
- C. The way components are interconnected
- D. All of these choices are correct

T7A05

What is the name of a circuit that generates a signal of a desired frequency?

- A. Reactance modulator
- B. Product detector
- C. Low-pass filter
- D. Oscillator

T7A08

Which of the following describes combining speech with an RF carrier signal?

- A. Impedance matching
- B. Oscillation
- C. Modulation
- D. Low-pass filtering

T7A01

Which term describes the ability of a receiver to detect the presence of a signal?

- A. Linearity
- B. Sensitivity
- C. Selectivity
- D. Total Harmonic Distortion

T7A03

Which of the following is used to convert a radio signal from one frequency to another?

- A. Phase splitter
- B. Mixer
- C. Inverter
- D. Amplifier

T7A04

Which term describes the ability of a receiver to discriminate between multiple signals?

- A. Discrimination ratio
- B. Sensitivity
- C. Selectivity
- D. Harmonic Distortion

T7A11

Where is an RF preamplifier installed?

- A. Between the antenna and receiver
- B. At the output of the transmitter's power amplifier
- C. Between a transmitter and antenna tuner
- D. At the receiver's audio output

T7A06

What device takes the output of a low-powered 28 MHz SSB exciter and produces a 222 MHz output signal?

- A. High-pass filter
- B. Low-pass filter
- C. Transverter
- D. Phase converter

T3C05

Which of the following effects might cause radio signals to be heard despite obstructions between the transmitting and receiving stations?

- A. Knife-edge diffraction
- B. Faraday rotation
- C. Quantum tunneling
- D. Doppler shift

T3C10

What is the radio horizon?

- A. The distance over which two stations can communicate by direct path
- B. The distance from the ground to a horizontally mounted antenna
- C. The farthest point you can see when standing at the base of your antenna tower
- D. The shortest distance between two points on the Earth's surface

T3C11

Why do VHF and UHF radio signals usually travel somewhat farther than the visual line of sight distance between two stations?

- A. Radio signals move somewhat faster than the speed of light
- B. Radio waves are not blocked by dust particles
- C. The Earth seems less curved to radio waves than to light
- D. Radio waves are blocked by dust particles

T3A01

What should you do if another operator reports that your station's 2 meter signals were strong just a moment ago, but now they are weak or distorted?

- A. Change the batteries in your radio to a different type
- B. Turn on the CTCSS tone
- C. Ask the other operator to adjust his squelch control
- D. Try moving a few feet or changing the direction of your antenna if possible, as reflections may be causing multi-path distortion

T3A02

Why are UHF signals often more effective from inside buildings than VHF signals?

- A. VHF signals lose power faster over distance
- B. The shorter wavelength allows them to more easily penetrate the structure of buildings
- C. This is incorrect; VHF works better than UHF inside buildings
- D. UHF antennas are more efficient than VHF antennas

T3A06

What term is commonly used to describe the rapid fluttering sound sometimes heard from mobile stations that are moving while transmitting?

- A. Flip-flopping
- B. Picket fencing
- C. Frequency shifting
- D. Pulsing

T3A08

Which of the following is a likely cause of irregular fading of signals received by ionospheric reflection?

- A. Frequency shift due to Faraday rotation
- B. Interference from thunderstorms
- C. Random combining of signals arriving via different paths
- D. Intermodulation distortion

T3A10

What may occur if data signals propagate over multiple paths?

- A. Transmission rates can be increased by a factor equal to the number of separate paths observed
- B. Transmission rates must be decreased by a factor equal to the number of separate paths observed
- C. No significant changes will occur if the signals are transmitting using FM
- D. Error rates are likely to increase

T3C06

What mode is responsible for allowing over-the-horizon VHF and UHF communications to ranges of approximately 300 miles on a regular basis?

- A. Tropospheric scatter
- B. D layer refraction
- C. F2 layer refraction
- D. Faraday rotation

T3C08

What causes tropospheric ducting?

- A. Discharges of lightning during electrical storms
- B. Sunspots and solar flares
- C. Updrafts from hurricanes and tornadoes
- D. Temperature inversions in the atmosphere

T3A11

Which part of the atmosphere enables the propagation of radio signals around the world?

- A. The stratosphere
- B. The troposphere
- C. The ionosphere
- D. The magnetosphere

T3C01

Why are direct (not via a repeater) UHF signals rarely heard from stations outside your local coverage area?

- A. They are too weak to go very far
- B. FCC regulations prohibit them from going more than 50 miles
- C. UHF signals are usually not reflected by the ionosphere
- D. They collide with trees and shrubbery and fade out

T3C02

Which of the following might be happening when VHF signals are being received from long distances?

- A. Signals are being reflected from outer space
- B. Signals are arriving by sub-surface ducting
- C. Signals are being reflected by lightning storms in your area
- D. Signals are being refracted from a sporadic E layer

T3C03

What is a characteristic of VHF signals received via auroral reflection?

- A. Signals from distances of 10,000 or more miles are common
- B. The signals exhibit rapid fluctuations of strength and often sound distorted
- C. These types of signals occur only during winter nighttime hours
- D. These types of signals are generally strongest when your antenna is aimed west

T3C04

Which of the following propagation types is most commonly associated with occasional strong over-the-horizon signals on the 10, 6, and 2 meter bands?

- A. Backscatter
- B. Sporadic E
- C. D layer absorption
- D. Gray-line propagation

T3C09

What is generally the best time for long-distance 10 meter band propagation via the F layer?

- A. From dawn to shortly after sunset during periods of high sunspot activity
- B. From shortly after sunset to dawn during periods of high sunspot activity
- C. From dawn to shortly after sunset during periods of low sunspot activity
- D. From shortly after sunset to dawn during periods of low sunspot activity

T3C12

Which of the following bands may provide long distance communications during the peak of the sunspot cycle?

- A. Six or ten meters
- B. 23 centimeters
- C. 70 centimeters or 1.25 meters
- D. All of these choices are correct

T3C07

What band is best suited for communicating via meteor scatter?

- A. 10 meters
- B. 6 meters
- C. 2 meters
- D. 70 cm

T3A04

What can happen if the antennas at opposite ends of a VHF or UHF line of sight radio link are not using the same polarization?

- A. The modulation sidebands might become inverted
- B. Signals could be significantly weaker
- C. Signals have an echo effect on voices
- D. Nothing significant will happen

T3A07

What type of wave carries radio signals between transmitting and receiving stations?

- A. Electromagnetic
- B. Electrostatic
- C. Surface acoustic
- D. Magnetostrictive

T3A09

Which of the following results from the fact that skip signals refracted from the ionosphere are elliptically polarized?

- A. Digital modes are unusable
- B. Either vertically or horizontally polarized antennas may be used for transmission or reception
- C. FM voice is unusable
- D. Both the transmitting and receiving antennas must be of the same polarization

T3B02

What property of a radio wave is used to describe its polarization?

- A. The orientation of the electric field
- B. The orientation of the magnetic field
- C. The ratio of the energy in the magnetic field to the energy in the electric field
- D. The ratio of the velocity to the wavelength

T3B03

What are the two components of a radio wave?

- A. AC and DC
- B. Voltage and current
- C. Electric and magnetic fields
- D. Ionizing and non-ionizing radiation

T5C07

What is a usual name for electromagnetic waves that travel through space?

- A. Gravity waves
- B. Sound waves
- C. Radio waves
- D. Pressure waves

T9A02

Which of the following is true regarding vertical antennas?

- A. The magnetic field is perpendicular to the Earth
- B. The electric field is perpendicular to the Earth
- C. The phase is inverted
- D. The phase is reversed

T9A11

What is meant by the gain of an antenna?

- A. The additional power that is added to the transmitter power
- B. The additional power that is lost in the antenna when transmitting on a higher frequency
- C. The increase in signal strength in a specified direction when compared to a reference antenna
- D. The increase in impedance on receive or transmit compared to a reference antenna

T5B09

What is the approximate amount of change, measured in decibels (dB), of a power increase from 5 watts to 10 watts?

- A. 2 dB
- B. 3 dB
- C. 5 dB
- D. 10 dB

T5B10

What is the approximate amount of change, measured in decibels (dB), of a power decrease from 12 watts to 3 watts?

- A. -1 dB
- B. -3 dB
- C. -6 dB
- D. -9 dB

T5B11

What is the approximate amount of change, measured in decibels (dB), of a power increase from 20 watts to 200 watts?

- A. 10 dB
- B. 12 dB
- C. 18 dB
- D. 28 dB

T7C07

What happens to power lost in a feed line?

- A. It increases the SWR
- B. It comes back into your transmitter and could cause damage
- C. It is converted into heat
- D. It can cause distortion of your signal

T9B05

What generally happens as the frequency of a signal passing through coaxial cable is increased?

- A. The apparent SWR increases
- B. The reflected power increases
- C. The characteristic impedance increases
- D. The loss increases

T7C12

Which of the following is a common use of coaxial cable?

- A. Carrying dc power from a vehicle battery to a mobile radio
- B. Carrying RF signals between a radio and antenna
- C. Securing masts, tubing, and other cylindrical objects on towers
- D. Connecting data signals from a TNC to a computer

T9B02

What is the impedance of the most commonly used coaxial cable in typical amateur radio installations?

- A. 8 ohms
- B. 50 ohms
- C. 600 ohms
- D. 12 ohms

T9B03

Why is coaxial cable used more often than any other feed line for amateur radio antenna systems?

- A. It is easy to use and requires few special installation considerations
- B. It has less loss than any other type of feed line
- C. It can handle more power than any other type of feed line
- D. It is less expensive than any other types of feed line

T9B11

Which of the following types of feed line has the lowest loss at VHF and UHF?

- A. 50-ohm flexible coax
- B. Multi-conductor unbalanced cable
- C. Air-insulated hard line
- D. 75-ohm flexible coax

T7C03

What, in general terms, is standing wave ratio (SWR)?

- A. A measure of how well a load is matched to a transmission line
- B. The ratio of high to low impedance in a feed line
- C. The transmitter efficiency ratio
- D. An indication of the quality of your station's ground connection

T7C04

What reading on an SWR meter indicates a perfect impedance match between the antenna and the feed line?

- A. 2 to 1
- B. 1 to 3
- C. 1 to 1
- D. 10 to 1

T7C05

What is the approximate SWR value above which the protection circuits in most solid-state transmitters begin to reduce transmitter power?

- A. 2 to 1
- B. 1 to 2
- C. 6 to 1
- D. 10 to 1

T7C06

What does an SWR reading of 4:1 indicate?

- A. Loss of -4dB
- B. Good impedance match
- C. Gain of +4dB
- D. Impedance mismatch

T9B01

Why is it important to have a low SWR in an antenna system that uses coaxial cable feed line?

- A. To reduce television interference
- B. To allow the efficient transfer of power and reduce losses
- C. To prolong antenna life
- D. All of these choices are correct

T9B09

What might cause erratic changes in SWR readings?

- A. The transmitter is being modulated
- B. A loose connection in an antenna or a feed line
- C. The transmitter is being over-modulated
- D. Interference from other stations is distorting your signal

T9A03

Which of the following describes a simple dipole mounted so the conductor is parallel to the Earth's surface?

- A. A ground wave antenna
- B. A horizontally polarized antenna
- C. A rhombic antenna
- D. A vertically polarized antenna

T9A08

What is the approximate length, in inches, of a quarter-wavelength vertical antenna for 146 MHz?

- A. 112
- B. 50
- C. 19
- D. 12

T9A09

What is the approximate length, in inches, of a 6 meter 1/2-wavelength wire dipole antenna?

- A. 6
- B. 50
- C. 112
- D. 236

T9A10

In which direction is the radiation strongest from a half-wave dipole antenna in free space?

- A. Equally in all directions
- B. Off the ends of the antenna
- C. Broadside to the antenna
- D. In the direction of the feed line

T9A05

How would you change a dipole antenna to make it resonant on a higher frequency?

- A. Lengthen it
- B. Insert coils in series with radiating wires
- C. Shorten it
- D. Add capacitive loading to the ends of the radiating wires

T9A04

What is a disadvantage of the "rubber duck" antenna supplied with most handheld radio transceivers?

- A. It does not transmit or receive as effectively as a full-sized antenna
- B. It transmits a circularly polarized signal
- C. If the rubber end cap is lost it will unravel very quickly
- D. All of these choices are correct

T9A07

What is a good reason not to use a "rubber duck" antenna inside your car?

- A. Signals can be significantly weaker than when it is outside of the vehicle
- B. It might cause your radio to overheat
- C. The SWR might decrease, decreasing the signal strength
- D. All of these choices are correct

T9A12

What is a reason to use a properly mounted 5/8 wavelength antenna for VHF or UHF mobile service?

- A. It offers a lower angle of radiation and more gain than a 1/4 wavelength antenna and usually provides improved coverage
- B. It features a very high angle of radiation and is better for communicating via a repeater
- C. The 5/8 wavelength antenna completely eliminates distortion caused by reflected signals
- D. The 5/8 wavelength antenna offers a 10-times power gain over a 1/4 wavelength design

T9A13

Why are VHF or UHF mobile antennas often mounted in the center of the vehicle roof?

- A. Roof mounts have the lowest possible SWR of any mounting configuration
- B. Only roof mounting can guarantee a vertically polarized signal
- C. A roof mounted antenna normally provides the most uniform radiation pattern
- D. Roof mounted antennas are always the easiest to install

T9A14

Which of the following terms describes a type of loading when referring to an antenna?

- A. Inserting an inductor in the radiating portion of the antenna to make it electrically longer
- B. Inserting a resistor in the radiating portion of the antenna to make it resonant
- C. Installing a spring at the base of the antenna to absorb the effects of collisions with other objects
- D. Making the antenna heavier so it will resist wind effects when in motion

T3A05

When using a directional antenna, how might your station be able to access a distant repeater if buildings or obstructions are blocking the direct line of sight path?

- A. Change from vertical to horizontal polarization
- B. Try to find a path that reflects signals to the repeater
- C. Try the long path
- D. Increase the antenna SWR

T9A01

What is a beam antenna?

- A. An antenna built from aluminum I-beams
- B. An omnidirectional antenna invented by Clarence Beam
- C. An antenna that concentrates signals in one direction
- D. An antenna that reverses the phase of received signals

T3A03

What antenna polarization is normally used for long-distance weak-signal CW and SSB contacts using the VHF and UHF bands?

- A. Right-hand circular
- B. Left-hand circular
- C. Horizontal
- D. Vertical

T9A06

What type of antennas are the quad, Yagi, and dish?

- A. Non-resonant antennas
- B. Loop antennas
- C. Directional antennas
- D. Isotropic antennas

T7C09

Which of the following is the most common cause for failure of coaxial cables?

- A. Moisture contamination
- B. Gamma rays
- C. The velocity factor exceeds 1.0
- D. Overloading

T7C10

Why should the outer jacket of coaxial cable be resistant to ultraviolet light?

- A. Ultraviolet resistant jackets prevent harmonic radiation
- B. Ultraviolet light can increase losses in the cable's jacket
- C. Ultraviolet and RF signals can mix together, causing interference
- D. Ultraviolet light can damage the jacket and allow water to enter the cable

T9B10

What electrical difference exists between the smaller RG-58 and larger RG-8 coaxial cables?

- A. There is no significant difference between the two types
- B. RG-58 cable has less loss at a given frequency
- C. RG-8 cable has less loss at a given frequency
- D. RG-58 cable can handle higher power levels

T7C11

What is a disadvantage of air core coaxial cable when compared to foam or solid dielectric types?

- A. It has more loss per foot
- B. It cannot be used for VHF or UHF antennas
- C. It requires special techniques to prevent water absorption
- D. It cannot be used at below freezing temperatures

T7D08

Which of the following types of solder is best for radio and electronic use?

- A. Acid-core solder
- B. Silver solder
- C. Rosin-core solder
- D. Aluminum solder

T7D09

What is the characteristic appearance of a cold solder joint?

- A. Dark black spots
- B. A bright or shiny surface
- C. A grainy or dull surface
- D. A greenish tint

T9B06

Which of the following connectors is most suitable for frequencies above 400 MHz?

- A. A UHF (PL-259/SO-239) connector
- B. A Type N connector
- C. An RS-213 connector
- D. A DB-25 connector

T9B07

Which of the following is true of PL-259 type coax connectors?

- A. They are preferred for microwave operation
- B. They are water tight
- C. They are commonly used at HF frequencies
- D. They are a bayonet type connector

T9B08

Why should coax connectors exposed to the weather be sealed against water intrusion?

- A. To prevent an increase in feed line loss
- B. To prevent interference to telephones
- C. To keep the jacket from becoming loose
- D. All of these choices are correct

T4A05

Where should an in-line SWR meter be connected to monitor the standing wave ratio of the station antenna system?

- A. In series with the feed line, between the transmitter and antenna
- B. In series with the station's ground
- C. In parallel with the push-to-talk line and the antenna
- D. In series with the power supply cable, as close as possible to the radio

T7C08

What instrument other than an SWR meter could you use to determine if a feed line and antenna are properly matched?

- A. Voltmeter
- B. Ohmmeter
- C. Iambic pentameter
- D. Directional wattmeter

T9B04

What does an antenna tuner do?

- A. It matches the antenna system impedance to the transceiver's output impedance
- B. It helps a receiver automatically tune in weak stations
- C. It allows an antenna to be used on both transmit and receive
- D. It automatically selects the proper antenna for the frequency band being used

T7C02

Which of the following instruments can be used to determine if an antenna is resonant at the desired operating frequency?

- A. A VTVM
- B. An antenna analyzer
- C. A Q meter
- D. A frequency counter

T0A02

How does current flowing through the body cause a health hazard?

- A. By heating tissue
- B. It disrupts the electrical functions of cells
- C. It causes involuntary muscle contractions
- D. All of these choices are correct

T0A01

Which of the following is a safety hazard of a 12-volt storage battery?

- A. Touching both terminals with the hands can cause electrical shock
- B. Shorting the terminals can cause burns, fire, or an explosion
- C. RF emissions from the battery
- D. All of these choices are correct

T0A06

What is a good way to guard against electrical shock at your station?

- A. Use three-wire cords and plugs for all AC powered equipment
- B. Connect all AC powered station equipment to a common safety ground
- C. Use a circuit protected by a ground-fault interrupter
- D. All of these choices are correct

T0A11

What kind of hazard might exist in a power supply when it is turned off and disconnected?

- A. Static electricity could damage the grounding system
- B. Circulating currents inside the transformer might cause damage
- C. The fuse might blow if you remove the cover
- D. You might receive an electric shock from the charged stored in large capacitors

T0A03

What is connected to the green wire in a three-wire electrical AC plug?

- A. Neutral
- B. Hot
- C. Safety ground
- D. The white wire

T0A08

What safety equipment should always be included in home-built equipment that is powered from 120V AC power circuits?

- A. A fuse or circuit breaker in series with the AC hot conductor
- B. An AC voltmeter across the incoming power source
- C. An inductor in series with the AC power source
- D. A capacitor across the AC power source

T0B10

Which of the following is true concerning grounding conductors used for lightning protection?

- A. Only non-insulated wire must be used
- B. Wires must be carefully routed with precise right-angle bends
- C. Sharp bends must be avoided
- D. Common grounds must be avoided

T0B11

Which of the following establishes grounding requirements for an amateur radio tower or antenna?

- A. FCC Part 97 Rules
- B. Local electrical codes
- C. FAA tower lighting regulations
- D. Underwriters Laboratories' recommended practices

T0B12

Which of the following is good practice when installing ground wires on a tower for lightning protection?

- A. Put a loop in the ground connection to prevent water damage to the ground system
- B. Make sure that all bends in the ground wires are clean, right angle bends
- C. Ensure that connections are short and direct
- D. All of these choices are correct

T0A07

Which of these precautions should be taken when installing devices for lightning protection in a coaxial cable feed line?

- A. Include a parallel bypass switch for each protector so that it can be switched out of the circuit when running high power
- B. Include a series switch in the ground line of each protector to prevent RF overload from inadvertently damaging the protector
- C. Keep the ground wires from each protector separate and connected to station ground
- D. Ground all of the protectors to a common plate which is in turn connected to an external ground

T0C01

What type of radiation are VHF and UHF radio signals?

- A. Gamma radiation
- B. Ionizing radiation
- C. Alpha radiation
- D. Non-ionizing radiation

T0C12

How does RF radiation differ from ionizing radiation (radioactivity)?

- A. RF radiation does not have sufficient energy to cause genetic damage
- B. RF radiation can only be detected with an RF dosimeter
- C. RF radiation is limited in range to a few feet
- D. RF radiation is perfectly safe

T0C05

Why do exposure limits vary with frequency?

- A. Lower frequency RF fields have more energy than higher frequency fields
- B. Lower frequency RF fields do not penetrate the human body
- C. Higher frequency RF fields are transient in nature
- D. The human body absorbs more RF energy at some frequencies than at others

T0C07

What could happen if a person accidentally touched your antenna while you were transmitting?

- A. Touching the antenna could cause television interference
- B. They might receive a painful RF burn
- C. They might develop radiation poisoning
- D. All of these choices are correct

T0C02

Which of the following frequencies has the lowest value for Maximum Permissible Exposure limit?

- A. 3.5 MHz
- B. 50 MHz
- C. 440 MHz
- D. 1296 MHz

T0C10

Why is duty cycle one of the factors used to determine safe RF radiation exposure levels?

- A. It affects the average exposure of people to radiation
- B. It affects the peak exposure of people to radiation
- C. It takes into account the antenna feed line loss
- D. It takes into account the thermal effects of the final amplifier

T0C11

What is the definition of duty cycle during the averaging time for RF exposure?

- A. The difference between the lowest power output and the highest power output of a transmitter
- B. The difference between the PEP and average power output of a transmitter
- C. The percentage of time that a transmitter is transmitting
- D. The percentage of time that a transmitter is not transmitting

T0C13

If the averaging time for exposure is 6 minutes, how much power density is permitted if the signal is present for 3 minutes and absent for 3 minutes rather than being present for the entire 6 minutes?

- A. 3 times as much
- B. 1/2 as much
- C. 2 times as much
- D. There is no adjustment allowed for shorter exposure times

T0C03

What is the maximum power level that an amateur radio station may use at VHF frequencies before an RF exposure evaluation is required?

- A. 1500 watts PEP transmitter output
- B. 1 watt forward power
- C. 50 watts PEP at the antenna
- D. 50 watts PEP reflected power

T0C04

What factors affect the RF exposure of people near an amateur station antenna?

- A. Frequency and power level of the RF field
- B. Distance from the antenna to a person
- C. Radiation pattern of the antenna
- D. All of these choices are correct

T0C06

Which of the following is an acceptable method to determine that your station complies with FCC RF exposure regulations?

- A. By calculation based on FCC OET Bulletin 65
- B. By calculation based on computer modeling
- C. By measurement of field strength using calibrated equipment
- D. All of these choices are correct

T0C09

How can you make sure your station stays in compliance with RF safety regulations?

- A. By informing the FCC of any changes made in your station
- B. By re-evaluating the station whenever an item of equipment is changed
- C. By making sure your antennas have low SWR
- D. All of these choices are correct

T0C08

Which of the following actions might amateur operators take to prevent exposure to RF radiation in excess of FCC-supplied limits?

- A. Relocate antennas
- B. Relocate the transmitter
- C. Increase the duty cycle
- D. All of these choices are correct

T0B04

Which of the following is an important safety precaution to observe when putting up an antenna tower?

- A. Wear a ground strap connected to your wrist at all times
- B. Insulate the base of the tower to avoid lightning strikes
- C. Look for and stay clear of any overhead electrical wires
- D. All of these choices are correct

T0B06

What is the minimum safe distance from a power line to allow when installing an antenna?

- A. Half the width of your property
- B. The height of the power line above ground
- C. 1/2 wavelength at the operating frequency
- D. So that if the antenna falls unexpectedly, no part of it can come closer than 10 feet to the power wires

T0B09

Why should you avoid attaching an antenna to a utility pole?

- A. The antenna will not work properly because of induced voltages
- B. The utility company will charge you an extra monthly fee
- C. The antenna could contact high-voltage power wires
- D. All of these choices are correct

T0B01

When should members of a tower work team wear a hard hat and safety glasses?

- A. At all times except when climbing the tower
- B. At all times except when belted firmly to the tower
- C. At all times when any work is being done on the tower
- D. Only when the tower exceeds 30 feet in height

T0B02

What is a good precaution to observe before climbing an antenna tower?

- A. Make sure that you wear a grounded wrist strap
- B. Remove all tower grounding connections
- C. Put on a climbing harness and safety glasses
- D. All of the these choices are correct

T0B08

What is considered to be a proper grounding method for a tower?

- A. A single four-foot ground rod, driven into the ground no more than 12 inches from the base
- B. A ferrite-core RF choke connected between the tower and ground
- C. Separate eight-foot long ground rods for each tower leg, bonded to the tower and each other
- D. A connection between the tower base and a cold water pipe

T0B03

Under what circumstances is it safe to climb a tower without a helper or observer?

- A. When no electrical work is being performed
- B. When no mechanical work is being performed
- C. When the work being done is not more than 20 feet above the ground
- D. Never

T0B05

What is the purpose of a gin pole?

- A. To temporarily replace guy wires
- B. To be used in place of a safety harness
- C. To lift tower sections or antennas
- D. To provide a temporary ground

T0B07

Which of the following is an important safety rule to remember when using a crank-up tower?

- A. This type of tower must never be painted
- B. This type of tower must never be grounded
- C. This type of tower must never be climbed unless it is in the fully retracted position
- D. All of these choices are correct

T4A02

How might a computer be used as part of an amateur radio station?

- A. For logging contacts and contact information
- B. For sending and/or receiving CW
- C. For generating and decoding digital signals
- D. All of these choices are correct

T4B02

Which of the following can be used to enter the operating frequency on a modern transceiver?

- A. The keypad or VFO knob
- B. The CTCSS or DTMF encoder
- C. The Automatic Frequency Control
- D. All of these choices are correct

T4B04

What is a way to enable quick access to a favorite frequency on your transceiver?

- A. Enable the CTCSS tones
- B. Store the frequency in a memory channel
- C. Disable the CTCSS tones
- D. Use the scan mode to select the desired frequency

T4B01

What may happen if a transmitter is operated with the microphone gain set too high?

- A. The output power might be too high
- B. The output signal might become distorted
- C. The frequency might vary
- D. The SWR might increase

T7B01

What can you do if you are told your FM handheld or mobile transceiver is over-deviating?

- A. Talk louder into the microphone
- B. Let the transceiver cool off
- C. Change to a higher power level
- D. Talk farther away from the microphone

T7C01

What is the primary purpose of a dummy load?

- A. To prevent the radiation of signals when making tests
- B. To prevent over-modulation of your transmitter
- C. To improve the radiation from your antenna
- D. To improve the signal to noise ratio of your receiver

T7C13

What does a dummy load consist of?

- A. A high-gain amplifier and a TR switch
- B. A non-inductive resistor and a heat sink
- C. A low voltage power supply and a DC relay
- D. A 50 ohm reactance used to terminate a transmission line

T4A01

Which of the following is true concerning the microphone connectors on amateur transceivers?

- A. All transceivers use the same microphone connector type
- B. Some connectors include push-to-talk and voltages for powering the microphone
- C. All transceivers using the same connector type are wired identically
- D. Un-keyed connectors allow any microphone to be connected

T7A07

What is meant by term "PTT"?

- A. Pre-transmission tuning to reduce transmitter harmonic emission
- B. Precise tone transmissions used to limit repeater access to only certain signals
- C. A primary transformer tuner use to match antennas
- D. The push to talk function which switches between receive and transmit

T8D10

Which of the following can be used to transmit CW in the amateur bands?

- A. Straight Key
- B. Electronic Keyer
- C. Computer Keyboard
- D. All of these choices are correct

T2B03

Which of the following describes the muting of receiver audio controlled solely by the presence or absence of an RF signal?

- A. Tone squelch
- B. Carrier squelch
- C. CTCSS
- D. Modulated carrier

T4B03

What is the purpose of the squelch control on a transceiver?

- A. To set the highest level of volume desired
- B. To set the transmitter power level
- C. To adjust the automatic gain control
- D. To mute receiver output noise when no signal is being received

T4B05

Which of the following would reduce ignition interference to a receiver?

- A. Change frequency slightly
- B. Decrease the squelch setting
- C. Turn on the noise blanker
- D. Use the RIT control

T4B06

Which of the following controls could be used if the voice pitch of a single-sideband signal seems too high or low?

- A. The AGC or limiter
- B. The bandwidth selection
- C. The tone squelch
- D. The receiver RIT or clarifier

T4B07

What does the term "RIT" mean?

- A. Receiver Input Tone
- B. Receiver Incremental Tuning
- C. Rectifier Inverter Test
- D. Remote Input Transmitter

T4B08

What is the advantage of having multiple receive bandwidth choices on a multimode transceiver?

- A. Permits monitoring several modes at once
- B. Permits noise or interference reduction by selecting a bandwidth matching the mode
- C. Increases the number of frequencies that can be stored in memory
- D. Increases the amount of offset between receive and transmit frequencies

T4B09

Which of the following is an appropriate receive filter bandwidth to select in order to minimize noise and interference for SSB reception?

- A. 500 Hz
- B. 1000 Hz
- C. 2400 Hz
- D. 5000 Hz

T4B10

Which of the following is an appropriate receive filter bandwidth to select in order to minimize noise and interference for CW reception?

- A. 500 Hz
- B. 1000 Hz
- C. 2400 Hz
- D. 5000 Hz

T4B12

What is the function of automatic gain control or AGC?

- A. To keep received audio relatively constant
- B. To protect an antenna from lightning
- C. To eliminate RF on the station cabling
- D. An asymmetric goniometer control used for antenna matching

T7A10

What device increases the low-power output from a handheld transceiver?

- A. A voltage divider
- B. An RF power amplifier
- C. An impedance network
- D. All of these choices are correct

T8D01

Which of the following is an example of a digital communications method?

- A. Packet
- B. PSK31
- C. MFSK
- D. All of these choices are correct

T8D09

What code is used when sending CW in the amateur bands?

- A. Baudot
- B. Hamming
- C. International Morse
- D. Gray

T8D08

Which of the following may be included in packet transmissions?

- A. A check sum which permits error detection
- B. A header which contains the call sign of the station to which the information is being sent
- C. Automatic repeat request in case of error
- D. All of these choices are correct

T8D11

What is an ARQ transmission system?

- A. A special transmission format limited to video signals
- B. A system used to encrypt command signals to an amateur radio satellite
- C. A digital scheme whereby the receiving station detects errors and sends a request to the sending station to retransmit the information
- D. A method of compressing the data in a message so more information can be sent in a shorter time

T8D02

What does the term "APRS" mean?

- A. Automatic Packet Reporting System
- B. Associated Public Radio Station
- C. Auto Planning Radio Set-up
- D. Advanced Polar Radio System

T8D03

Which of the following devices provides data to the transmitter when sending automatic position reports from a mobile amateur radio station?

- A. The vehicle speedometer
- B. A WWV receiver
- C. A connection to a broadcast FM sub-carrier receiver
- D. A Global Positioning System receiver

T8D05

Which of the following is an application of APRS (Automatic Packet Reporting System)?

- A. Providing real time tactical digital communications in conjunction with a map showing the locations of stations
- B. Showing automatically the number of packets transmitted via PACTOR during a specific time interval
- C. Providing voice over Internet connection between repeaters
- D. Providing information on the number of stations signed into a repeater

T8D06

What does the abbreviation PSK mean?

- A. Pulse Shift Keying
- B. Phase Shift Keying
- C. Packet Short Keying
- D. Phased Slide Keying

T8D07

What is PSK31?

- A. A high-rate data transmission mode
- B. A method of reducing noise interference to FM signals
- C. A method of compressing digital television signals
- D. A low-rate data transmission mode

T4A06

Which of the following would be connected between a transceiver and computer in a packet radio station?

- A. Transmatch
- B. Mixer
- C. Terminal node controller
- D. Antenna

T4A07

How is a computer's sound card used when conducting digital communications using a computer?

- A. The sound card communicates between the computer CPU and the video display
- B. The sound card records the audio frequency for video display
- C. The sound card provides audio to the microphone input and converts received audio to digital form
- D. All of these choices are correct

T8C11

What name is given to an amateur radio station that is used to connect other amateur stations to the Internet?

- A. A gateway
- B. A repeater
- C. A digipeater
- D. A beacon

T4A03

Which is a good reason to use a regulated power supply for communications equipment?

- A. It prevents voltage fluctuations from reaching sensitive circuits
- B. A regulated power supply has FCC approval
- C. A fuse or circuit breaker regulates the power
- D. Power consumption is independent of load

T4A11

Where should the negative return connection of a mobile transceiver's power cable be connected?

- A. At the battery or engine block ground strap
- B. At the antenna mount
- C. To any metal part of the vehicle
- D. Through the transceiver's mounting bracket

T5A06

How much voltage does a mobile transceiver usually require?

- A. About 12 volts
- B. About 30 volts
- C. About 120 volts
- D. About 240 volts

T6D05

What type of circuit controls the amount of voltage from a power supply?

- A. Regulator
- B. Oscillator
- C. Filter
- D. Phase inverter

T4A10

What is the source of a high-pitched whine that varies with engine speed in a mobile transceiver's receive audio?

- A. The ignition system
- B. The alternator
- C. The electric fuel pump
- D. Anti-lock braking system controllers

T4A12

What could be happening if another operator reports a variable high-pitched whine on the audio from your mobile transmitter?

- A. Your microphone is picking up noise from an open window
- B. You have the volume on your receiver set too high
- C. You need to adjust your squelch control
- D. Noise on the vehicle's electrical system is being transmitted along with your speech audio

T6A10

Which of the following battery types is rechargeable?

- A. Nickel-metal hydride
- B. Lithium-ion
- C. Lead-acid gel-cell
- D. All of these choices are correct

T6A11

Which of the following battery types is not rechargeable?

- A. Nickel-cadmium
- B. Carbon-zinc
- C. Lead-acid
- D. Lithium-ion

T0A09

What kind of hazard is presented by a conventional 12-volt storage battery?

- A. It emits ozone which can be harmful to the atmosphere
- B. Shock hazard due to high voltage
- C. Explosive gas can collect if not properly vented
- D. All of these choices are correct

T0A10

What can happen if a lead-acid storage battery is charged or discharged too quickly?

- A. The battery could overheat and give off flammable gas or explode
- B. The voltage can become reversed
- C. The memory effect will reduce the capacity of the battery
- D. All of these choices are correct

T2C02

What is one way to recharge a 12-volt lead-acid station battery if the commercial power is out?

- A. Cool the battery in ice for several hours
- B. Add acid to the battery
- C. Connect the battery in parallel with a vehicle's battery and run the engine
- D. All of these choices are correct

T7B03

Which of the following may be a cause of radio frequency interference?

- A. Fundamental overload
- B. Harmonics
- C. Spurious emissions
- D. All of these choices are correct

T7B07

Which of the following may be useful in correcting a radio frequency interference problem?

- A. Snap-on ferrite chokes
- B. Low-pass and high-pass filters
- C. Band-reject and band-pass filters
- D. All of these choices are correct

T4A09

Which of the following could you use to cure distorted audio caused by RF current flowing on the shield of a microphone cable?

- A. Band-pass filter
- B. Low-pass filter
- C. Preamplifier
- D. Ferrite choke

T4A04

Where must a filter be installed to reduce harmonic emissions from your station?

- A. Between the transmitter and the antenna
- B. Between the receiver and the transmitter
- C. At the station power supply
- D. At the microphone

T7B02

What would cause a broadcast AM or FM radio to receive an amateur radio transmission unintentionally?

- A. The receiver is unable to reject strong signals outside the AM or FM band
- B. The microphone gain of the transmitter is turned up too high
- C. The audio amplifier of the transmitter is overloaded
- D. The deviation of an FM transmitter is set too low

T7B04

Which of the following is a way to reduce or eliminate interference by an amateur transmitter to a nearby telephone?

- A. Put a filter on the amateur transmitter
- B. Reduce the microphone gain
- C. Reduce the SWR on the transmitter transmission line
- D. Put a RF filter on the telephone

T7B05

How can overload of a non-amateur radio or TV receiver by an amateur signal be reduced or eliminated?

- A. Block the amateur signal with a filter at the antenna input of the affected receiver
- B. Block the interfering signal with a filter on the amateur transmitter
- C. Switch the transmitter from FM to SSB
- D. Switch the transmitter to a narrow-band mode

T7B12

What might be the first step to resolve cable TV interference from your ham radio transmission?

- A. Add a low pass filter to the TV antenna input
- B. Add a high pass filter to the TV antenna input
- C. Add a preamplifier to the TV antenna input
- D. Be sure all TV coaxial connectors are installed properly

T6D12

Which of the following is a common reason to use shielded wire?

- A. To decrease the resistance of DC power connections
- B. To increase the current carrying capability of the wire
- C. To prevent coupling of unwanted signals to or from the wire
- D. To couple the wire to other signals

T7B06

Which of the following actions should you take if a neighbor tells you that your station's transmissions are interfering with their radio or TV reception?

- A. Make sure that your station is functioning properly and that it does not cause interference to your own radio or television when it is tuned to the same channel
- B. Immediately turn off your transmitter and contact the nearest FCC office for assistance
- C. Tell them that your license gives you the right to transmit and nothing can be done to reduce the interference
- D. Install a harmonic doubler on the output of your transmitter and tune it until the interference is eliminated

T7B08

What should you do if something in a neighbor's home is causing harmful interference to your amateur station?

- A. Work with your neighbor to identify the offending device
- B. Politely inform your neighbor about the rules that prohibit the use of devices which cause interference
- C. Check your station and make sure it meets the standards of good amateur practice
- D. All of these choices are correct

T7B09

What is a Part 15 device?

- A. An unlicensed device that may emit low powered radio signals on frequencies used by a licensed service
- B. A type of amateur radio that can legally be used in the citizen's band
- C. A device for long distance communications using special codes sanctioned by the International Amateur Radio Union
- D. A type of test set used to determine whether a transmitter is in compliance with FCC regulation 91.15

T7B11

What is a symptom of RF feedback in a transmitter or transceiver?

- A. Excessive SWR at the antenna connection
- B. The transmitter will not stay on the desired frequency
- C. Reports of garbled, distorted, or unintelligible transmissions
- D. Frequent blowing of power supply fuses

T4A08

Which type of conductor is best to use for RF grounding?

- A. Round stranded wire
- B. Round copper-clad steel wire
- C. Twisted-pair cable
- D. Flat strap

T1E01 [97.7(a)]

When is an amateur station permitted to transmit without a control operator?

- A. When using automatic control, such as in the case of a repeater
- B. When the station licensee is away and another licensed amateur is using the station
- C. When the transmitting station is an auxiliary station
- D. Never

T1E03 [97.103(b)]

Who must designate the station control operator?

- A. The station licensee
- B. The FCC
- C. The frequency coordinator
- D. The ITU

T1E02 [97.7(a)]

Who may a station licensee designate to be the control operator of an amateur station?

- A. Any U.S. citizen or registered alien
- B. Any family member of the station licensee
- C. Any person over the age of 18
- D. Only a person for whom an amateur operator/primary station license grant appears in the FCC database or who is authorized for alien reciprocal operation

T1E04 [97.103(b)]

What determines the transmitting privileges of an amateur station?

- A. The frequency authorized by the frequency coordinator
- B. The class of operator license held by the station licensee
- C. The highest class of operator license held by anyone on the premises
- D. The class of operator license held by the control operator

T1E05 [97.3(a)(14)]

What is an amateur station control point?

- A. The location of the station's transmitting antenna
- B. The location of the station transmitting apparatus
- C. The location at which the control operator function is performed
- D. The mailing address of the station licensee

T1E07 [97.103(a)]

When the control operator is not the station licensee, who is responsible for the proper operation of the station?

- A. All licensed amateurs who are present at the operation
- B. Only the station licensee
- C. Only the control operator
- D. The control operator and the station licensee are equally responsible

T1E11 [97.103(a)]

Who does the FCC presume to be the control operator of an amateur station, unless documentation to the contrary is in the station records?

- A. The station custodian
- B. The third party participant
- C. The person operating the station equipment
- D. The station licensee

T1E12 [97.119(e)]

When, under normal circumstances, may a Technician Class licensee be the control operator of a station operating in an exclusive Extra Class operator segment of the amateur bands?

- A. At no time
- B. When operating a special event station
- C. As part of a multi-operator contest team
- D. When using a club station whose trustee is an Extra Class operator licensee

T1D11 [97.119(a)]

When may an amateur station transmit without identifying?

- A. When the transmissions are of a brief nature to make station adjustments
- B. When the transmissions are unmodulated
- C. When the transmitted power level is below 1 watt
- D. When transmitting signals to control a model craft

T1F03 [97.119(a)]

When is an amateur station required to transmit its assigned call sign?

- A. At the beginning of each contact, and every 10 minutes thereafter
- B. At least once during each transmission
- C. At least every 15 minutes during and at the end of a communication
- D. At least every 10 minutes during and at the end of a communication

T1F01

What type of identification is being used when identifying a station on the air as Race Headquarters?

- A. Tactical call sign
- B. An official call sign reserved for RACES drills
- C. SSID
- D. Broadcast station

T1F02 [97.119 (a)]

When using tactical identifiers such as "Race Headquarters" during a community service net operation, how often must your station transmit the station's FCC-assigned call sign?

- A. Never, the tactical call is sufficient
- B. Once during every hour
- C. At the end of each communication and every ten minutes during a communication
- D. At the end of every transmission

T1F04 [97.119(b)(2)]

Which of the following is an acceptable language to use for station identification when operating in a phone sub-band?

- A. Any language recognized by the United Nations
- B. Any language recognized by the ITU
- C. The English language
- D. English, French, or Spanish

T1F05 [97.119(b)(2)]

What method of call sign identification is required for a station transmitting phone signals?

- A. Send the call sign followed by the indicator RPT
- B. Send the call sign using CW or phone emission
- C. Send the call sign followed by the indicator R
- D. Send the call sign using only phone emission

T1F06 [97.119(c)]

Which of the following formats of a self-assigned indicator is acceptable when identifying using a phone transmission?

- A. KL7CC stroke W3
- B. KL7CC slant W3
- C. KL7CC slash W3
- D. All of these choices are correct

T2B09 [97.119(b)(2)]

Which of the following methods is encouraged by the FCC when identifying your station when using phone?

- A. Use of a phonetic alphabet
- B. Send your call sign in CW as well as voice
- C. Repeat your call sign three times
- D. Increase your signal to full power when identifying

T1F08 [97.119(f)]

Which indicator is required by the FCC to be transmitted after a station call sign?

- A. /M when operating mobile
- B. /R when operating a repeater
- C. / followed the FCC Region number when operating out of the region in which the license was issued
- D. /KT, /AE or /AG when using new license privileges earned by CSCE while waiting for an upgrade to a previously issued license to appear in the FCC license database

T2A06

What must an amateur operator do when making on-air transmissions to test equipment or antennas?

- A. Properly identify the transmitting station
- B. Make test transmissions only after 10:00 p.m. local time
- C. Notify the FCC of the test transmission
- D. State the purpose of the test during the test procedure

T2A07

Which of the following is true when making a test transmission?

- A. Station identification is not required if the transmission is less than 15 seconds
- B. Station identification is not required if the transmission is less than 1 watt
- C. Station identification is only required once an hour when the transmissions are for test purposes only
- D. Station identification is required at least every ten minutes during the test and at the end of the test

T1A04 [97.3(a)(23)]

Which of the following meets the FCC definition of harmful interference?

- A. Radio transmissions that annoy users of a repeater
- B. Unwanted radio transmissions that cause costly harm to radio station apparatus
- C. That which seriously degrades, obstructs, or repeatedly interrupts a radio communication service operating in accordance with the Radio Regulations
- D. Static from lightning storms

T1A06 [97.101 (d), 97.303 (o)(2)]

Which of the following services are protected from interference by amateur signals under all circumstances?

- A. Citizens Radio Service
- B. Broadcast Service
- C. Land Mobile Radio Service
- D. Radionavigation Service

T2B08

Which of the following applies when two stations transmitting on the same frequency interfere with each other?

- A. Common courtesy should prevail, but no one has absolute right to an amateur frequency
- B. Whoever has the strongest signal has priority on the frequency
- C. Whoever has been on the frequency the longest has priority on the frequency
- D. The station which has the weakest signal has priority on the frequency

T1A11 [97.101 (d)]

When is willful interference to other amateur radio stations permitted?

- A. Only if the station being interfered with is expressing extreme religious or political views
- B. At no time
- C. Only during a contest
- D. At any time, amateurs are not protected from willful interference

T1F11 [97.115(a)]

To which foreign stations do the FCC rules authorize the transmission of non-emergency third party communications?

- A. Any station whose government permits such communications
- B. Those in ITU Region 2 only
- C. Those in ITU Regions 2 and 3 only
- D. Those in ITU Region 3 only

T1E09 [97.109(b)]

What type of control is being used when the control operator is at the control point?

- A. Radio control
- B. Unattended control
- C. Automatic control
- D. Local control

T1E10 [97.3(a)(39)]

Which of the following is an example of remote control as defined in Part 97?

- A. Repeater operation
- B. Operating the station over the Internet
- C. Controlling a model aircraft, boat or car by amateur radio
- D. All of these choices are correct

T1F07 [97.115(a)(2)]

Which of the following restrictions apply when a non-licensed person is allowed to speak to a foreign station using a station under the control of a Technician Class control operator?

- A. The person must be a U.S. citizen
- B. The foreign station must be one with which the U.S. has a third party agreement
- C. The licensed control operator must do the station identification
- D. All of these choices are correct

T1D06 [97.113(a)(4)]

What, if any, are the restrictions concerning transmission of language that may be considered indecent or obscene?

- A. The FCC maintains a list of words that are not permitted to be used on amateur frequencies
- B. Any such language is prohibited
- C. The ITU maintains a list of words that are not permitted to be used on amateur frequencies
- D. There is no such prohibition

T1E06 [97.109(d)]

Under what type of control do APRS network digipeaters operate?

- A. Automatic
- B. Remote
- C. Local
- D. Manual

T1E08 [97.3(a)(6), 97.205(d)]

Which of the following is an example of automatic control?

- A. Repeater operation
- B. Controlling the station over the Internet
- C. Using a computer or other device to automatically send CW
- D. Using a computer or other device to automatically identify

T1F10 [97.205(g)]

Who is accountable should a repeater inadvertently retransmit communications that violate the FCC rules?

- A. The control operator of the originating station
- B. The control operator of the repeater
- C. The owner of the repeater
- D. Both the originating station and the repeater owner

T1D03 [97.211(b), 97.215(b)]

When is the transmission of codes or ciphers that hide the meaning of a message allowed by an amateur station?

- A. Only during contests
- B. Only when operating mobile
- C. Only when transmitting control commands to space stations or radio control craft
- D. Only when frequencies above 1280 MHz are used

T1D05 [97.113(a)(3)(ii)]

When may amateur radio operators use their stations to notify other amateurs of the availability of equipment for sale or trade?

- A. When the equipment is normally used in an amateur station and such activity is not conducted on a regular basis
- B. When the asking price is \$100.00 or less
- C. When the asking price is less than its appraised value
- D. When the equipment is not the personal property of either the station licensee or the control operator or their close relatives

T1D08 [97.113(a)(3)(iii)]

In which of the following circumstances may the control operator of an amateur station receive compensation for operating the station?

- A. When engaging in communications on behalf of their employer
- B. When the communication is incidental to classroom instruction at an educational institution
- C. When re-broadcasting weather alerts during a RACES net
- D. When notifying other amateur operators of the availability for sale or trade of apparatus

T1D02 [97.111(a)(5)]

On which of the following occasions may an FCC-licensed amateur station exchange messages with a U.S. military station?

- A. During an Armed Forces Day Communications Test
- B. During a Memorial Day Celebration
- C. During an Independence Day celebration
- D. During a propagation test

T1D04 [97.113(a)(4), 97.113(c)]

What is the only time an amateur station is authorized to transmit music?

- A. When incidental to an authorized retransmission of manned spacecraft communications
- B. When the music produces no spurious emissions
- C. When the purpose is to interfere with an illegal transmission
- D. When the music is transmitted above 1280 MHz

T1D07 [97.113(d)]

What types of amateur stations can automatically retransmit the signals of other amateur stations?

- A. Auxiliary, beacon, or Earth stations
- B. Auxiliary, repeater, or space stations
- C. Beacon, repeater, or space stations
- D. Earth, repeater, or space stations

T1D09 [97.113(5)(b)]

Under which of the following circumstances are amateur stations authorized to transmit signals related to broadcasting, program production, or news gathering, assuming no other means is available?

- A. Only where such communications directly relate to the immediate safety of human life or protection of property
- B. Only when broadcasting communications to or from the space shuttle
- C. Only where noncommercial programming is gathered and supplied exclusively to the National Public Radio network
- D. Only when using amateur repeaters linked to the Internet

T1D10 [97.3(a)(10)]

What is the meaning of the term "broadcasting" in the FCC rules for the amateur services?

- A. Two-way transmissions by amateur stations
- B. Transmission of music
- C. Transmission of messages directed only to amateur operators
- D. Transmissions intended for reception by the general public

T1D12 [97.111(b)(4-6)]

Under which of the following circumstances may an amateur radio station engage in broadcasting?

- A. Under no circumstances
- B. When transmitting code practice, information bulletins, or transmissions necessary to provide emergency communications
- C. At any time as long as no music is transmitted
- D. At any time as long as the material being transmitted did not originate from a commercial broadcast station

T8C05

What is a grid locator?

- A. A letter-number designator assigned to a geographic location
- B. A letter-number designator assigned to an azimuth and elevation
- C. An instrument for neutralizing a final amplifier
- D. An instrument for radio direction finding

T2B10

Which Q signal indicates that you are receiving interference from other stations?

- A. QRM
- B. QRN
- C. QTH
- D. QSB

T2B11

Which Q signal indicates that you are changing frequency?

- A. QRU
- B. QSY
- C. QSL
- D. QRZ

T2B01

What is the term used to describe an amateur station that is transmitting and receiving on the same frequency?

- A. Full duplex communication
- B. Diplex communication
- C. Simplex communication
- D. Multiplex communication

T2B13

Which of the following is true of the use of SSB phone in amateur bands above 50 MHz?

- A. It is permitted only by holders of a General Class or higher license
- B. It is permitted only on repeaters
- C. It is permitted in at least some portion of all the amateur bands above 50 MHz
- D. It is permitted only on when power is limited to no more than 100 watts

T2A09

What brief statement is often transmitted in place of "CQ" to indicate that you are listening on a repeater?

- A. The words "Hello test" followed by your call sign
- B. Your call sign
- C. The repeater call sign followed by your call sign
- D. The letters "QSY" followed by your call sign

T2A04

What is an appropriate way to call another station on a repeater if you know the other station's call sign?

- A. Say break, break then say the station's call sign
- B. Say the station's call sign then identify with your call sign
- C. Say CQ three times then the other station's call sign
- D. Wait for the station to call CQ then answer it

T7B10

What might be the problem if you receive a report that your audio signal through the repeater is distorted or unintelligible?

- A. Your transmitter may be slightly off frequency
- B. Your batteries may be running low
- C. You could be in a bad location
- D. All of these choices are correct

T2A05

How should you respond to a station calling CQ?

- A. Transmit CQ followed by the other station's call sign
- B. Transmit your call sign followed by the other station's call sign
- C. Transmit the other station's call sign followed by your call sign
- D. Transmit a signal report followed by your call sign

T2A08

What is the meaning of the procedural signal "CQ"?

- A. Call on the quarter hour
- B. A new antenna is being tested (no station should answer)
- C. Only the called station should transmit
- D. Calling any station

T2A12

Which of the following is a guideline to use when choosing an operating frequency for calling CQ?

- A. Listen first to be sure that no one else is using the frequency
- B. Ask if the frequency is in use
- C. Make sure you are in your assigned band
- D. All of these choices are correct

T2A02

What is the national calling frequency for FM simplex operations in the 70 cm band?

- A. 146.520 MHz
- B. 145.000 MHz
- C. 432.100 MHz
- D. 446.000 MHz

T2B12

Under what circumstances should you consider communicating via simplex rather than a repeater?

- A. When the stations can communicate directly without using a repeater
- B. Only when you have an endorsement for simplex operation on your license
- C. Only when third party traffic is not being passed
- D. Only if you have simplex modulation capability

T2A01

What is the most common repeater frequency offset in the 2 meter band?

- A. Plus 500 kHz
- B. Plus or minus 600 kHz
- C. Minus 500 kHz
- D. Only plus 600 kHz

T2A03

What is a common repeater frequency offset in the 70 cm band?

- A. Plus or minus 5 MHz
- B. Plus or minus 600 kHz
- C. Minus 600 kHz
- D. Plus 600 kHz

T2B02

What is the term used to describe the use of a sub-audible tone transmitted with normal voice audio to open the squelch of a receiver?

- A. Carrier squelch
- B. Tone burst
- C. DTMF
- D. CTCSS

T4B11

Which of the following describes the common meaning of the term "repeater offset"?

- A. The distance between the repeater's transmit and receive antennas
- B. The time delay before the repeater timer resets
- C. The difference between the repeater's transmit and receive frequencies
- D. Matching the antenna impedance to the feed line impedance

T2B04

Which of the following common problems might cause you to be able to hear but not access a repeater even when transmitting with the proper offset?

- A. The repeater receiver may require an audio tone burst for access
- B. The repeater receiver may require a CTCSS tone for access
- C. The repeater receiver may require a DCS tone sequence for access
- D. All of these choices are correct

T8C13

What is the Internet Radio Linking Project (IRLP)?

- A. A technique to connect amateur radio systems, such as repeaters, via the Internet using Voice Over Internet Protocol
- B. A system for providing access to websites via amateur radio
- C. A system for informing amateurs in real time of the frequency of active DX stations
- D. A technique for measuring signal strength of an amateur transmitter via the Internet

T8C06

How is access to an IRLP node accomplished?

- A. By obtaining a password which is sent via voice to the node
- B. By using DTMF signals
- C. By entering the proper Internet password
- D. By using CTCSS tone codes

T8C09

How might you obtain a list of active nodes that use VoIP?

- A. From the FCC Rulebook
- B. From your local emergency coordinator
- C. From a repeater directory
- D. From the local repeater frequency coordinator

T8C10

How do you select a specific IRLP node when using a portable transceiver?

- A. Choose a specific CTCSS tone
- B. Choose the correct DSC tone
- C. Access the repeater autopatch
- D. Use the keypad to transmit the IRLP node ID

T8C12

What is meant by Voice Over Internet Protocol (VoIP) as used in amateur radio?

- A. A set of rules specifying how to identify your station when linked over the Internet to another station
- B. A set of guidelines for working DX during contests using Internet access
- C. A technique for measuring the modulation quality of a transmitter using remote sites monitored via the Internet
- D. A method of delivering voice communications over the Internet using digital techniques

T2C06

Which of the following is an accepted practice to get the immediate attention of a net control station when reporting an emergency?

- A. Repeat the words SOS three times followed by the call sign of the reporting station
- B. Press the push-to-talk button three times
- C. Begin your transmission by saying "Priority" or "Emergency" followed by your call sign
- D. Play a pre-recorded emergency alert tone followed by your call sign

T2C07

Which of the following is an accepted practice for an amateur operator who has checked into an emergency traffic net?

- A. Provided that the frequency is quiet, announce the station call sign and location every 5 minutes
- B. Move 5 kHz away from the net's frequency and use high power to ask other hams to keep clear of the net frequency
- C. Remain on frequency without transmitting until asked to do so by the net control station
- D. All of the choices are correct

T2C03

What should be done to insure that voice message traffic containing proper names and unusual words are copied correctly by the receiving station?

- A. The entire message should be repeated at least four times
- B. Such messages must be limited to no more than 10 words
- C. Such words and terms should be spelled out using a standard phonetic alphabet
- D. All of these choices are correct

T2C08

Which of the following is a characteristic of good emergency traffic handling?

- A. Passing messages exactly as received
- B. Making decisions as to whether or not messages should be relayed or delivered
- C. Communicating messages to the news media for broadcast outside the disaster area
- D. All of these choices are correct

T2C10

What is the preamble in a formal traffic message?

- A. The first paragraph of the message text
- B. The message number
- C. The priority handling indicator for the message
- D. The information needed to track the message as it passes through the amateur radio traffic handling system

T2C11

What is meant by the term "check" in reference to a formal traffic message?

- A. The check is a count of the number of words or word equivalents in the text portion of the message
- B. The check is the value of a money order attached to the message
- C. The check is a list of stations that have relayed the message
- D. The check is a box on the message form that tells you the message was received

T2C04

What do RACES and ARES have in common?

- A. They represent the two largest ham clubs in the United States
- B. Both organizations broadcast road and weather information
- C. Neither may handle emergency traffic supporting public service agencies
- D. Both organizations may provide communications during emergencies

T2C05 [97.3(a)(38), 97.407]

Which of the following describes the Radio Amateur Civil Emergency Service (RACES)?

- A. A radio service using amateur frequencies for emergency management or civil defense communications
- B. A radio service using amateur stations for emergency management or civil defense communications
- C. An emergency service using amateur operators certified by a civil defense organization as being enrolled in that organization
- D. All of these choices are correct

T2C12

What is the Amateur Radio Emergency Service (ARES)?

- A. Licensed amateurs who have voluntarily registered their qualifications and equipment for communications duty in the public service
- B. Licensed amateurs who are members of the military and who voluntarily agreed to provide message handling services in the case of an emergency
- C. A training program that provides licensing courses for those interested in obtaining an amateur license to use during emergencies
- D. A training program that certifies amateur operators for membership in the Radio Amateur Civil Emergency Service

T2C01 [97.103(a)]

When do the FCC rules NOT apply to the operation of an amateur station?

- A. When operating a RACES station
- B. When operating under special FEMA rules
- C. When operating under special ARES rules
- D. Never, FCC rules always apply

T2C09

Are amateur station control operators ever permitted to operate outside the frequency privileges of their license class?

- A. No
- B. Yes, but only when part of a FEMA emergency plan
- C. Yes, but only when part of a RACES emergency plan
- D. Yes, but only if necessary in situations involving the immediate safety of human life or protection of property

T7A09

Which of the following devices is most useful for VHF weak-signal communication?

- A. A quarter-wave vertical antenna
- B. A multi-mode VHF transceiver
- C. An omni-directional antenna
- D. A mobile VHF FM transceiver

T8C03

What popular operating activity involves contacting as many stations as possible during a specified period of time?

- A. Contesting
- B. Net operations
- C. Public service events
- D. Simulated emergency exercises

T8C04

Which of the following is good procedure when contacting another station in a radio contest?

- A. Be sure to sign only the last two letters of your call if there is a pileup calling the station
- B. Work the station twice to be sure that you are in his log
- C. Send only the minimum information needed for proper identification and the contest exchange
- D. All of these choices are correct

T8C01

Which of the following methods is used to locate sources of noise interference or jamming?

- A. Echolocation
- B. Doppler radar
- C. Radio direction finding
- D. Phase locking

T8C02

Which of these items would be useful for a hidden transmitter hunt?

- A. Calibrated SWR meter
- B. A directional antenna
- C. A calibrated noise bridge
- D. All of these choices are correct

T8B01 [97.301, 97.207(c)]

Who may be the control operator of a station communicating through an amateur satellite or space station?

- A. Only an Amateur Extra Class operator
- B. A General Class licensee or higher licensee who has a satellite operator certification
- C. Only an Amateur Extra Class operator who is also an AMSAT member
- D. Any amateur whose license privileges allow them to transmit on the satellite uplink frequency

T8B04 [97.301, 97.207(c)]

Which amateur stations may make contact with an amateur station on the International Space Station using 2 meter and 70 cm band amateur radio frequencies?

- A. Only members of amateur radio clubs at NASA facilities
- B. Any amateur holding a Technician or higher class license
- C. Only the astronaut's family members who are hams
- D. You cannot talk to the ISS on amateur radio frequencies

T8B05

What is a satellite beacon?

- A. The primary transmit antenna on the satellite
- B. An indicator light that shows where to point your antenna
- C. A reflective surface on the satellite
- D. A transmission from a space station that contains information about a satellite

T8B07

With regard to satellite communications, what is Doppler shift?

- A. A change in the satellite orbit
- B. A mode where the satellite receives signals on one band and transmits on another
- C. An observed change in signal frequency caused by relative motion between the satellite and the earth station
- D. A special digital communications mode for some satellites

T8B10

What do the initials LEO tell you about an amateur satellite?

- A. The satellite battery is in Low Energy Operation mode
- B. The satellite is performing a Lunar Ejection Orbit maneuver
- C. The satellite is in a Low Earth Orbit
- D. The satellite uses Light Emitting Optics

T8B02 [97.313]

How much transmitter power should be used on the uplink frequency of an amateur satellite or space station?

- A. The maximum power of your transmitter
- B. The minimum amount of power needed to complete the contact
- C. No more than half the rating of your linear amplifier
- D. Never more than 1 watt

T8B03

Which of the following are provided by satellite tracking programs?

- A. Maps showing the real-time position of the satellite track over the earth
- B. The time, azimuth, and elevation of the start, maximum altitude, and end of a pass
- C. The apparent frequency of the satellite transmission, including effects of Doppler shift
- D. All of these answers are correct

T8B06

Which of the following are inputs to a satellite tracking program?

- A. The weight of the satellite
- B. The Keplerian elements
- C. The last observed time of zero Doppler shift
- D. All of these answers are correct

T8B08

What is meant by the statement that a satellite is operating in mode U/V?

- A. The satellite uplink is in the 15 meter band and the downlink is in the 10 meter band
- B. The satellite uplink is in the 70 cm band and the downlink is in the 2 meter band
- C. The satellite operates using ultraviolet frequencies
- D. The satellite frequencies are usually variable

T8B09

What causes spin fading when referring to satellite signals?

- A. Circular polarized noise interference radiated from the sun
- B. Rotation of the satellite and its antennas
- C. Doppler shift of the received signal
- D. Interfering signals within the satellite uplink band

T8B11

What is a commonly used method of sending signals to and from a digital satellite?

- A. USB AFSK
- B. PSK31
- C. FM Packet
- D. WSJT

T8D04

What type of transmission is indicated by the term NTSC?

- A. A Normal Transmission mode in Static Circuit
- B. A special mode for earth satellite uplink
- C. An analog fast scan color TV signal
- D. A frame compression scheme for TV signals

T1A07 [97.3(a)(46)]

What is the FCC Part 97 definition of telemetry?

- A. An information bulletin issued by the FCC
- B. A one-way transmission to initiate, modify or terminate functions of a device at a distance
- C. A one-way transmission of measurements at a distance from the measuring instrument
- D. An information bulletin from a VEC

T1A13 [97.3(a)(45)]

What is the FCC Part 97 definition of telecommand?

- A. An instruction bulletin issued by the FCC
- B. A one-way radio transmission of measurements at a distance from the measuring instrument
- C. A one-way transmission to initiate, modify or terminate functions of a device at a distance
- D. An instruction from a VEC

T8C07 [97.215(c)]

What is the maximum power allowed when transmitting telecommand signals to radio controlled models?

- A. 500 milliwatts
- B. 1 watt
- C. 25 watts
- D. 1500 watts

T8C08 [97.215(a)]

What is required in place of on-air station identification when sending signals to a radio control model using amateur frequencies?

- A. Voice identification must be transmitted every 10 minutes
- B. Morse code ID must be sent once per hour
- C. A label indicating the licensee's name, call sign and address must be affixed to the transmitter
- D. A flag must be affixed to the transmitter antenna with the station call sign in 1 inch high letters or larger

T1A03

Which part of the FCC regulations contains the rules governing the Amateur Radio Service?

- A. Part 73
- B. Part 95
- C. Part 90
- D. Part 97

T1A01 [97.1]

Which of the following is a purpose of the Amateur Radio Service as stated in the FCC rules and regulations?

- A. Providing personal radio communications for as many citizens as possible
- B. Providing communications for international non-profit organizations
- C. Advancing skills in the technical and communication phases of the radio art
- D. All of these choices are correct

T1A02 [97.1]

Which agency regulates and enforces the rules for the Amateur Radio Service in the United States?

- A. FEMA
- B. The ITU
- C. The FCC
- D. Homeland Security

T1A05 [97.1 (e)]

Which of the following is a purpose of the Amateur Radio Service rules and regulations as defined by the FCC?

- A. Enhancing international goodwill
- B. Providing inexpensive communication for local emergency organizations
- C. Training of operators in military radio operating procedures
- D. All of these choices are correct

T1A12

Which of the following is a permissible use of the Amateur Radio Service?

- A. Broadcasting music and videos to friends
- B. Providing a way for amateur radio operators to earn additional income by using their stations to pass messages
- C. Providing low-cost communications for start-up businesses
- D. Allowing a person to conduct radio experiments and to communicate with other licensed hams around the world

T1A10 [97.3(a)(5)]

What is the FCC Part 97 definition of an amateur station?

- A. A station in the Amateur Radio Service consisting of the apparatus necessary for carrying on radio communications
- B. A building where Amateur Radio receivers, transmitters, and RF power amplifiers are installed
- C. Any radio station operated by a non-professional
- D. Any radio station for hobby use

T1C13 [97.9(a), 97.17(a)]

For which license classes are new licenses currently available from the FCC?

- A. Novice, Technician, General, Advanced
- B. Technician, Technician Plus, General, Advanced
- C. Novice, Technician Plus, General, Advanced
- D. Technician, General, Amateur Extra

T1C10 [97.5(a)]

How soon after passing the examination for your first amateur radio license may you operate a transmitter on an amateur service frequency?

- A. Immediately
- B. 30 days after the test date
- C. As soon as your operator/station license grant appears in the FCC's license database
- D. You must wait until you receive your license in the mail from the FCC

T1C08 [97.25]

What is the normal term for an FCC-issued primary station/operator amateur radio license grant?

- A. Five years
- B. Life
- C. Ten years
- D. Twenty years

T1C09 [97.21(a)(b)]

What is the grace period following the expiration of an amateur license within which the license may be renewed?

- A. Two years
- B. Three years
- C. Five years
- D. Ten years

T1C11 [97.21(b)]

If your license has expired and is still within the allowable grace period, may you continue to operate a transmitter on amateur service frequencies?

- A. No, transmitting is not allowed until the FCC license database shows that the license has been renewed
- B. Yes, but only if you identify using the suffix GP
- C. Yes, but only during authorized nets
- D. Yes, for up to two years

T1C07 [97.23]

What may result when correspondence from the FCC is returned as undeliverable because the grantee failed to provide the correct mailing address?

- A. Fine or imprisonment
- B. Revocation of the station license or suspension of the operator license
- C. Require the licensee to be re-examined
- D. A reduction of one rank in operator class

T1F13 [97.103(c)]

When must the station licensee make the station and its records available for FCC inspection?

- A. At any time ten days after notification by the FCC of such an inspection
- B. At any time upon request by an FCC representative
- C. Only after failing to comply with an FCC notice of violation
- D. Only when presented with a valid warrant by an FCC official or government agent

T1B03 [97.301(a)]

Which frequency is within the 6 meter band?

- A. 49.00 MHz
- B. 52.525 MHz
- C. 28.50 MHz
- D. 222.15 MHz

T1B04 [97.301(a)]

Which amateur band are you using when your station is transmitting on 146.52 MHz?

- A. 2 meter band
- B. 20 meter band
- C. 14 meter band
- D. 6 meter band

T1B05 [97.301(a)]

Which 70 cm frequency is authorized to a Technician Class license holder operating in ITU Region 2?

- A. 53.350 MHz
- B. 146.520 MHz
- C. 443.350 MHz
- D. 222.520 MHz

T1B06 [97.301(a)]

Which 23 cm frequency is authorized to a Technician Class licensee?

- A. 2315 MHz
- B. 1296 MHz
- C. 3390 MHz
- D. 146.52 MHz

T1B07 [97.301(a)]

What amateur band are you using if you are transmitting on 223.50 MHz?

- A. 15 meter band
- B. 10 meter band
- C. 2 meter band
- D. 1.25 meter band

T1B10 [97.301(e), 97.305(c)]

Which of the bands above 30 MHz that are available to Technician Class operators have mode-restricted sub-bands?

- A. The 6 meter, 2 meter, and 70 cm bands
- B. The 2 meter and 13 cm bands
- C. The 6 meter, 2 meter, and 1.25 meter bands
- D. The 2 meter and 70 cm bands

T1B11 [97.301(a), 97.305 (a)(c)]

What emission modes are permitted in the mode-restricted sub-bands at 50.0 to 50.1 MHz and 144.0 to 144.1 MHz?

- A. CW only
- B. CW and RTTY
- C. SSB only
- D. CW and SSB

T1B13 [97.305(c)]

Which emission may be used between 219 and 220 MHz?

- A. Spread spectrum
- B. Data
- C. SSB voice
- D. Fast-scan television

T1B08 [97.303]

Which of the following is a result of the fact that the amateur service is secondary in some portions of the 70 cm band?

- A. U.S. amateurs may find non-amateur stations in the bands, and must avoid interfering with them
- B. U.S. amateurs must give foreign amateur stations priority in those portions
- C. International communications are not permitted on 70 cm
- D. Digital transmissions are not permitted on 70 cm

T2A11 [97.313(a)]

Which of the following is an FCC rule regarding power levels used in the amateur bands, under normal, non-distress circumstances?

- A. There is no limit to power as long as there is no interference with other services
- B. No more than 200 watts PEP may be used
- C. Up to 1500 watts PEP may be used on any amateur frequency without restriction
- D. While not exceeding the maximum power permitted on a given band, use the minimum power necessary to carry out the desired communication

T1A08 [97.3(a)(22)]

Which of the following entities recommends transmit/receive channels and other parameters for auxiliary and repeater stations?

- A. Frequency Spectrum Manager
- B. Frequency Coordinator
- C. FCC Regional Field Office
- D. International Telecommunications Union

T1A14 [97.303(d)]

What must you do if you are operating on the 23 cm band and learn that you are interfering with a radiolocation station outside the United States?

- A. Stop operating or take steps to eliminate the harmful interference
- B. Nothing, because this band is allocated exclusively to the amateur service
- C. Establish contact with the radiolocation station and ask them to change frequency
- D. Change to CW mode, because this would not likely cause interference

T2A10

What is a band plan, beyond the privileges established by the FCC?

- A. A voluntary guideline for using different modes or activities within an amateur band
- B. A mandated list of operating schedules
- C. A list of scheduled net frequencies
- D. A plan devised by a club to indicate frequency band usage

T1A09 [97.3(a)(22)]

Who selects a Frequency Coordinator?

- A. The FCC Office of Spectrum Management and Coordination Policy
- B. The local chapter of the Office of National Council of Independent Frequency Coordinators
- C. Amateur operators in a local or regional area whose stations are eligible to be auxiliary or repeater stations
- D. FCC Regional Field Office

T1B01

What is the ITU?

- A. An agency of the United States Department of Telecommunications Management
- B. A United Nations agency for information and communication technology issues
- C. An independent frequency coordination agency
- D. A department of the FCC

T1B02 [97.301]

Why are the frequency assignments for some U.S. Territories different from those in the 50 U.S. States?

- A. Some U. S. Territories are located in ITU regions other than region 2
- B. Territorial governments are allowed to select their own frequency allocations
- C. Territorial frequency allocations must also include those of adjacent countries
- D. Any territory that was in existence before the ratification of the Communications Act of 1934 is exempt from FCC frequency regulations

T1B12 [97.301]

Why are frequency assignments for U.S. stations operating maritime mobile not the same everywhere in the world?

- A. Amateur maritime mobile stations in international waters must conform to the frequency assignments of the country nearest to their vessel
- B. Amateur frequency assignments can vary among the three ITU regions
- C. Frequency assignments are determined by the captain of the vessel
- D. Amateur frequency assignments are different in each of the 90 ITU zones

T1C04 [97.107]

When are you allowed to operate your amateur station in a foreign country?

- A. When the foreign country authorizes it
- B. When there is a mutual agreement allowing third party communications
- C. When authorization permits amateur communications in a foreign language
- D. When you are communicating with non-licensed individuals in another country

T1C06 [97.5(a)(2)]

From which of the following locations may an FCC-licensed amateur station transmit, in addition to places where the FCC regulates communications?

- A. From within any country that belongs to the International Telecommunications Union
- B. From within any country that is a member of the United Nations
- C. From anywhere within in ITU Regions 2 and 3
- D. From any vessel or craft located in international waters and documented or registered in the United States

T1C03 [97.117]

What types of international communications are permitted by an FCC-licensed amateur station?

- A. Communications incidental to the purposes of the amateur service and remarks of a personal character
- B. Communications incidental to conducting business or remarks of a personal nature
- C. Only communications incidental to contest exchanges, all other communications are prohibited
- D. Any communications that would be permitted by an international broadcast station

T1D01 [97.111(a)(1)]

With which countries are FCC-licensed amateur stations prohibited from exchanging communications?

- A. Any country whose administration has notified the ITU that it objects to such communications
- B. Any country whose administration has notified the ARRL that it objects to such communications
- C. Any country engaged in hostilities with another country
- D. Any country in violation of the War Powers Act of 1934

T1C02

Which of the following is a valid US amateur radio station call sign?

- A. KMA3505
- B. W3ABC
- C. KDKA
- D. 11Q1176

T1C01 [97.3(a)(11)(iii)]

Which type of call sign has a single letter in both its prefix and suffix?

- A. Vanity
- B. Sequential
- C. Special event
- D. In-memoriam

T1C05

Which of the following is a vanity call sign which a technician class amateur operator might select if available?

- A. K1XXX
- B. KA1X
- C. W1XX
- D. All of these choices are correct

T1C12 [97.19]

Who may select a desired call sign under the vanity call sign rules?

- A. Only licensed amateurs with general or extra class licenses
- B. Only licensed amateurs with an extra class license
- C. Only an amateur licensee who has been licensed continuously for more than 10 years
- D. Any licensed amateur

T1C14 [97.21(a)(1)]

Who may select a vanity call sign for a club station?

- A. Any Extra Class member of the club
- B. Any member of the club
- C. Any officer of the club
- D. Only the person named as trustee on the club station license grant

T1F12 [97.5(b)(2)]

How many persons are required to be members of a club for a club station license to be issued by the FCC?

- A. At least 5
- B. At least 4
- C. A trustee and 2 officers
- D. At least 2

Figure T-1

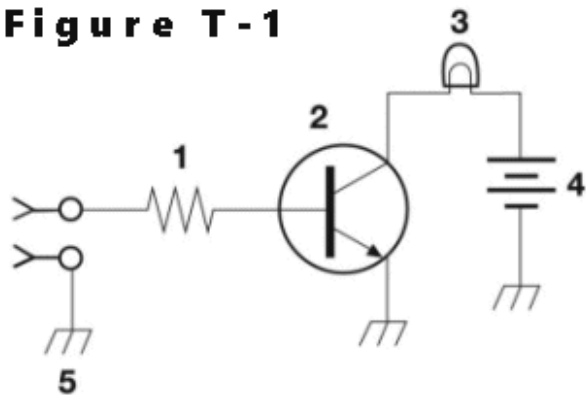

Figure T-2

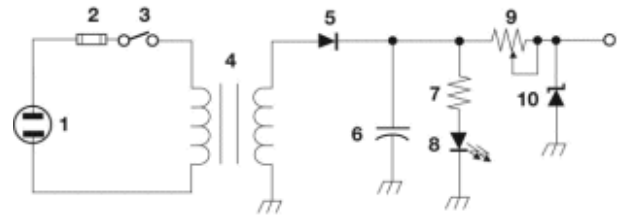

Figure T-3

